

**GENESIS**<sup>®</sup>

The Promise of Performance.

# GRP 480 Rebar Processor

## SAFETY & OPERATOR'S MANUAL



## CONTACT INFORMATION

### Genesis Attachments

1000 Genesis Drive  
Superior, WI 54880 USA

Toll Free: 888-SHEAR-IT  
(888-743-2748)

Phone: 715.395.5252

E-mail:  
info@genesisattachments.com

### Europe/Africa/Middle East Genesis GmbH

Teramostrasse 23  
87700 Memmingen, Germany

Phone: +49 83 31 9 25 98 0  
Fax: +49 83 31 9 25 98 80  
genesis-europe.com

E-mail:  
info@genesis-europe.com

### Asia Pacific Representative Office

24 Upper Serangoon View #12-28  
Singapore 534205

Phone: +65 9673 9730

E-mail:  
tchoo@genesisattachments.com

### Central America & Colombia

Cra 13A #89-38 / Ofi 613  
Bogota, Colombia

Phone: +57 1 610 8160 / 795 8747

E-mail:  
contact@themsagroup.com

View and download all manuals: [genesisattachments.com/manuals](http://genesisattachments.com/manuals)  
Patents: [genesisattachments.com/products/patents](http://genesisattachments.com/products/patents)

## PREFACE

To ensure years of safe, dependable service, only trained and authorized persons should operate and service your Genesis attachment. It is the responsibility of the product's owner to ensure the operator is trained in the safe operation of the product and has available this manual for review. It is the responsibility of the operator and maintenance personnel to read, fully understand and follow all operational and safety-related instructions in this manual. The attachment should not be operated until you have read and fully understand these instructions. Always use good safety practices to protect yourself and those around you.

### **Important**

This operator's manual must accompany the attachment at all times and be readily available to the operator.

### **Manual Replacement**

Should this manual become damaged or lost or if additional copies are required, immediately contact any authorized Genesis dealer or the Genesis Service Department at 888-743-2748 or 715-395-5252 for a replacement. Manuals can also be viewed and downloaded at [genesisattachments.com/manuals](http://genesisattachments.com/manuals).

### **Registration Form**

The Warranty Registration Form must be filled out by the dealer or customer and returned to Genesis indicating the date the attachment went into service.

### **Possible Variations**

Genesis cannot anticipate every possible circumstance that might involve a potential hazard as the owner's requirements and equipment may vary. Therefore, the warnings in this publication and on the product may not be all-inclusive, and you must satisfy yourself that the procedure, application, work method or operating technique is safe for you and others before operating.

### **Public Notice**

Genesis reserves the right to make changes and improvements to its products and technical literature at any time without public notice or obligation. Genesis also reserves the right to discontinue manufacturing any product at its discretion at any time.

### **Warranty**

All work or repairs to be considered for warranty reimbursement must be pre-authorized by the Genesis Service Department. Any alterations, modifications or repairs performed before authorization by the Genesis Service Department will render all warranty reimbursement consideration null and void without exception. See page 59 for Warranty Claim Procedures.

Improper operation or improperly performed maintenance may render any warranty null and void.

# TABLE OF CONTENTS

|  |           |
|--|-----------|
| <b>CONTACT INFORMATION</b> .....                                   | <b>2</b>  |
| <b>PREFACE</b> .....   | <b>3</b>  |
| Important.....   | 3         |
| Manual Replacement.....  | 3         |
| Registration Form.....   | 3         |
| Possible Variations.....   | 3         |
| Public Notice.....   | 3         |
| Warranty.....  | 3         |
| <b>SAFETY STATEMENTS</b> .....                                     | <b>7</b>  |
| <b>OPERATIONAL SAFETY</b> .....                                    | <b>8</b>  |
| Read Manual Before Operating or Maintaining the Attachment.....    | 8         |
| Personal Protection.....   | 8         |
| Know Your Equipment.....   | 8         |
| Before Operating.....  | 8         |
| Check the Equipment.....   | 9         |
| Stability.....   | 9         |
| Know the Work Area.....  | 10        |
| Starting Procedure.....  | 10        |
| Place the Load Safely.....   | 10        |
| Safely Operate Equipment.....                                      | 11        |
| Transporting the Attachment.....                                   | 12        |
| Equipment Condition.....   | 12        |
| Working Overhead.....  | 12        |
| Power Lines.....   | 12        |
| Use Care with Hydraulic Fluid Pressure.....                        | 13        |
| Prioritized Oil Flow.....  | 14        |
| Emergency Situations.....  | 14        |
| Unsafe Conditions.....   | 14        |
| Crystalline Silica Dust.....                                       | 14        |
| Prop. 65 Warning for California Residents.....                     | 14        |
| Process Material Safely.....                                       | 15        |
| Lift the Load Safely.....  | 15        |
| Place the Load Safely.....   | 15        |
| <b>SHEAR NOMENCLATURE</b> .....                                    | <b>16</b> |
| <b>ROTATION LOCK</b> .....   | <b>18</b> |
| <b>SHEAR INSTALLATION</b> .....                                    | <b>19</b> |
| Dual-Pump Flow.....  | 19        |
| <b>ROTATOR INSTALLATION</b> .....                                  | <b>21</b> |
| GRP 480 Rotation Motor.....  | 21        |
| Rotation Circuit - Auxiliary / Rotation Valve / Gerotor Motor..... | 22        |
| Rotation Circuit - Gear Pump / Rotation Valve / Gerotor Motor..... | 23        |
| <b>HYDRAULIC START-UP</b> .....                                    | <b>24</b> |
| Start-up Procedure.....  | 24        |

# TABLE OF CONTENTS

|  |           |
|--|-----------|
| <b>GENERAL OPERATION INSTRUCTIONS</b> .....              | <b>25</b> |
| Start-up .....   | 25        |
| Efficient and Productive Operation .....                 | 25        |
| Cutting Larger Materials .....                           | 26        |
| Chatter While Cutting .....                              | 26        |
| Pulling / Back-Tracking .....                            | 27        |
| Pushing / Tracking Forward .....                         | 28        |
| Cutting in a Pile .....                                  | 29        |
| <b>MAINTENANCE SAFETY</b> .....                          | <b>30</b> |
| <b>MAINTENANCE SCHEDULE</b> .....                        | <b>32</b> |
| Scheduled Maintenance .....                              | 32        |
| Four-Hour Checklist .....                                | 33        |
| Eight-Hour Checklist .....                               | 33        |
| <b>LUBRICATION POINTS</b> .....                          | <b>34</b> |
| <b>BOLT TORQUE SPECS</b> .....                           | <b>35</b> |
| <b>BLADE MAINTENANCE</b> .....                           | <b>36</b> |
| <b>AUTOGUIDES</b> .....                                  | <b>37</b> |
| AutoGuide Adjustment Procedure .....                     | 37        |
| <b>UPPER PIERCING BLADES &amp; LOWER JAW TUSKS</b> ..... | <b>38</b> |
| <b>UPPER PIERCING BLADES</b> .....                       | <b>39</b> |
| Replacement .....  | 40        |
| <b>LOWER JAW TUSKS</b> .....                             | <b>41</b> |
| <b>PRIMARY AND SECONDARY BLADES</b> .....                | <b>42</b> |
| Removal .....  | 42        |
| Adjustment Plates .....                                  | 43        |
| Rotation .....   | 43        |
| Blade Gap .....  | 44        |
| Blade Gap Measuring Procedure .....                      | 44        |
| Shimming .....   | 44        |
| <b>GENERAL WELDING GUIDELINES</b> .....                  | <b>45</b> |
| Welding Ground Clamp .....                               | 45        |
| Welding Rules .....                                      | 45        |
| <b>BUILD-UP</b> .....                                    | <b>46</b> |
| <b>HARD-SURFACING</b> .....                              | <b>47</b> |
| <b>HARD-SURFACING PATTERNS</b> .....                     | <b>48</b> |
| <b>HYDRAULIC/ROTATION MAINTENANCE</b> .....              | <b>49</b> |
| Hydraulic Requirements .....                             | 49        |
| Rotation Valve Input .....                               | 49        |
| GenFlow Regeneration Valve .....                         | 50        |
| Regeneration Valve Adjustment .....                      | 50        |
| <b>REGENERATION VALVE ADJUSTMENT</b> .....               | <b>51</b> |
| <b>GENFLOW REGENERATION VALVE - HOW IT WORKS</b> .....   | <b>52</b> |
| <b>GENFLOW REGENERATION VALVE - 240 GPM</b> .....        | <b>53</b> |
| <b>SLEWING RING MAINTENANCE</b> .....                    | <b>54</b> |
| <b>ROTATION WITH CROSSOVER RELIEF VALVE</b> .....        | <b>55</b> |
| Setting the Crossover Reliefs .....                      | 55        |

## TABLE OF CONTENTS

|   |           |
|---|-----------|
| <b>TROUBLE-SHOOTING GUIDE</b> .....           | <b>56</b> |
| <b>WARRANTY</b> .....                         | <b>59</b> |
| Claim Procedure.....                          | 59        |
| Blade Warranty.....                           | 59        |
| <b>PARTS ORDER POLICY AND PROCEDURE</b> ..... | <b>60</b> |
| Parts Orders Should Include.....              | 60        |
| Placing Orders.....                           | 60        |
| Part Numbers.....                             | 60        |
| Shipping.....                                 | 60        |
| Invoices.....                                 | 60        |
| Returns.....                                  | 60        |
| Warranty Returns.....                         | 60        |
| <b>PARTS ORDER FORM</b> .....                 | <b>61</b> |
| <b>CONTACT INFORMATION</b> .....              | <b>62</b> |

### NOTICE

For bolt torque specs, see the Genesis Fastener Manual.  
[genesisattachments.com/manuals](https://genesisattachments.com/manuals)

## SAFETY STATEMENTS



This symbol by itself or used with a safety signal word throughout this manual is used to call attention to instructions involving your personal safety or the safety of others. Failure to follow these instructions can result in injury or death.



This statement is used where serious injury or death will result if the instructions are not followed properly.



This statement is used where serious injury or death could result if the instructions are not followed properly.



This statement is used where minor or moderate injury could result if the instructions are not followed properly.

**NOTICE**

This statement is used where property damage could result if the instructions are not followed properly.

# OPERATIONAL SAFETY

## Read Manual Before Operating or Maintaining the Attachment



Read this manual before attempting to operate the attachment. This operator's manual should be regarded as part of the attachment. For proper installation, operation and maintenance of the attachment, operators and maintenance personnel must read this manual.



## **WARNING**

Serious injury or death could result if appropriate protective clothing and safety devices are not used.

## Personal Protection

Use protective clothing and safety devices appropriate for the working conditions. These may include but are not limited to:

- ✓ Hard hat
- ✓ Safety glasses, goggles or face shield
- ✓ Hearing protection
- ✓ Safety shoes
- ✓ Heavy gloves
- ✓ Reflective clothing
- ✓ Respirator or filter mask



# Safety matters

## Know Your Equipment



Know your attachment's capabilities, dimensions and functions before operating. Inspect your attachment before operating and never operate an attachment that is not in proper working order. Remove and replace any damaged or worn parts.

## Before Operating

- ✓ Warn all others in the area that you are about to start operation.
- ✓ Perform the Check the Equipment steps outlined in this manual.
- ✓ Check underneath and around the machine. Make sure all personnel and equipment are clear from the area of operation and equipment movement. Check clearances in all directions, including overhead.
- ✓ Be properly seated in the operator's seat.
- ✓ Do not attempt to operate until you have read and fully understand this manual and the OEM manual for the carrier.



# OPERATIONAL SAFETY

## Check the Equipment

Before use, check the equipment to ensure it is in good operating condition.

Check the following:

- ✓ Grease fittings. Pump grease at all fitting locations, see page 34.
- ✓ Hydraulic fluid level. Add hydraulic fluid as required.
- ✓ Hydraulic hoses and hose connections for wear or leaks. Repair or replace any damaged hoses or connections.
- ✓ All control levers for proper operation.
- ✓ Rotation bearing. Visually check for loose or damaged bolts. If repair is required, refer to qualified personnel.
- ✓ Grease rotation bearing and pinion gear.
- ✓ Check for loose or missing pin retaining bolts.
- ✓ Check cylinders for dents (barrel) or dings (rod).



**GOOD  
CONDITION**



**WARNING**

Serious injury or death could result if warnings or instructions regarding carrier stability and the work area are not followed properly.

## Stability

Your Genesis attachment is sized for carrier stability. However, improper operation, faulty maintenance or unauthorized modifications may cause instability.

- ✓ Know the working ranges and capacities of the carrier to avoid tipping.
- ✓ Use the recommended carrier counter weight.

The following conditions affect stability:

- Ground conditions
- Grade
- Weight of attachment
- Contents of attachment
- Operator judgement



For greater stability, knuckle the attachment to bring the load closer to the center of rotation (center of gravity) while lifting. Use extra caution during reaching to avoid tipping.

# OPERATIONAL SAFETY

## **Know the Work Area**

Check clearances in the work area. Keep all bystanders at a safe distance. Do not work under obstacles. Always check your location for overhead and buried power lines or other utilities before operation.

Check ground conditions. Avoid unstable or slippery areas. Position the carrier on firm level ground. If level ground is not possible, position the carrier to use the attachment to the front or back of the carrier. Avoid working over the side of the carrier.

To reduce the risk of tipping and slipping, never park on a grade exceeding 10% (one-foot rise over the span of a ten-foot run).

## **Starting Procedure**

Before operating, walk completely around the equipment to make certain no one is under it, on it or close to it. Keep all bystanders at least 75 feet away from the area of operation and equipment movement. Let all other workers and bystanders know you are preparing to start. DO NOT operate until everyone is clear.

Always be properly seated in the operator's seat before operating any carrier controls.

### **To start:**

- ✓ Make sure all controls are in the center (neutral) position.
- ✓ Be properly seated.
- ✓ Slowly operate all functions to check for proper operation and to bleed air from the hydraulic system.

### **To shut down:**

- ✓ Return your Genesis attachment to a rest position on the ground.
- ✓ Shut off the carrier engine.
- ✓ Work controls in all directions to relieve hydraulic pressure, per excavator manufacturer's instructions.



## **WARNING**

Serious injury or death could result if warnings or instructions regarding safe operation are not followed properly.

## **Place the Load Safely**

Do not move the attachment, or anything held in the jaws, over people, equipment or buildings. Do not throw or drop the contents. Operate the controls smoothly and gradually.

# OPERATIONAL SAFETY

## Safely Operate Equipment

Do not operate equipment until you are trained by a qualified operator in its use and capabilities.

See your carrier's manual for these instructions.

- ✓ Operate only from the operator's seat. Check the seat belt daily and replace if frayed or damaged.
- ✓ Do not operate this or any other equipment under the influence of drugs or alcohol. If you are taking prescription medication or over-the-counter drugs ask your medical provider whether you can safely operate equipment.
- ✓ Never leave equipment unattended with the engine running or with the attachment in a raised position. Apply the brakes before exiting the equipment.
- ✓ Do not exceed the lifting capacity of your carrier.
- ✓ Avoid conditions that can lead to tipping. The carrier can tip when operated on hills, ridges, banks and slopes. Avoid operating across a slope which could cause the carrier to overturn.
- ✓ Reduce speed when driving over rough terrain, on a slope, or when turning to avoid overturning the carrier.
- ✓ Never use the attachment as a work platform or personnel carrier.
- ✓ Keep all step plates, grab bars, pedals and controls free of dirt, grease, debris and oil.
- ✓ Never allow anyone to be around the equipment when it is operating.
- ✓ Do not operate poorly maintained or otherwise faulty equipment. Inform the proper authority and DO NOT resume operation until the problem has been fixed.
- ✓ Do not alter or remove any safety features.
- ✓ Know your work site safety rules as well as traffic rules and flow. When in doubt on any safety issue, contact your supervisor or safety coordinator for an explanation.
- ✓ A heavy load can cause equipment instability. Use extreme care during travel. Slow down on turns and watch out for bumps. The equipment may need additional counter-weights to counterbalance the weight of the attachment.



# OPERATIONAL SAFETY

## Transporting the Attachment

- ✓ Travel only with the attachment in a safe transport position to prevent uncontrolled movement. Drive slowly over rough ground and on slopes.
- ✓ When driving on public roads use safety lights, reflectors, Slow Moving Vehicle signs, etc., to prevent accidents. Check local government regulations that may affect you.
- ✓ Do not drive close to ditches, excavations, etc., as cave-in could result.
- ✓ Do not smoke when refueling the prime mover. Allow room in the fuel tank for expansion. Wipe up any spilled fuel. Secure cap tightly when done.

## Equipment Condition

Never operate poorly maintained equipment. When maintenance is required, repair or replace parts immediately.



### WARNING

Serious injury or death could result if warnings or instructions regarding working overhead are not followed properly.

## Working Overhead



Avoid handling material overhead whenever possible. Safety glass and wire mesh cab guarding must be installed to protect the operator from flying debris that may be created during handling. Falling Object Protection Structures, or FOPS, are necessary for any application where material is to be handled overhead.



### DANGER

Serious injury or death will result if warnings or instructions regarding power lines are not followed properly.

## Power Lines

Do not operate the machine near energized power lines. All local, state/provincial and federal regulations must be met before approaching power lines, overhead or underground cables, or power sources of any kind with any part of the carrier or attachment. Always contact the appropriate utility when operating near power lines. The lines should be moved, insulated, disconnected or de-energized and grounded before operating in the area.



Current in high voltage lines may arc some distance from the wire to a nearby ground. Keep all parts of the machine at least 50 feet (16m) away from power lines.

## OPERATIONAL SAFETY



### WARNING

Serious injury or death could result if warnings or instructions regarding hydraulic fluid pressure are not followed properly.

#### Use Care with Hydraulic Fluid Pressure

Hydraulic fluid under pressure can penetrate the skin and cause serious injury or death. Hydraulic leaks under pressure may not be visible.

- ✓ Keep unprotected body parts, such as face, eyes and arms as far away as possible from a suspected leak. Flesh injected with hydraulic fluid may develop gangrene or other permanent injuries.
- ✓ If injured by injected fluid see a doctor immediately.
- ✓ Wear safety glasses and protective clothing and use a piece of cardboard or wood when searching for hydraulic leaks.

**Do Not Use Your Hands!**  
**See illustration below.**

- ✓ Hydraulic oil becomes hot during operation. Do not let hydraulic oil or components contact skin, as it could cause severe burns. Allow hydraulic components to cool before working on them. Use appropriate protective clothing and safety equipment. If burned, seek immediate medical attention.

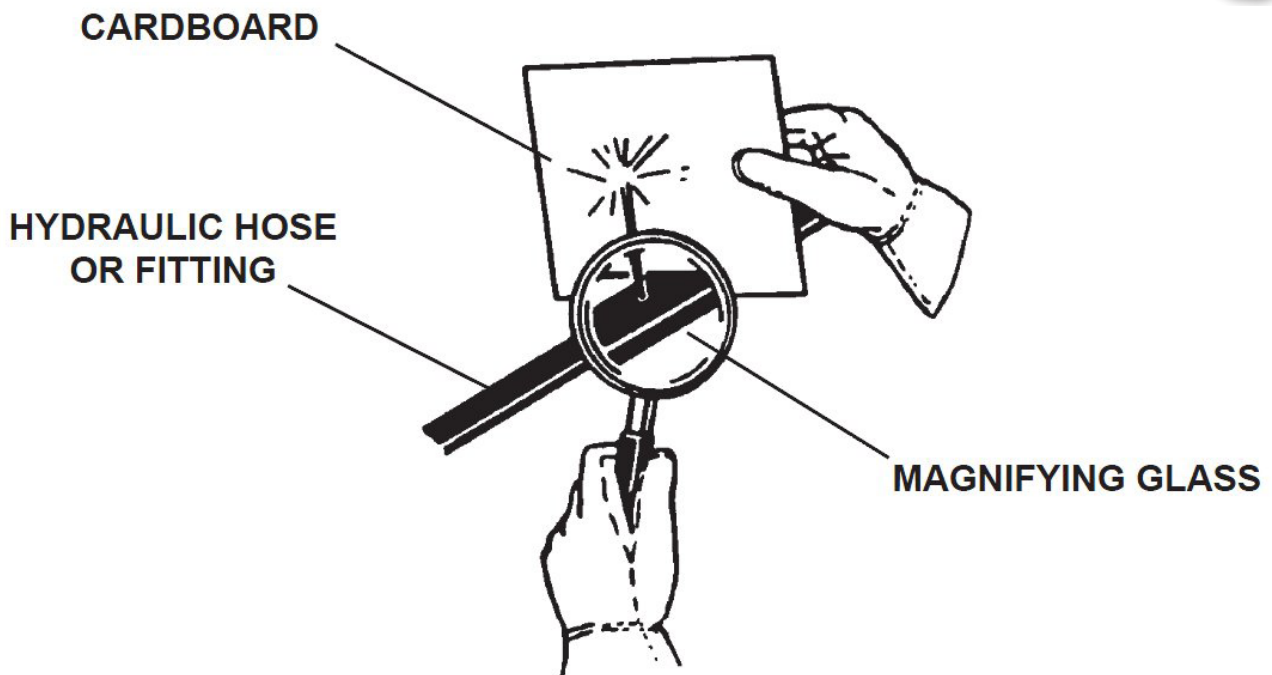

## OPERATIONAL SAFETY

### Prioritized Oil Flow

Equipment operators must ensure there is prioritized oil flow to the main valves in overhead operations or high reach conditions.

### Emergency Situations

Always be prepared for emergencies. Make sure a fire extinguisher is available. Be familiar with its operation. Make sure to inspect and service the fire extinguisher regularly. Make sure a first aid kit is readily available.



### Unsafe Conditions

Do not operate if an unsafe condition exists. Stop operation immediately, shut down the machine and report the unsafe condition to the proper authority. Equipment operation and maintenance practices directly affect your safety and the safety of those around you. Always use common sense while operating and be alert to unsafe conditions.

### Crystalline Silica Dust

It is recommended to use dust suppression, dust collection and if necessary, personal protective equipment during the operation of any attachment that may cause high levels of dust.



**DANGER**

Exposure to respirable crystalline silica dust along with other hazardous dusts may cause serious or fatal respiratory disease.

**IMPORTANT:** Concrete and masonry products contain silica sand. Quartz, which is a form of silica and the most common mineral in the Earth's crust, is associated with many types of rock.

Some activities that may have silica dust present in the air include demolition, sweeping, loading, sawing, hammering, drilling or planing of rock, concrete or masonry.

It is recommended to use dust suppression (such as water) or dust collection (such as a vacuum) along with personal protective equipment if necessary during the operation of any attachment that may cause high levels of silica dust.



### Prop. 65 Warning for California Residents



**WARNING**

This product may contain chemicals known to the State of California to cause cancer, birth defects, or other reproductive harm. For more information visit: [P65Warnings.ca.gov](http://P65Warnings.ca.gov)

## OPERATIONAL SAFETY



### **WARNING**

Using your Genesis attachment in unauthorized applications may create an unsafe situation and will void the warranty.

### **Process Material Safely**

- Do not process hardened steel material such as tool steel, railroad rail, axles, springs, machined parts or high-strength material. Hardened/high-strength material breaks, rather than shears, which may cause flying debris. It will also cause damaging decompression spikes to your Genesis attachment and base carrier hydraulic systems.
- Do not operate any functions of the carrier while cutting or crushing with your attachment, including boom and drive functions.
- Do not pull down structures with your Genesis attachment. Doing so may cause falling debris or material to break free and exceed the capacities of the carrier, causing a tipping hazard and rotation component failures.
- Do not use rotation to pry or break material. Doing so exerts high back-driving forces and spikes to the rotation circuit components that cannot be cushioned hydraulically. It may also cause motor and gearbox failures. The rotator should only be used for positioning an attachment.
- Do not process pressurized containers unless the main valve has been removed and you are absolutely certain the container is empty.
- Do not process spring loaded brake chambers and automotive struts as the release of compressed springs is extremely dangerous. Nothing made of spring material or containing springs should be processed.

### **Lift the Load Safely**

- The hydraulic system has been preset and tested by your dealer. Do not alter hydraulic settings without consulting an authorized Genesis dealer or the Genesis Service Department. Doing so will void the warranty and may cause structural damage, accidents or tipping.
- Make sure the load is held securely in the jaws. Do not move a loaded attachment if load is loose or dangling. Make sure the load is pinched between the jaws – never cradle a load.
- For greater stability, knuckle the attachment to bring the load closer to the center of rotation (center of gravity) while lifting. Use extra caution during reaching to avoid tipping.

### **Place the Load Safely**

- Do not move the attachment, or anything held in the jaws, over people, equipment or buildings. Place the load gently. Do not throw or drop the contents.
- Operate the controls smoothly and gradually. Jerky controls are hazardous and may cause damage to the carrier.
- Avoid fire hazards. Keep the area clean. Remove all flammable materials from the area during any welding or heating process. Have a fire extinguisher nearby and know how to use it.
- Never substitute pins or bolts. Use factory supplied pins. Replace all bolts with the same size and grade. Failure to do so may cause serious injury or death and void the warranty.
- Use your Genesis attachment only as directed in this manual. Do not use the attachment to lift and move other objects. Doing so may cause instability and tipping.

# SHEAR NOMENCLATURE

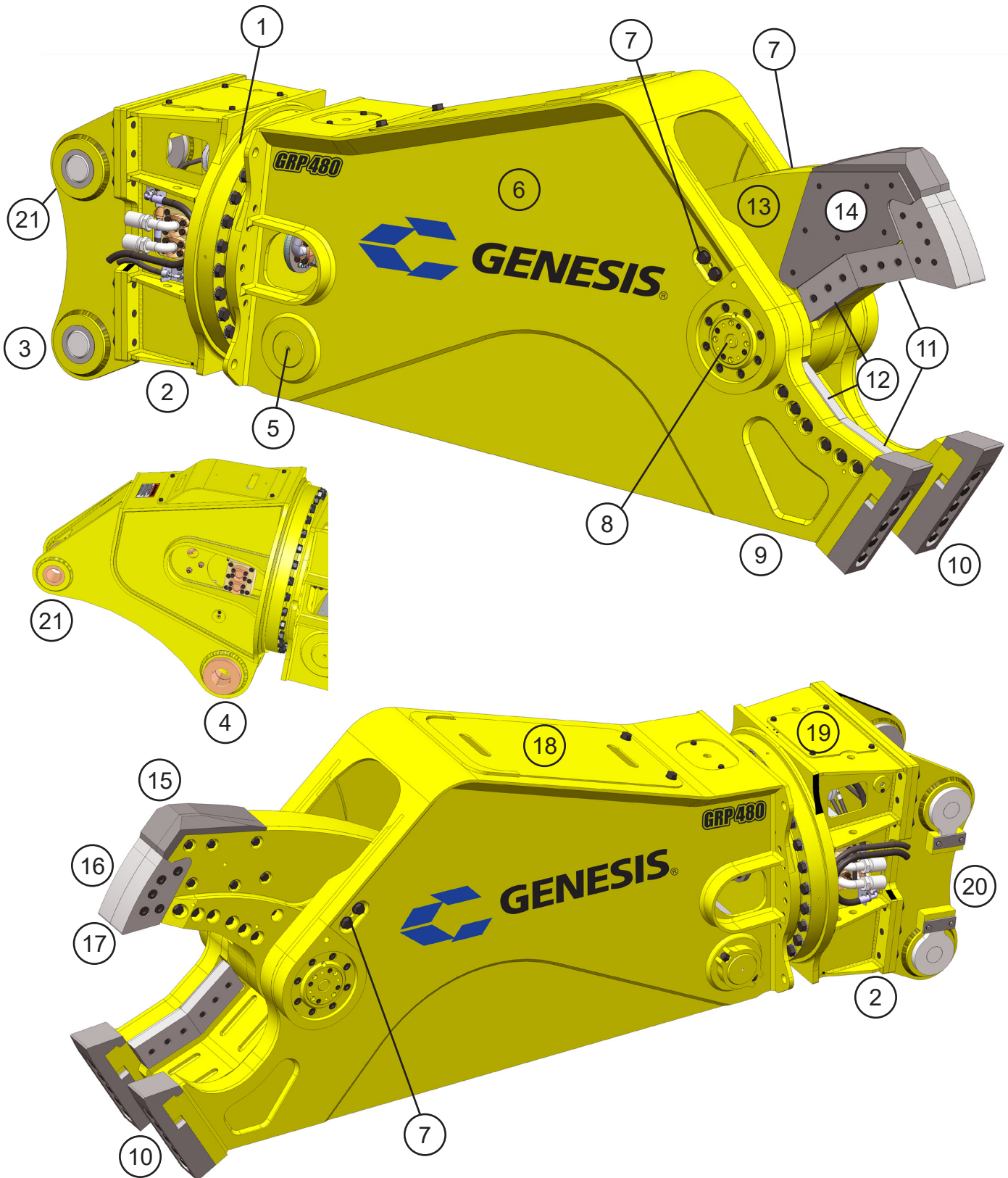



## SHEAR NOMENCLATURE

|    |                              |  |
|----|------------------------------|--|
| 1  | <b>Slewing Ring</b>          | Connects the shear head to the shear stick or body. Not used on straight shears.   |
| 2  | <b>Shear Sub-Head</b>        | Houses and protects the hydraulic components used for 360° rotation.   |
| 3  | <b>Stick Connection</b>      | Connects a third-member shear to the excavator stick.  |
| 4  | <b>Boom Pivot Connection</b> | Connects a second-member shear to the excavator boom.  |
| 5  | <b>Rear Cylinder Pin</b>     | Connects the cylinder to the shear body.   |
| 6  | <b>Shear Stick or Body</b>   | Houses and protects the main hydraulic cylinder.   |
| 7  | <b>AutoGuide or Puck</b>     | Guides the upper jaw into the lower jaw.   |
| 8  | <b>Pivot Group</b>           | The assembly that allows the upper jaw to pivot. Includes the end cap, tie rod and tie rod nut.  |
| 9  | <b>Lower Shear Jaw</b>       | The front of the shear body opposite the upper jaw.  |
| 10 | <b>Lower Jaw Tusks</b>       | Wear parts that help separate rebar bundles.   |
| 11 | <b>Secondary Blades</b>      | The upper and lower cutting blades farthest from the pivot group. Only insert shims behind the lower, placing between the adjustment plate and blade when setting/adjusting blade gap. |
| 12 | <b>Primary Blades</b>        | The upper and lower cutting blades closest to the pivot group. Only insert shims behind the lower, placing between the adjustment plate and blade when setting/adjusting blade gap.    |
| 13 | <b>Upper Shear Jaw</b>       | The moving jaw. Never shim blades in upper jaw.  |
| 14 | <b>Upper Jaw Wear Plate</b>  | Large blade side wear plate.   |
| 15 | <b>Rhino Horn</b>            | The wear part that caps the top front area of the upper jaw.   |
| 16 | <b>Tang</b>                  | Parent material underneath and between the piercing blades   |
| 17 | <b>Piercing Blades</b>       | The jaw blades at the front of the upper jaw. NEVER insert shims behind.   |
| 18 | <b>Access Cover</b>          | Access to hydraulic cylinder and regen block.  |
| 19 | <b>Access Cover</b>          | Access to hydraulic motor, gear box and rotation flow controls.  |
| 20 | <b>Shear Head Lugs</b>       | Shear serial number required for replacement parts.  |
| 21 | <b>Cylinder Connection</b>   | Excavator cylinder connection  |

## ROTATION LOCK

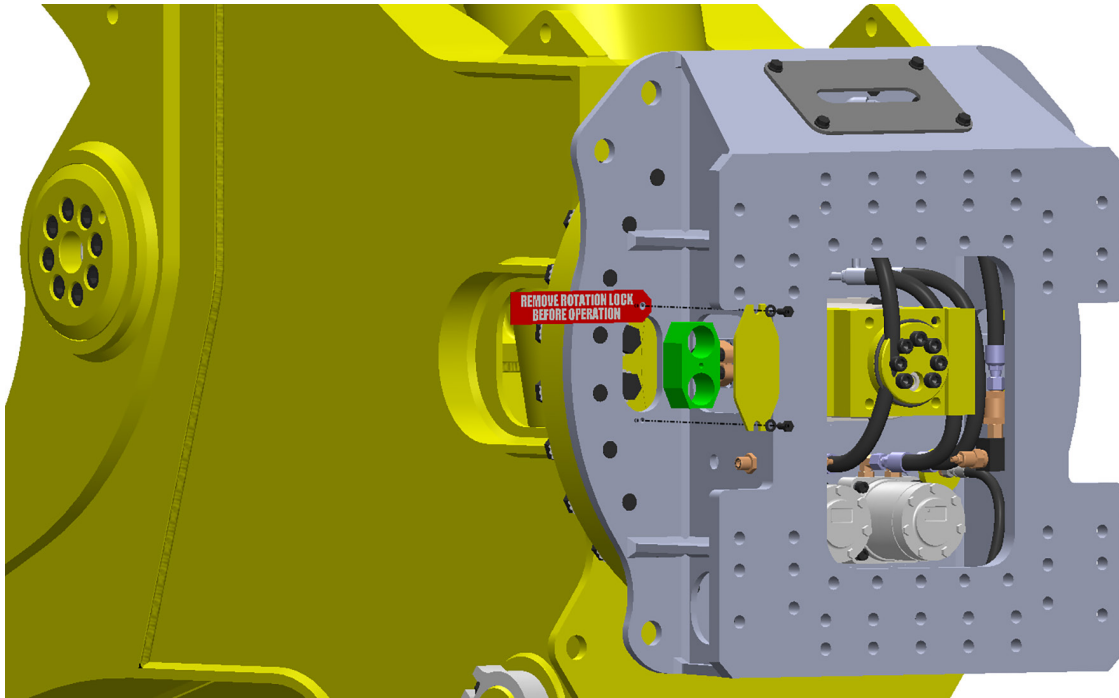

Rotation (transport) locks are installed at the factory to allow the bracket to be shipped with the mounting pins facing upward. This is beneficial to the end user when removing the attachment from the truck and mounting it to the excavator.

**Rotation locks MUST be removed before operating the attachment to prevent rotation system damage.**

The rotation locks are located inside the small bolt covers for the slewing ring and marked with a red flag labeled “REMOVE ROTATION LOCK BEFORE OPERATION”. The cover bolt can be threaded into the rotation lock for removal.

There are TWO locks in every attachment, one on either side of the bracket. In some cases, one of the port blocks may need to be removed to access the rotation lock. The rotation locks and red flags should be saved for use during future transportation.

## SHEAR INSTALLATION

**Preparation of the excavator prior to attachment delivery will make installation safer and easier. Contact Genesis or your Genesis dealer for assistance.**

### **Dual-Pump Flow**

An excavator typically has two hydraulic pumps that supply oil to its main control valve, which is usually separated into two halves. Combining the flow from both halves of the control valve is called summing, thus achieving dual-pump flow to operate one circuit.

Summing is the preferred method of achieving maximum speed to an attachment. However, interchanging the stick and bucket circuits may also substantially increase speed.

A bucket circuit is usually single-pump flow while a stick circuit is dual-pump flow. At times, adding an auxiliary circuit spool to the stick circuit helps reduce back pressure in the system and speed up jaw open and close.

In certain cases, the bucket and auxiliary circuits can be summated to achieve dual-pump flow, depending on whether the bucket and auxiliary are on separate sides of the main valve and whether the auxiliary circuit can be proportionally controlled by teeing into the bucket pilot control circuit.

The auxiliary circuit must also be capable of proportionally controlling pump initiation on the auxiliary side of the circuit. On many excavators, the auxiliary circuit is controlled by the flow percentage set in the operating system. Because attachments take all the flow the pumps can give them, when this percentage is reached, the pump will instantly turn on or off instead of gradually increasing or decreasing, which can cause sharp, damaging spikes in the hydraulic circuit.

If excavator circuits are electronically controlled, it may be necessary to reduce the spool shift and pump initiation in the excavator software to take spiking out of the circuit when changing attachment cylinder direction from full extend or full retract.

On excavators with full hydraulic spool piloting, install a flow control into the pilot lines between the joystick and spools. The flow control can then be adjusted to slow the pilot oil flow to the spool, which in turn slows how the spool shifts and the pumps stroke up.

## SHEAR INSTALLATION



### WARNING

Be sure hydraulic pressure is relieved before disconnecting hydraulic fittings. Remove necessary fittings SLOWLY.

The attachment is usually shipped in an upright position with the mounting pins facing up.

Follow the excavator OEM's removal and safety instructions to remove the bucket or other stick attachments.

Track the excavator to the attachment with the jaws facing the operator. Lift the excavator stick over the attachment, carefully positioning the stick tip connection with the attachment mounting main pivot bore. Pin the excavator stick to the attachment.

Slowly raise the boom to lift the attachment, allowing the cylinder pivot connection to come within range of the excavator cylinder stroke.

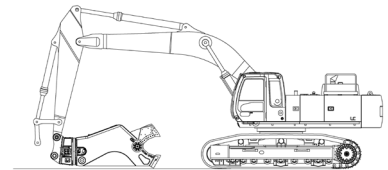

Extend the excavator cylinder until the power link bore lines up with the cylinder pivot connection. Pin the excavator cylinder to the attachment.

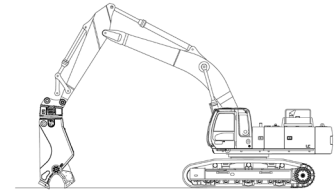

Crowd and extend the attachment, checking closely to make sure there is no interference between the bracket and hard lines. Also check for interference between the cylinder and boom/stick.

Install excavator hydraulic hoses, supply and return, from the stick tip to the attachment manifold blocks.

The stick and bucket circuits are oriented as to rod and bore sides of their respective cylinders. Be sure to connect rod-to-rod and bore-to-bore when connecting a circuit to the attachment. When these are reversed, extra pressure is needed to open the jaw, which pulls down the engine, de-strokes the pumps, increases jaw cycle time, creates high oil temperature and burns more fuel.

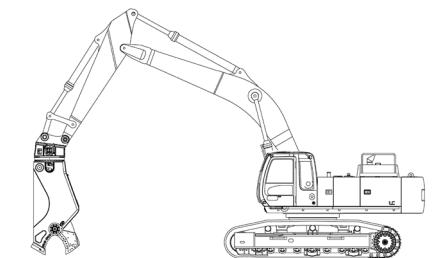

The attachment must be vertical before putting oil into it or an air lock in the regen valve may prevent the jaw from opening.

**Note: Genesis' standard pin material is Induction Hardened Chrome (IHC), which is to be used for all direct pin 2<sup>nd</sup> and 3<sup>rd</sup> member mounting. To avoid risk of pin failure when using a pin grabbing coupler, the standard IHC pins must be replaced with a heat-treated pin material from Genesis.**



### WARNING

Removing any connecting pin may be hazardous. To remove a connecting pin, position the attachment on the ground and properly support. Particles may fly when a pin is struck. Use a drift pin or mallet when striking pins. Keep all personnel at a safe distance.

## ROTATOR INSTALLATION

The rotator requires a 1/2" minimum case-drain line with a minimum working pressure rating of 250 PSI. **Run the case-drain line from the rotation head of the shear to a dedicated filter on the excavator, plumbed directly into the main section of the hydraulic tank. Do not plumb to the return side of the tank.**

The maximum case-drain pressure measured at the motor while attempting to rotate the shear stalled on the ground is 40 PSI for an axial piston motor. Gerotor type motors may or may not require a case drain. If 3 O-ring face seal bulkheads are present on your sub-head, a case drain is required. If you are unsure of your motor type or if a case drain is required, contact the Genesis Parts or Service Departments with the serial number of your shear. Case-drain pressures will rise during cold weather operation.

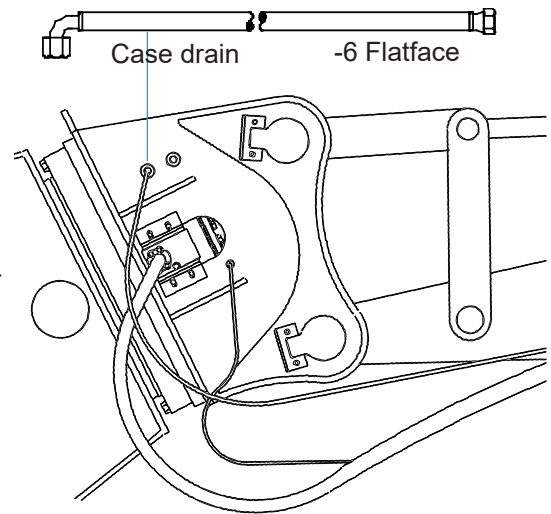

Use the correct fittings. Secure the case-drain line to the excavator stick.

### NOTICE

**Do not plumb the case-drain into the main return system or into any other existing case drain or return circuit. Plumb only to the hydraulic tank.**

### GRP 480 Rotation Motor

The gerotor motor is a direct drive motor.

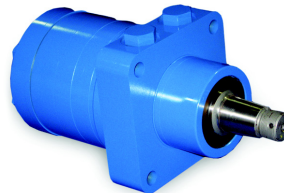

Gerotor Motor

## Rotation Circuit - Auxiliary / Rotation Valve / Gerotor Motor

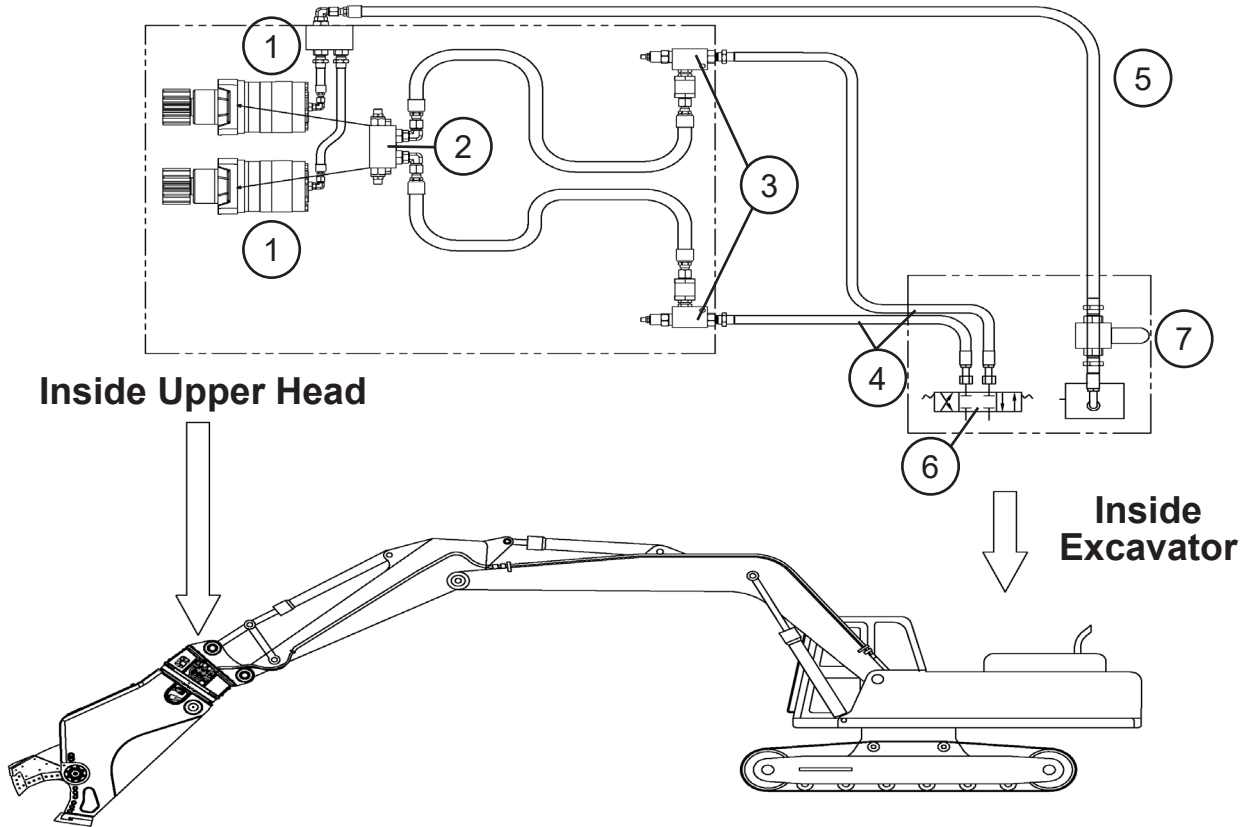

|   |                             |  |
|---|-----------------------------|--|
| 1 | <b>Gerotor Motor</b>        |  |
| 2 | <b>Motion Control Valve</b> |  |
| 3 | <b>Flow Controls</b>        |  |
| 4 | <b>Rotate Work Lines</b>    | Use ½" 3000 PSI rated hoses.   |
| 5 | <b>Case Drain</b>           | Use minimum ½" 2000 PSI rated hose (to return filter).   |
| 6 | <b>Auxiliary Valve</b>      | 3 position, tandem center, spring centered, with anti-cavitation checks. Port relief settings: 2000 PSI. |
| 7 | <b>Dedicated Filter</b>     | Dedicated to case drain only, 10 micron.   |

## Rotation Circuit - Gear Pump / Rotation Valve / Gerotor Motor

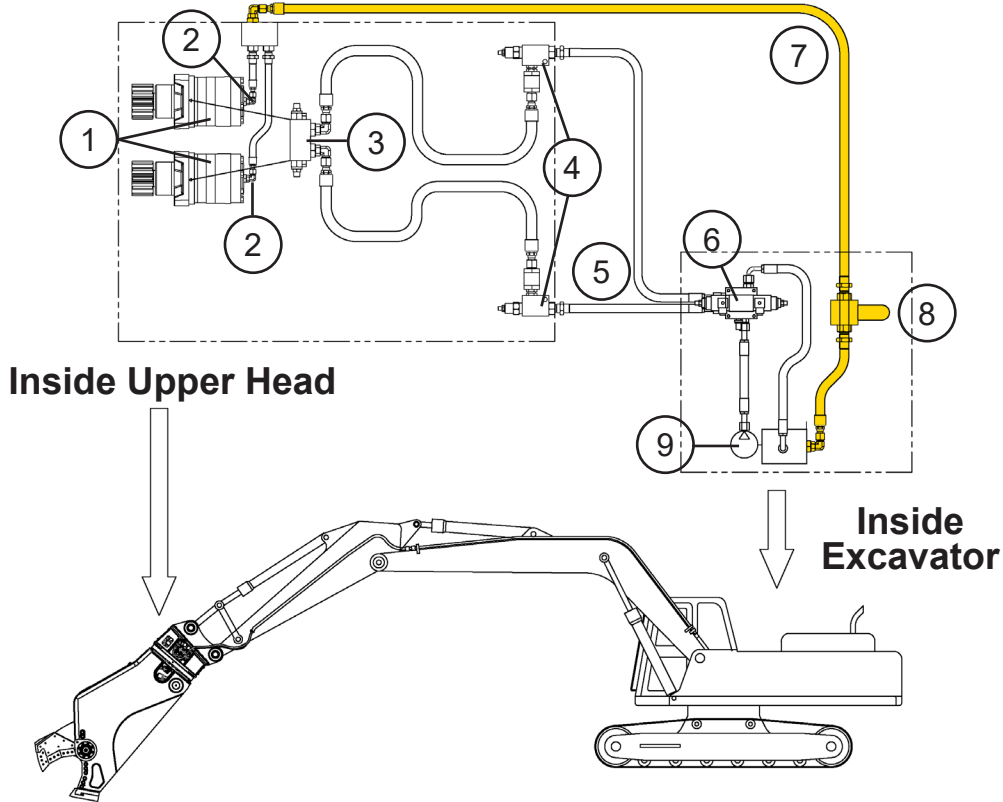

|   |                             |   |
|---|-----------------------------|---|
| 1 | <b>Gerotor Motor</b>        |   |
| 2 | <b>Motor Case Drain</b>     | Do not exceed 40 PSI while operating.   |
| 3 | <b>Motion Control Valve</b> |   |
| 4 | <b>Flow Controls</b>        |   |
| 5 | <b>Rotate Work Lines</b>    | Use ½" 3000 PSI rated hose.   |
| 6 | <b>Rotation Valve</b>       | 3 position, tandem center, spring centered, with anti-cavitation checks. Port relief settings: 2000 PSI.  |
| 7 | <b>Case Drain</b>           | Use minimum ½" 2000 PSI rated hose (to dedicated filter). <b>Do not plumb the case-drain into the main return system or into any other existing case drain or return circuit. Plumb only to the hydraulic tank.</b> |
| 8 | <b>Dedicated Filter</b>     | Dedicated to case drain line only - 10 Micron   |
| 9 | <b>Gear Pump</b>            |   |

## HYDRAULIC START-UP

Genesis shears are designed to operate under full excavator pressure or up to 5500 PSI. Due to these high pressures, it is important that air is bled from the shear cylinder after installation. Failure to follow these procedures could result in cylinder seal damage and/or excavator hydraulic system damage.

### Start-up Procedure

- ✓ Check the excavator hydraulic tank for proper fluid level.
- ✓ Excavator oil should be warmed up before hooking up shear lines in cold weather. If oil is cold, air from the cylinder will be pushed into the oil tank, causing the oil to foam. This problem takes hours to correct and may cause pump cavitation.
- ✓ Follow the OEM procedures for starting and warming the excavator hydraulic system. Do not operate the shear circuit during the warm-up period.
- ✓ After the excavator has reached normal operating temperature, set the engine to idle speed.
- ✓ The shear must be vertical. Do not allow the tank to run low - have someone watch the oil gauge.
- ✓ Slowly fill the bore end of the shear cylinder to partially close the jaws.

## NOTICE

Do not fully extend or retract the shear cylinder with the first cycles.

- ✓ Slowly fill the rod end of the shear cylinder to open the jaws. Use partial strokes extending and retracting, slowly working to full strokes.
- ✓ Stop and check the excavator hydraulic fluid level again to be sure there is still sufficient fluid. Service as required. The hydraulic fluid level should be checked with the shear jaws open (cylinder retracted).
- ✓ Cycle the shear jaws five or six strokes before increasing to full operating pressure.



## GENERAL OPERATION INSTRUCTIONS

Follow all rules and procedures outlined in the Operation Safety section of this manual.

Use the shear only as intended, in approved applications, as set forth in this manual.

Do not allow shear, exposed cylinder rod or hoses to come into contact with any obstacles, buildings or the excavator.

The shear is not intended to crush or break objects or structures by swinging or dropping the shear.

### **Start-up**

During initial operation and any time jaw maintenance has been performed, process thin and lighter material first to work-harden wear areas, developing a harder, more durable edge. This is also the most effective time to process materials such as wire mesh. The new or repaired edges will cut more efficiently and be less likely to jam material between the blades.

### **NOTICE**

When operating in temperatures below freezing, it is also important to process light materials first. This allows the shear's structural material to "warm up," preventing thermal cracking.

### **Efficient and Productive Operation**

Operators should become accustomed to performing work in the most proficient manner possible.

When cutting, use the upper and lower tips to separate rebar bundles, keeping the surfaces of the lower and upper jaws out of the dirt as much as possible. Dirt is much more abrasive than steel and needlessly increases build-up and hard-surfacing time and intervals.

It also helps to give yourself enough room to keep out of the way of other personnel and machines. Material should be picked from a pile and swung to the side and cut in a new area. This prevents redundant cutting of the same pieces and allows for the newly prepared material to be loaded out with another material handling machine.

Material processing areas should be as close as safely possible to the location for loading materials for transportation. Less time spent processing, loading and transporting materials greatly affects operational costs and productivity and dramatically reduces man hours, fuel costs and wear on equipment.

Operators should develop the habit of assessing materials to be processed and visualizing a starting and finishing point to use the fewest cuts possible. Excessive moving, positioning and handling cost time and money. Bringing the jaws to full open, when only partial jaw open is needed for a cut, wastes time and fuel, slows other excavator functions as well as causes needless wear to hydraulic components, hoses and o-rings. More efficient processing will extend the life of the attachment.

## GENERAL OPERATION INSTRUCTIONS

### **Cutting Larger Materials**

The operator will need to get a feel for the size and amount of rebar the GRP 480 can cut. Trying to cut too much material in one bite can be less productive if the shear bogs down and cuts slowly. This will generally increase the amount of stress in the jaw and shorten the life of the tool from fatigue.

Segregating strands of rebar in the jaw, versus bunching it up, enables the shear to cut more easily.

Suspend the material on the prepared pile, open the jaw and position the material as close to the throat as possible. Without pushing down on the material with excavator force, rapidly close the jaw on the material. Using the speed of regeneration can improve performance when cutting larger materials.

### **Chatter While Cutting**

If the shear starts to chatter while cutting, back out of the cut and reposition the rebar to a different area of the jaw.

Chattering is an indication that material is jamming between the upper and lower cutting blades. This indicates that blade maintenance needs to be performed immediately. Worn blades and improper blade gaps are usually the cause.

Most jamming conditions can be prevented if the operator pays attention to the sound and vibration that is associated with a jam. Remember that because of the rod-to-bore ratios of displacement on the shear's hydraulic cylinder piston, the shear has half the force on jaw open compared to jaw close. So if the attachment is jamming while closing, it may not have enough retract force to open.

# GENERAL OPERATION INSTRUCTIONS

## Pulling / Back-Tracking

It may, at times, be necessary to pull material from a pile or better position pieces to be cut.

To minimize stress in the shear body and damage to the pivot components, it is best to keep the shear in line with the boom and stick.

If the shear needs to be perpendicular to the boom and stick, the blade side of the shear should face **TOWARD** the operator.

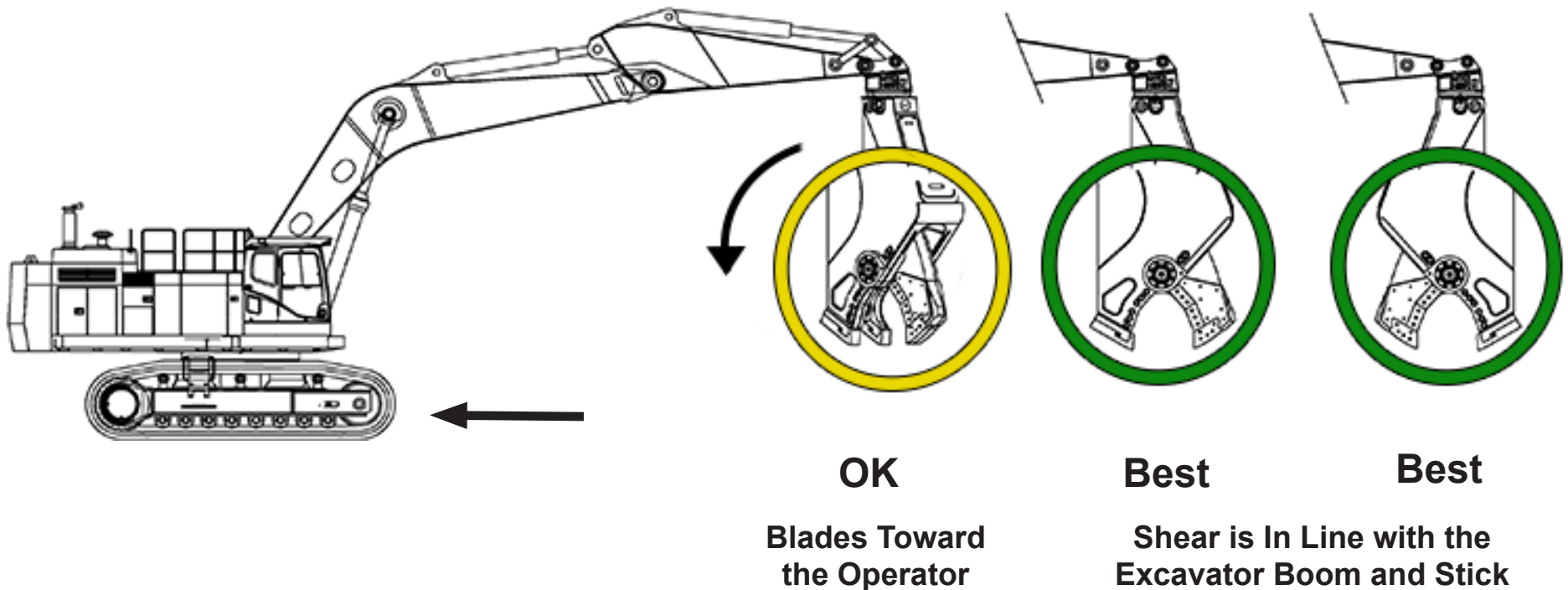

# GENERAL OPERATION INSTRUCTIONS

## Pushing / Tracking Forward

When pushing material, it is best to keep the shear in line with the boom and stick.

If the shear needs to be perpendicular to the boom and stick, the blade side of the shear should face **AWAY** from the operator.

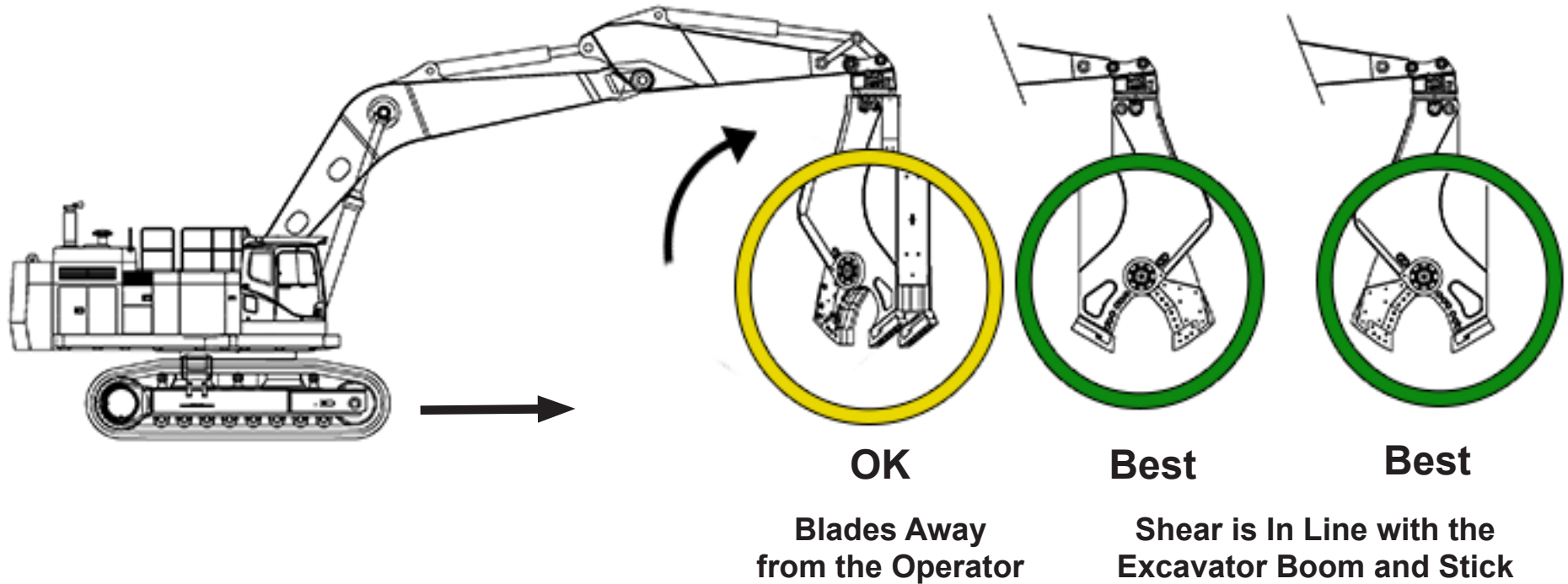

## GENERAL OPERATION INSTRUCTIONS

### Cutting in a Pile

Material that is stacked in a pile has a resistance to movement that causes undo stress in the shear body when you try to cut it. This stress occurs in **both straight and rotating units** because the shear will work to align itself with the material.

It is best to cut material that freely moves so work to free pieces or cut from the top of the pile down.

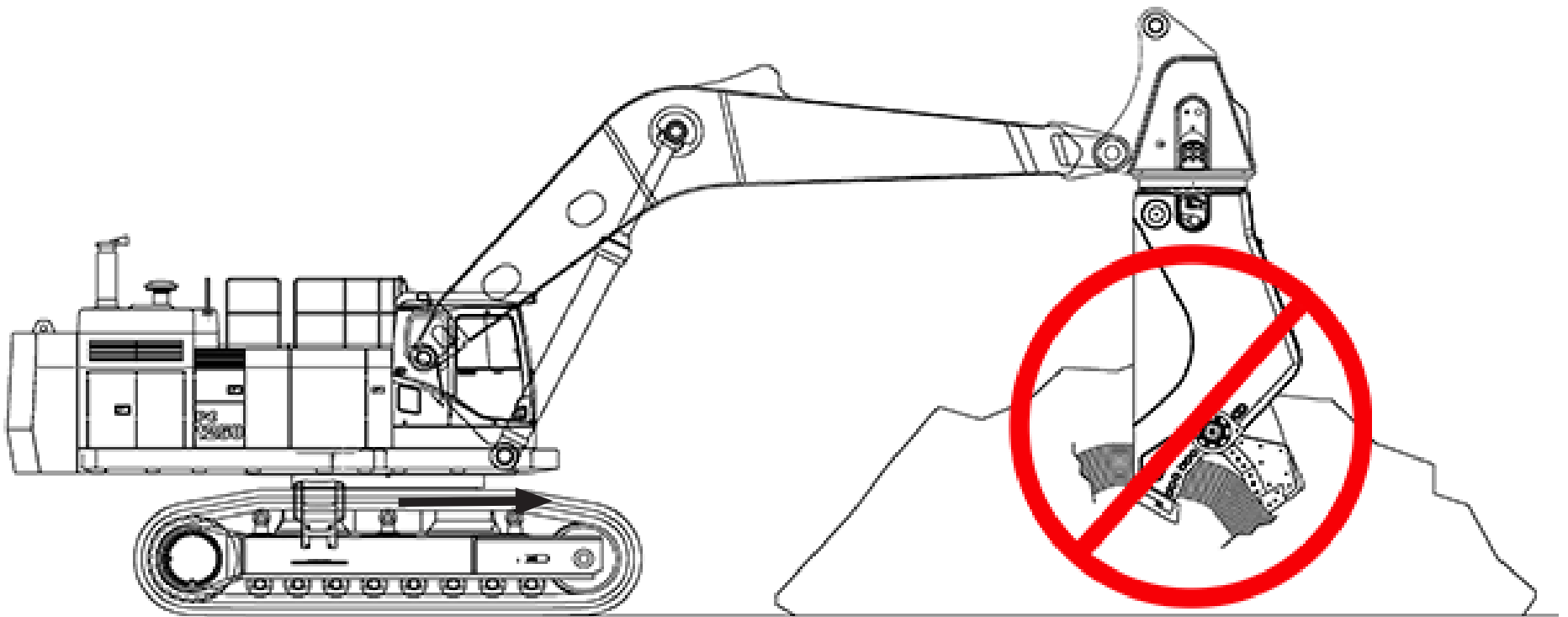

## MAINTENANCE SAFETY

Only trained and authorized persons should perform maintenance on the shear. To be qualified, you must understand the instructions in this manual, have training, and know the safety rules and regulations of the job site.

Do not alter the physical, mechanical or hydraulic operation of the shear. Doing so may cause a dangerous situation for yourself and those around you and will void the warranty.

Do not attempt repairs you do not understand. If any questions arise regarding a safety or maintenance procedure, contact Genesis or your Genesis dealer.

Read this entire manual. All personnel must understand the maintenance and safety procedures.

Use factory authorized parts. The use of unauthorized parts may compromise safety, performance and durability of the shear and may void the warranty.

Follow the daily checklist and maintenance schedules in this manual. Extreme conditions may dictate shorter maintenance intervals.

Do not exceed bolt torque specifications. See the Genesis Fastener Manual.

Do not weld on structural components without consulting Genesis. Doing so may cause structural failure and void the warranty.

Do not operate a shear without the case-drain line properly installed if the shear uses a rotation system that requires a case drain. Doing so will cause immediate failure of the rotate motor and gearbox.

Do not work on the shear before ensuring it will not move. Completely lower the boom to the ground or a rest position and relieve hydraulic pressure.

Never operate poorly maintained equipment. When maintenance is required, repair or replace parts immediately.

Do not operate under unsafe conditions. If an unsafe condition arises during operation, immediately shut down the equipment and report the situation to the proper authority.

## MAINTENANCE SAFETY

Do not work on any hydraulic lines or components while they are pressurized. Escaping hydraulic fluid can penetrate the skin, causing serious injury or death. Relieve pressure before performing maintenance. Keep hands and body parts away from pin holes and nozzles, which eject fluids under high pressure. Use a piece of cardboard to search for leaks.



If fluid is injected into the skin, seek medical assistance immediately from a doctor familiar with this type of injury.

### NOTICE

See "Use Care with Hydraulic Fluid Pressure", page 13

Hydraulic oil becomes hot during operation. Do not let hydraulic oil or components contact skin, as it could cause severe burns. Allow hydraulic components to cool before working on them. Use protective clothing and safety equipment.



Remove paint before welding or heating. Hazardous fumes/dust can be generated when paint is heated by welding, soldering or using a torch. Do all work outside or in a well ventilated area and dispose of paint and solvent properly.

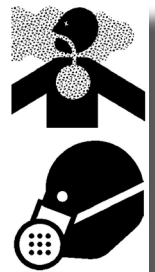

When sanding or grinding paint, avoid breathing the dust. Wear an approved respirator. If you use solvent or paint stripper, remove stripper with soap and water before welding. Remove solvent or paint stripper containers and other flammable materials from area. Allow fumes to disperse at least 15 minutes before welding or heating.

Avoid fire hazards. Keep the area clean. Remove all flammable materials from the area during any welding or heating process. Have a fire extinguisher nearby and know how to use it.



Never substitute pins or bolts. Use factory supplied pins. Replace all bolts with the same size and grade. Failure to do so may cause serious injury or death and void the warranty.

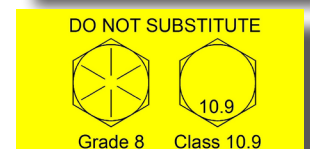

## MAINTENANCE SCHEDULE

Performing scheduled maintenance will promote safe, reliable operation of your shear. Inspect and grease components every eight hours of operation, as indicated on the following checklist. Use maintenance procedures described in this manual. If you are not able to safely and competently perform these procedures, have a Genesis dealer perform them.

After the first **80 hours** of operation, check all bolts, including slewing ring bolts.

### NOTICE

Extreme operating conditions may require shortened maintenance intervals.

Operating the shear with excessively worn blades, blade gaps or main bearings could lead to premature cylinder failure. Excessive deflection of the upper jaw from these conditions will transfer side loading forces to the cylinder piston and barrel, which causes undue pressure on the wear bands of the piston, potentially resulting in cylinder failure.

Pounding the upper jaw lever arm or cylinder clevis on the ground or a hard object to clear a material jam can cause high pressure hydraulic spikes to the shear and excavator which can damage the hydraulic system components. These spikes can damage the cylinder piston seals, which will allow oil to bypass and wash out the piston wear bands, resulting in premature and possibly catastrophic system failures.

### Scheduled Maintenance

- ✓ Check gearbox lube every 125 hours. Change annually.
- ✓ Replace regeneration valve components every 2000 hours.
- ✓ Reseal cylinder at 1 year or 2000 hours, whichever occurs first, the first time; 9 months or 1500 hours for all following reseals. In severe-duty applications or if operating the shear more than 10 hours per day, reduce these intervals.
- ✓ Reseal swivel every year or at the time of cylinder resealing.



# MAINTENANCE SCHEDULE

## **Four-Hour Checklist**

Mid-shift, perform a brief visual check for hydraulic leaks, blade damage, and loose or missing bolts. A more thorough inspection, to be performed at the end of each shift, is described below on the eight-hour checklist.

### **Grease:**

- Shear cylinder - end of pin
- Shear cylinder rod
- AutoGuide at fitting and smear grease on contact surface of upper jaw
- Main shaft/pivot, both sides

Grease all locations until grease extrusion is visible with jaw open and closed.

## **Eight-Hour Checklist**

### **Inspect:**

- Bolts - check for loose bolts, replace if damaged
- Fittings and hoses for damage or leaks
- Bracket pivot for wear and pin retainers
- Cylinder pivot for wear and pin retainers
- Entire shear for cracks (visual check)

### **Grease:**

- Bracket pivot
- Bracket cylinder
- Bearing slewing (four locations)
- All points listed in 4-hour checklist

Grease all locations until grease extrusion is visible.

### **Jaws and Blades:**

- Check blade gaps\*
- Check blade edge radiuses\*
- Check for loose or damaged bolts, re-torquing loose bolts when cool
- Check AutoGuides and shim if needed
- Build-up and hard-surface as required
- Grind off any rolled-over or mushroomed blade edges
- Shear Jaw Armor® - build-up and hard-surface as needed, check for broken weld joints and repair as needed

- \* See Blade Maintenance information in this manual regarding maximum gap and radius for your specific shear model. Blade gaps should be checked and maintenance performed when the shear has cooled to ambient temperature.

# LUBRICATION POINTS



Shut off excavator and disable hydraulics per OEM instructions before greasing.

For normal conditions above 32°F (0°C), use a lithium-based, premium grade 2 extreme-pressure grease. For temperatures below 32°F, use a grade 0 grease.

**Do not use grease containing Molybdenum (Moly).**

Genesis GLG-2® anti-wear, extreme-pressure lithium grease, PN 6302601, is recommended for all temperature conditions.

The shear jaws must be closed for access to all grease fittings. Grease all fittings every four to eight hours of operation (see Maintenance Schedule).

After greasing the rotation bearing, rotate the shear through two full rotations.

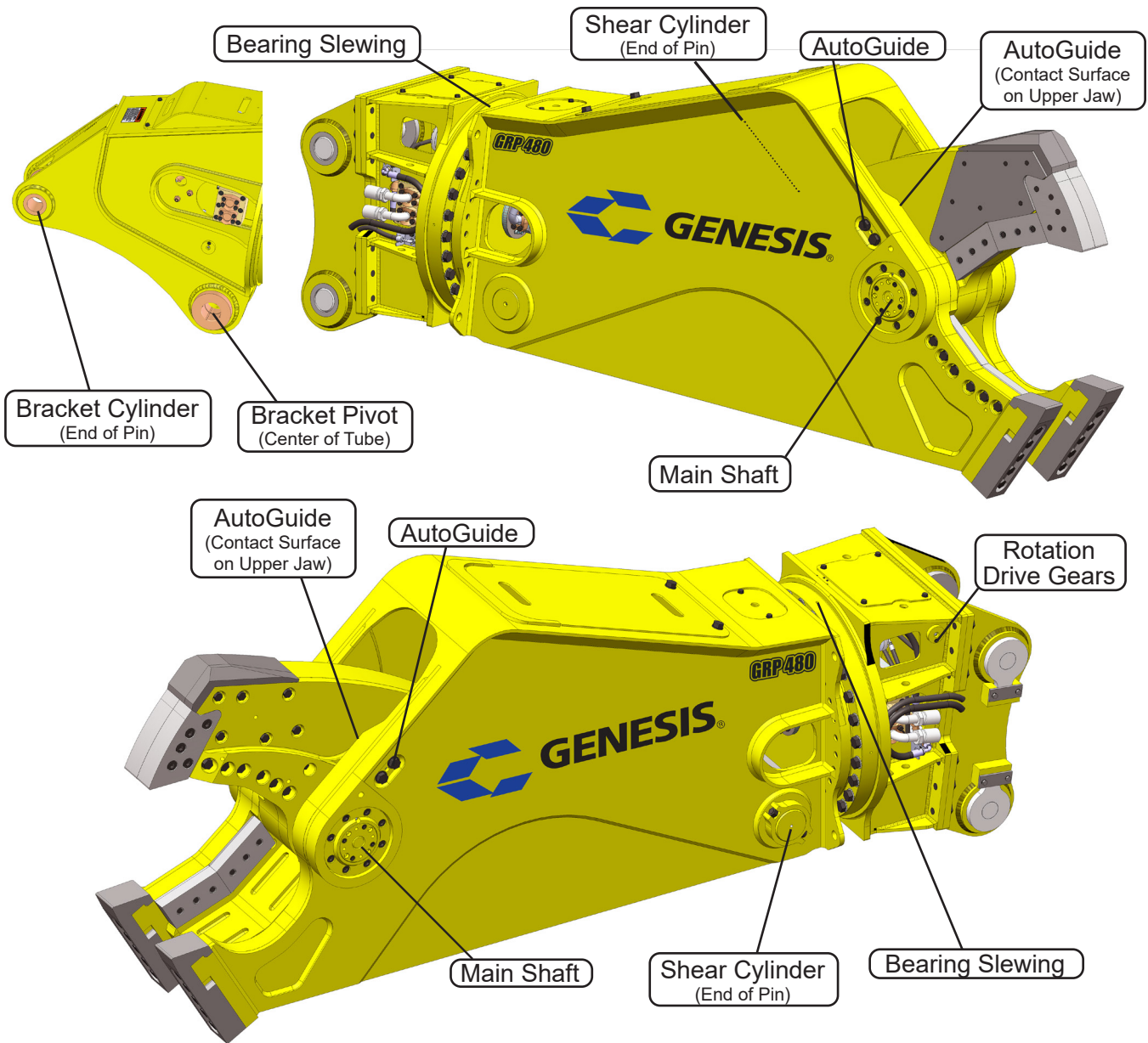

## **BOLT TORQUE SPECS**

**Bolt torque specs and thread treatment procedures can be found in the  
Genesis Fastener Manual.  
[genesisattachments.com/manuals](https://genesisattachments.com/manuals)**

## BLADE MAINTENANCE

Blade and blade seat maintenance greatly affects performance. To maximize cutting performance and optimize the life of replaceable parts, follow this specific sequence of checks, adjustments and maintenance.

1. AutoGuide - shim to tolerance and replace when shims exceed 0.100".
2. Piercing Blades - replace or rebuild when edges are worn, see page 38.
3. Primary and Secondary Blades - rotate, shim to tolerance and replace when all edges are worn. All four blades are identical on shears featuring dual guide blades.
4. Jaw Hard-surfacing - if not using Shear Jaw Armor®, build-up and hard-surface as needed. If using Shear Jaw Armor®, build-up jaws if necessary before replacing.
5. Lower Jaw Tusks - replace or rebuild when edges are worn, see page 38

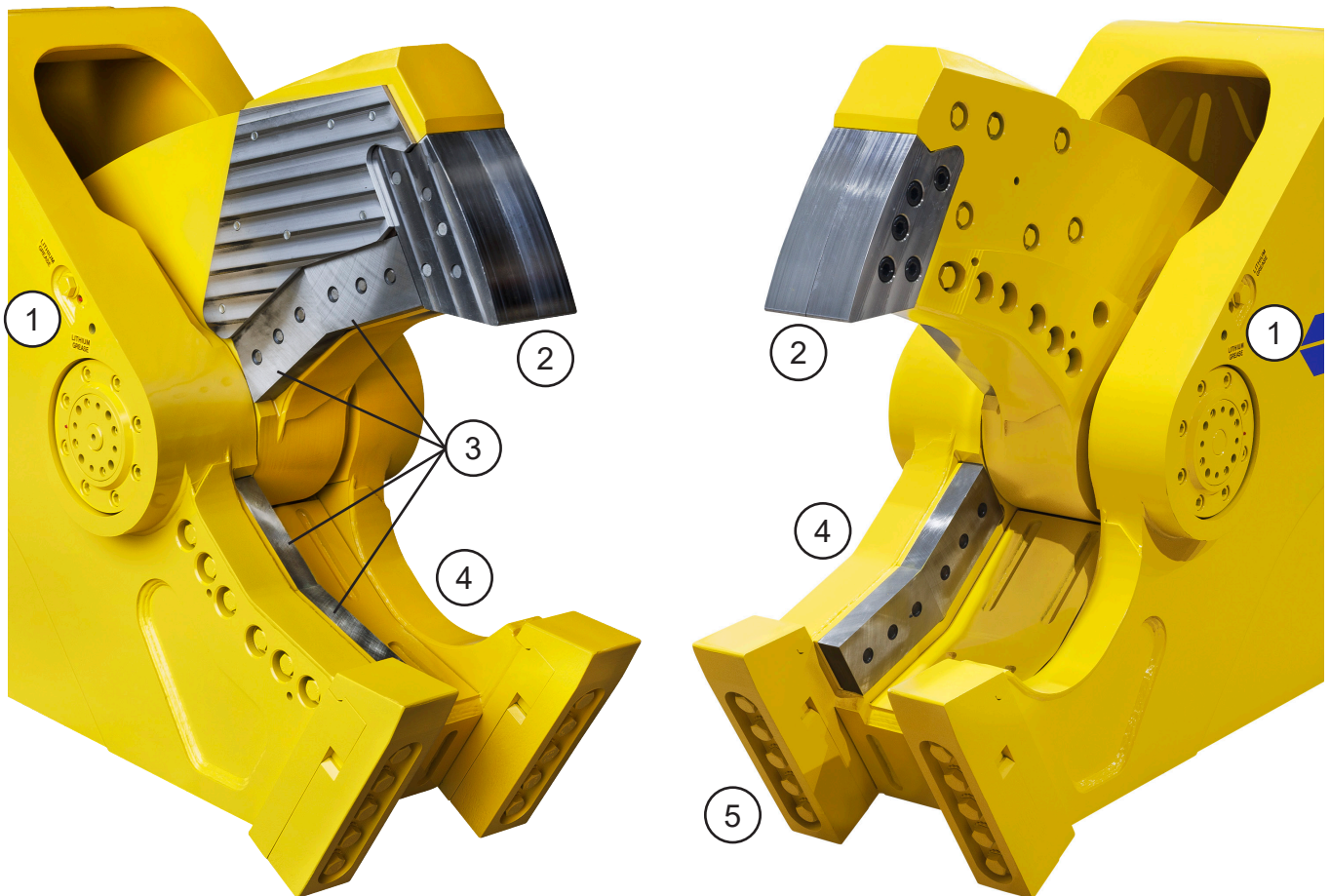

## AUTOGUIDES

The AutoGuides (or pucks) make light contact with the wear surface on both sides of the upper jaw to maintain proper jaw alignment. Check the pucks daily for wear or damage, replacing when grease grooves are no longer visible.

Tolerances between each puck and the mating wear surface should be 0.005" to 0.010".

- ✓ Check tolerances every eight hours of operation and shim as needed.
- ✓ Never overtighten the puck against the wear surface.
- ✓ Perform puck maintenance and shimming before performing blade maintenance.

### AutoGuide Adjustment Procedure

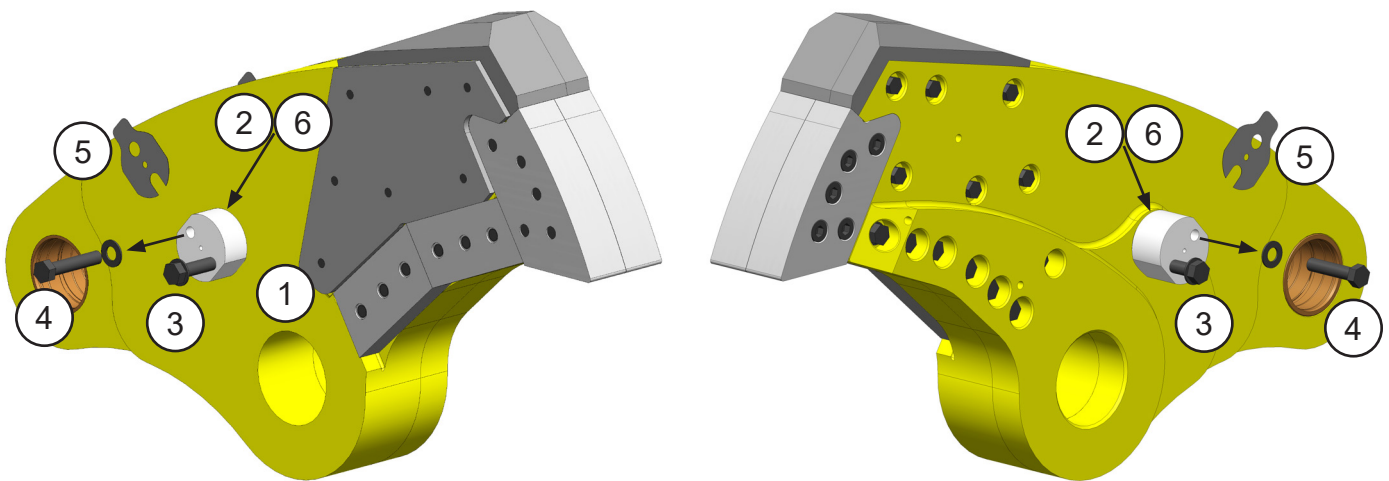

**Use the following procedure to maintain the proper gap and shim the puck.**

1. Slowly close the upper jaw until the puck is centered on the wear area.
2. Check the gap, using a feeler gauge or shims.
3. Loosen the bolts on the outside of the stick.
4. Completely remove the upper bolt.
5. Insert shims, insert top bolt, tighten both bolts.
6. Check gap with feeler gauge.

## UPPER PIERCING BLADES & LOWER JAW TUSKS

On the GRP 480, the piercing blades are primarily used in sorting/separating rebar bundles. As they are not cutting blades, unlike for standard shears, their main purpose is to protect the upper jaw from wear and provide a replaceable wear surface.

Being non-cutting, the amount of wear on these blades is less important than on a standard shear. These piercing blades can be built up and reused to reduce wear kit costs.

### Use the following procedure to check for wear.

1. Check the condition of the piercing blades with a straight edge and tape measure. Piercing blades can wear down to  $\frac{5}{8}$  inch on the front edge and 1 inch on the bottom edge, measuring from the inside edge.
2. Check the condition of the lower tusks with a straight edge and tape measure. Tusks can wear down to  $1\frac{1}{4}$  inch on the top and  $1\frac{7}{8}$  inch on the front, measuring from the inside of the tusk.
3. Badly worn blades must be replaced.

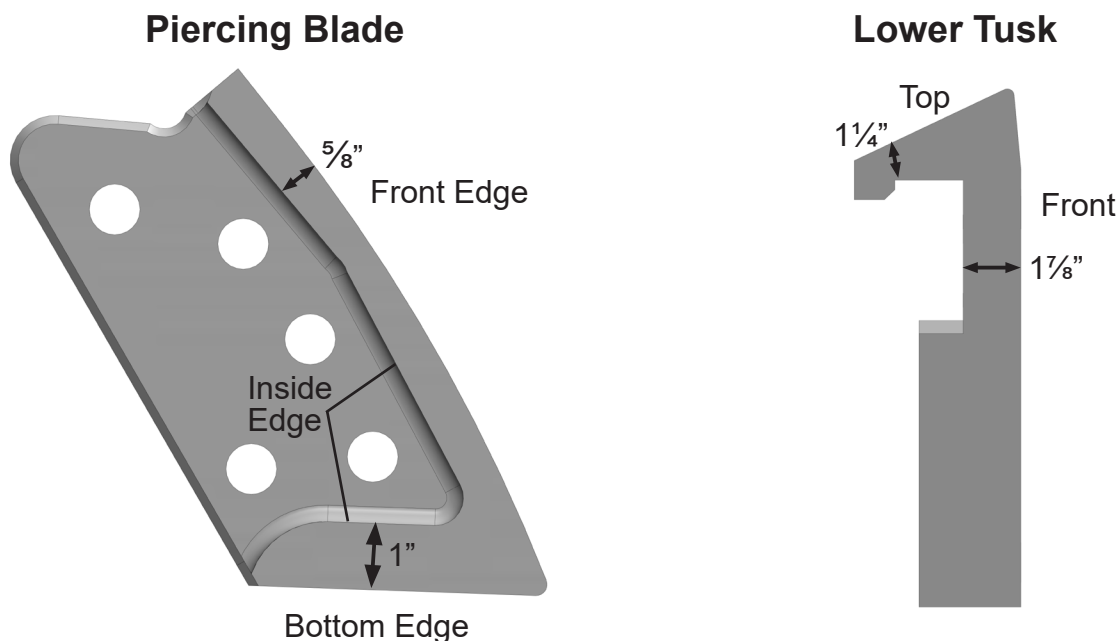

## UPPER PIERCING BLADES

Piercing blades must fit tightly in some areas while having clearance in others.

Areas **Highlighted in Blue** require contact fit to the upper jaw and tang to prevent breaking.

Areas **Highlighted in Red** require an air gap, and blades may occasionally need to be ground down to provide clearance.

Piercing blade contact with the clearance areas (**red**) can cause abnormal stress in the blade. This may cause the piercing and/or guide blades to crack or break.

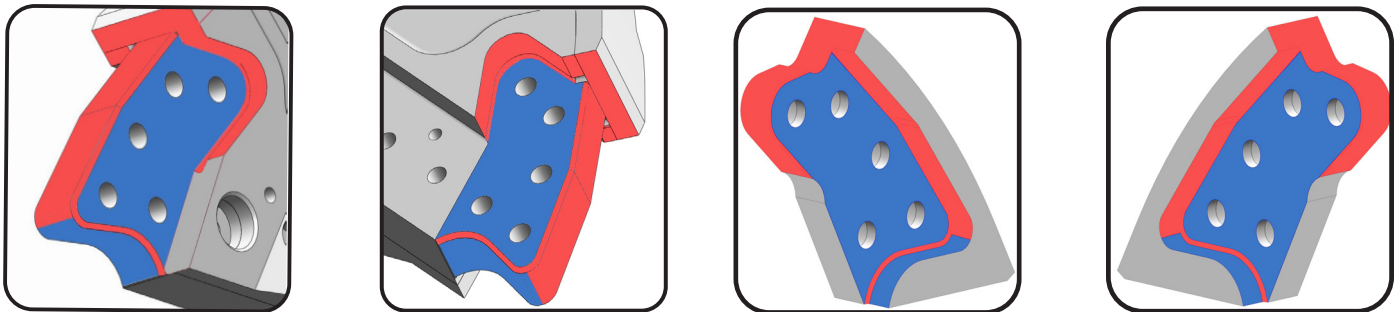

When necessary, build up the front lower edge of the tang (areas **highlighted in yellow**), following the procedures given in this manual. After welding, surfaces should be squared with a grinder and finished with a file and a machinist's straight edge.

It is critical that the piercing blade pocket and tang surfaces are straight and true, without dings, deformations, high or low spots, or areas that are worn away.

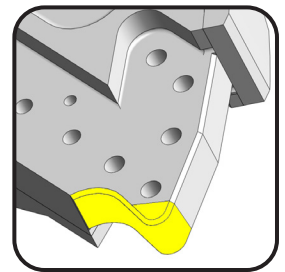

Piercing blade bolts must not make hard contact with the bolt holes in the upper tang. In rare cases it has been noted that improper alignment of piercing blade bolt holes and the bolt holes in the tang can cause the piercing blades to break through the bolt holes.

**When installing the piercing blades, the bolts must be freely installed by hand, not with an air impact wrench.**

The bolts may start freely, but when the bolt shank, which is larger in diameter than the threads, enters the hole in the tang, the interference can cause side loading to the piercing blades. This can cause the tips to break as they try to force the holes apart, or it may force the tips to seat improperly on the tang which can also cause tip failure. This is not a common issue, but one that should be noted as part of routine tip maintenance to prevent unnecessary costs and downtime. If this situation is encountered, contact the Genesis Service Department for further instructions.

## UPPER PIERCING BLADES

### Replacement

1. Remove blades using an air-impact wrench or breaker bar and multiplier.
2. Remove dust and debris from blade seats; wipe down with a rag and solvent.
3. Lightly file deformities from blade seat edges. Do not sand or grind face of blade seats.
4. Install new, clean blades. Lubricate the threaded holes in the blade and on the bottom of the bolt head where it will contact the blade.
5. Snug lubricated blade bolts by hand to hold them in place; push blades up and into the upper and rear surfaces of the seats.
6. Torque bolts to 1/3 of the final torque value.
7. Check for firm contact against blade seats.
8. With a feeler gauge, confirm there is a gap where the blades meet. Gap width by model is shown below the graphic to the right. A very narrow gap may be confirmed by shining a flashlight from below the blades and seeing light pass through. If the gap exceeds the specified limit, call the Genesis Service Department. If no gap exists, remove blades, lightly grind facing surfaces and repeat steps 5-8.
9. Torque bolts to 2/3 final value, and then to final value, using a cross bolt pattern.

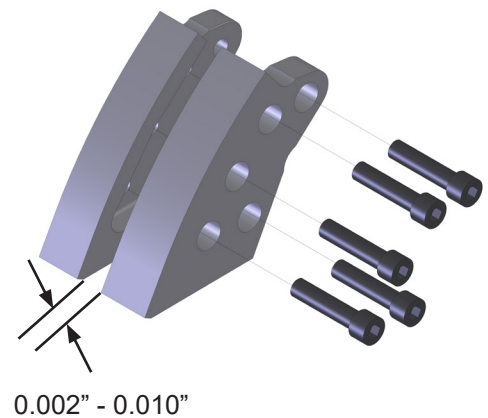

## NOTICE

Piercing blade bolts must be lubricated and torqued as specified in the Genesis Fastener Manual.

Correct clamping force is required to keep tips from moving on their seats. Over-tightening can cause bolt shanks to stretch, losing their clamping force. Loose bolts will cause the seating areas to erode.



## LOWER JAW TUSKS

Lower jaw tusks must fit tightly in some areas while having clearance in others.

Areas **Highlighted in Blue** require contact fit to the upper jaw and tang to prevent breaking.

Areas **Highlighted in Red** require an air gap, and tusks may occasionally need to be ground down to provide clearance.

Tusk contact with the clearance areas (**red**) can cause abnormal stress which may cause the tusk to crack or break.

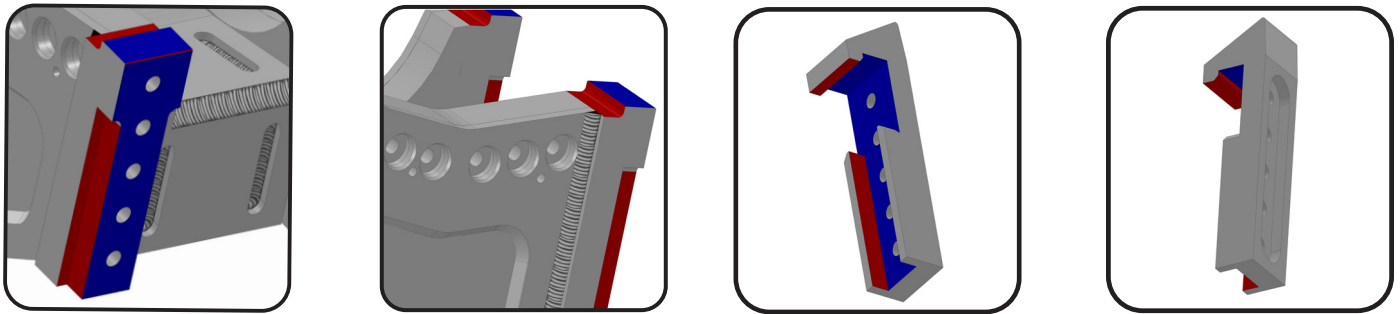

When necessary, build up the front upper edge of the tusk base (areas **highlighted in yellow**), following the procedures given in this manual. After welding, surfaces should be squared with a grinder and finished with a file and a machinist's straight edge.

It is critical that the lower jaw tusk base surfaces are straight and true, without dings, deformations, high or low spots, or areas that are worn away.

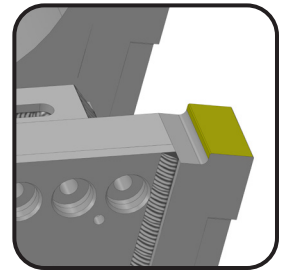

## PRIMARY AND SECONDARY BLADES

Proper maintenance of the primary and secondary blades, or cutting blades, is required for optimal performance. Blade rotation extends blade life and improves cutting performance. Shimming to maintain blade tolerances helps prevent jamming. Dull blades make the excavator hydraulic system work harder and may cause structural damage to the shear.

Inspect blades every eight hours of operation. Re-torque loose bolts and replace broken bolts. Grind away dents or mushrooming of blade edges at the end of each day to prevent upper jaw deflection, excessive blade wear and undue stress to upper and lower jaws.

Rotate blades to use all four cutting edges. Always use Genesis-approved blades. Blades that do not meet Genesis specifications can cause major problems, and using them may void the warranty.

Before performing any blade maintenance, read, fully understand and follow these safety rules.

Wear personal safety equipment including gloves, safety glasses, safety boots and proper clothing.

Safe blade maintenance requires two people - one to steady the blade while the other loosens the bolts.

Blades are heavy and may fall out of the blade seat if not adequately supported. Bystanders must stand clear.

Never strike a blade with a hardened steel tool. The blade may fragment, creating sharp flying debris.

### **Removal**

Loosen the bolts on one blade at a time, enough to loosen the blades.

If blades remain tight, insert a 7/16" brass drift pin into the through-hole on the lower jaw. Tap the drift pin with a hammer until the blade is loose.

Carefully remove bolts and blades.

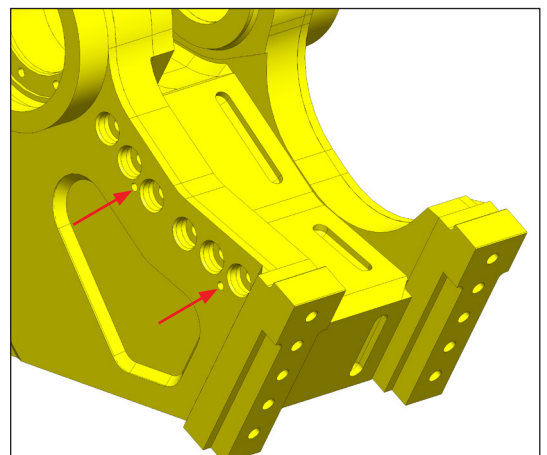

# PRIMARY AND SECONDARY BLADES

## Adjustment Plates

Do not remove the adjustment plates from the lower jaw during routine blade rotation or replacement. These plates are custom-machined for each shear and need only be replaced when lost, damaged or extremely worn.

Inspect the top of each adjustment plate and seat for burrs, nicks or other imperfections that may prevent proper seating of the blades and cause errant blade gap readings. Clean the adjustment plates as necessary.

Replacement plates can be ordered from your Genesis dealer or the Genesis Parts Department with the serial number of your shear. Because adjustment plates are serial number specific and custom machined, Genesis recommends ordering and keeping an extra set on-hand to reduce downtime.

Offset dowel or fastener holes are located in each adjustment plate. When replacing adjustment plates, make sure these holes are aligned with the corresponding holes in the blade seat.

Do not grind blade seat areas.

## Rotation

Rotate blades when the cutting edges are worn to a 1/8" (3 mm) radius.

Recommended rotation intervals are approximately 20-40 hours, depending on the material being processed. Thin materials may require shorter rotation intervals. Blades must be replaced when all four edges are worn to 1/8" (3 mm) radius.

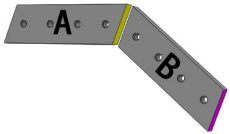
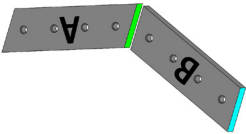
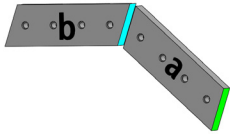
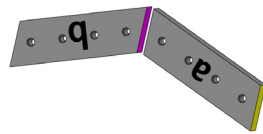
|   |   |  |   |
|---|---|--|---|
| Original Blade Configuration  | First Rotation<br>Rotate both blades end-for-end                                    | Second Rotation<br>Rotate both blades front-to-back and exchange seat positions      | Third Rotation<br>Rotate both blades end-for-end                                      |
|  |  |  |  |

The following chart may be copied and used to track blade rotation.

| 40 - 80 Hours | Date | Hour Meter | Performed By |
|---------------|------|------------|--------------|
| Installed     |      |            |              |
| Rotation 1    |      |            |              |
| Rotation 2    |      |            |              |
| Rotation 3    |      |            |              |

# PRIMARY AND SECONDARY BLADES

## Blade Gap

After each blade rotation, shim the lower blades to keep the gap within the specifications listed in the table below. Do not shim the upper blades. Use only Genesis shim kits.

| GRP Cutting Blade Gaps |         |         |
|------------------------|---------|---------|
| Model                  | Minimum | Maximum |
| 480                    | 0.010"  | 0.020"  |

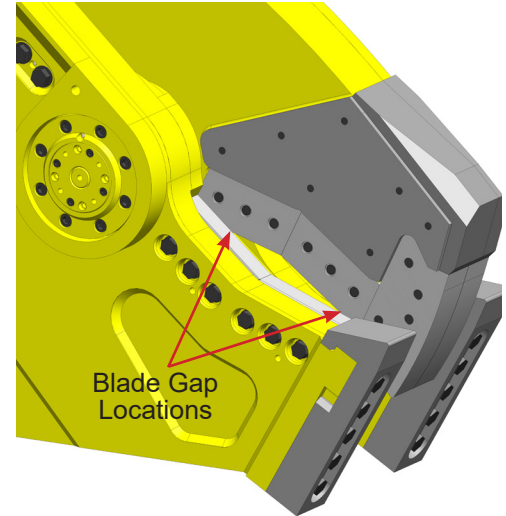

## Blade Gap Measuring Procedure

Slowly close jaws until blades begin to bypass. Stop the jaw and check the gap with a feeler gauge.

Cycle the jaws slowly and continue checking the gap at several points along the entire length of the blades.

Note: The gap will be consistent along the entire length of the blades if they have been rotated and shimmed correctly.

If the blade gap exceeds the maximum listed on the table above, shim the lower blades. Blades must be replaced when shims exceed 0.060".

## Shimming

Loosen blade bolts.

Install shims between the blades and adjustment plates as needed to bring into tolerance.

Torque bolts to spec and recheck the tolerances.

Do not use more than 0.060" of shims.

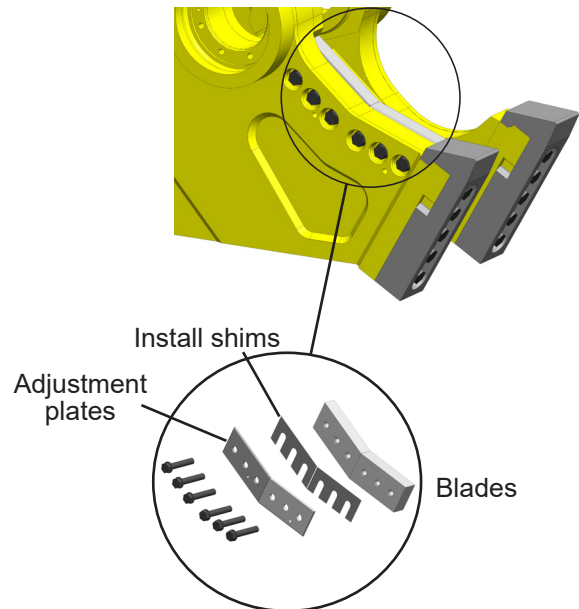

# GENERAL WELDING GUIDELINES

Although the GRP 480 has many bolt-on and weld-on wear components, there may be areas that require build-up and hard-surfacing.

Build-up and hard-surfacing are welding procedures that protect the parent material of the jaws and keep the blades in good adjustment. Build-up is the welding procedure that restores the jaws to their original shape. Building up the jaws helps protect the blades and increases the life of the shear. Hard-surfacing is the welding material added over the parent material (or build-up material) to create a wear-resistant surface.

Welding should not be performed until the jaws are work-hardened. Work-hardening can take up to 80 hours. However, jaws must not wear lower than the height of a new blade. If either jaw wears down lower than blade height, immediately stop operating the shear and perform build-up and hard-surfacing as described in the following pages of this manual.

**When welding around blade seats or the piercing tip tang area, maintain the factory machined seat radius. If the rounded grooves are welded up, use a die grinder with a carbide tool to recut these areas to their original profile. Leaving a squared edge will eventually cause structural cracking. The radius provides a broader area to absorb structural stress.**

## Welding Ground Clamp

**Disconnect all battery ground cables or shut off master battery switch, if equipped. Failure to do so may cause excavator electrical problems, including permanent damage to onboard computer systems.**

**Connect ground clamp as close as possible to the area being welded without allowing current to pass through the pivot group, cylinder pin, cylinder, swivel, motor, gearbox or slewing ring.**

**If you are welding on the lower jaw, connect weld clamp to the lower. If you are welding on the upper jaw, connect to the upper but not to the cylinder clevis. If needed, weld a piece of steel to the area for the grounding clamp and cut the piece off when welding is completed.**

## Welding Rules

Before you begin:

- Remove adjacent blades, as preheating and welding may cause blade damage.
- Wearing an approved respirator, grind the area to clean it, removing all existing hard-surfacing.
- Preheat area to 350° F (177° C). Maintain this temperature throughout the procedure. Do not exceed 450° F (232° C) interpass temperature.

During welding:

- Always grind and weld with the grain of the material.
- Peen each weld pass to relieve stress and harden the welds.
- Do not undercut the ends of the welds.
- Do not start or stop welds directly above a bolt hole or in the apex of the jaw.

After welding maintenance is complete:

- Cover the area with a heat blanket and allow it to cool slowly, approximately eight hours.
- Do not put the shear into operation until the welds have been allowed to cool.

## BUILD-UP

Shear Jaw Armor® is standard on the GRP 480, making build-up and hard-surfacing normally unnecessary. The Jaw Armor, however, still has to be maintained.

If Jaw Armor is not used or a piece is missing, perform build-up and hard-surfacing.

Procedure:

Follow the General Welding Guidelines and Rules.

Determine the area to build up, using a straight-edge or square. Jaws must not wear lower than the height of a new blade. Use a new blade to help determine build-up height for the jaw.

Build up the jaw to slightly higher than the original parent material profile with E7018. Apply single passes in each line with the grain of the steel, peening after each pass.

Protection strips, or raised areas under or around blade seats, must be built up and maintained during build-up procedure using E7018 or equivalent.

These areas should be maintained between blade height and 0.010" lower than blade height. These areas protect the bottom unused edges of the blades as well as reduce the chance for material to catch on the bottom of the blade during jaw open functions, which causes blades to move in their seats.

Denting, deformation or build-up higher than blades in these areas may cause upper jaw deflection, excessive blade gaps, wear to blade faces and undue stress to upper and lower jaws.

After build-up is complete, grind material to be flush with a new blade.

Note: Closely monitor areas above guide blade bolt countersinks and below front two upper blade bolt countersinks. These are high-wear areas. If allowed to wear too far, parent material starts to fold into the countersinks, and it becomes time-consuming to clean out this area when access is needed for blade rotation and replacement.

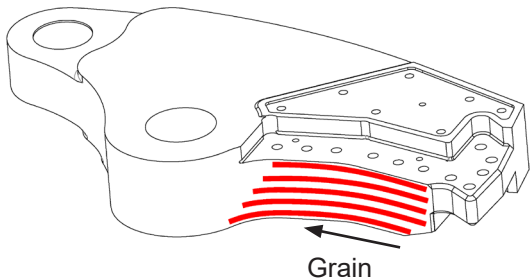

Area highlighted in blue illustrates protection strip.

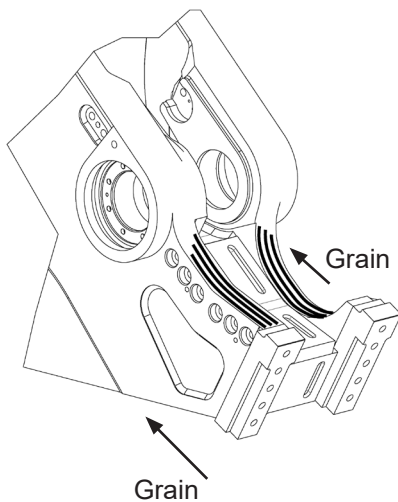

## HARD-SURFACING

Do not apply hard-surfacing directly to the parent material as this could cause toe cracking, and the hard-surfacing will break away.

Procedure:

Follow the General Welding Guidelines and Rules.

Apply a single pass stringer bead pattern, with the grain, using E7018 electrode. Peen each pass.

Do not apply a stringer directly on the edge. Start the first pass 1/4" from the edge.

Stagger the ends of the stringer welds so they do not end in a straight line.

Cap each stringer bead with one pass of GenWire or GenRod to hard-surface. Do not apply more than two layers of hard-surfacing. Peen each pass.

Grind the ends of all stringer welds with the grain to taper 1" to 1-1/2" (25 - 38 mm) to the parent material.

See the following page for hard-surfacing illustrations and instructions specific to each area of the jaws.

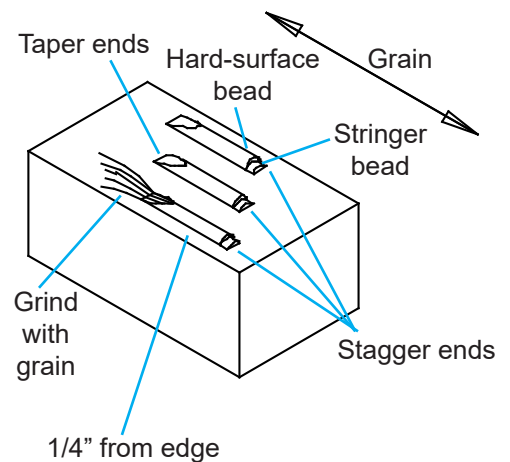

# HARD-SURFACING PATTERNS

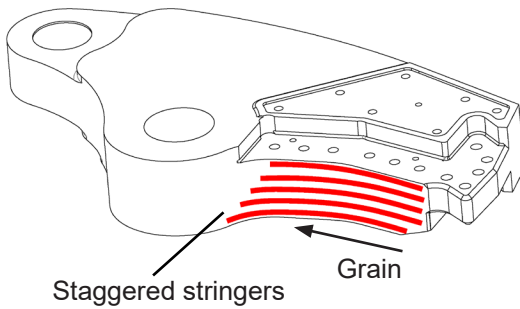

## Upper Jaw

Single passes approximately 1" apart. Begin just behind the piercing blade seats and continue toward the throat. Use three to five stringers, depending on the shear model.

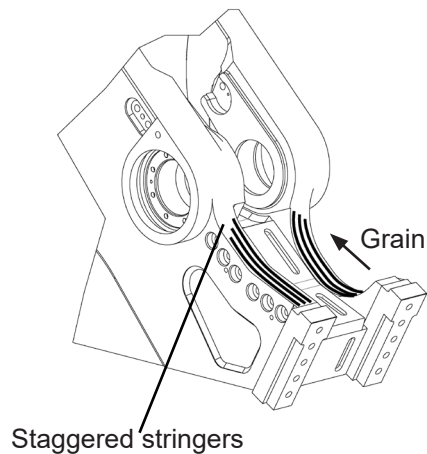

## Lower Jaw

Single passes approximately 1" apart. Work across the top of the chin plate and along the lower jaw toward the throat. Use two to three stringers, depending on the shear model.



# HYDRAULIC/ROTATION MAINTENANCE

## Hydraulic Requirements

Operating the shear below the recommended flow and/or pressure range will adversely affect performance and may damage the rotate motor.

**Operating the shear above the recommended flow and/or pressure range may damage the shear and its hydraulic components.**

| <b>GRP Model</b> | <b>Flow</b>               | <b>Pressure</b>              |
|------------------|---------------------------|------------------------------|
| 480              | 70-160 GPM<br>264-605 LPM | 4500-5500 PSI<br>310-380 Bar |

## Rotation Valve Input

For cooler and more efficient hydraulic system operation, set the input pressure as indicated in the chart below. The maximum case drain measured at the shear while rotating and cycling the jaws must never exceed 80 PSI. Pressure increases during cold-weather operation.

| <b>GRP Model</b> | <b>Flow</b>           | <b>Pressure</b>              |
|------------------|-----------------------|------------------------------|
| 480              | 8-12 GPM<br>30-45 LPM | 1800-2000 PSI<br>125-138 Bar |

## HYDRAULIC/ROTATION MAINTENANCE

### GenFlow Regeneration Valve

Your regeneration valve features a GenFlow adjustment cartridge to control the timing of the shift between speed and power modes. When the cartridge is properly set, the shear closes rapidly until it begins to cut. The valve shifts, slowing jaw close and increasing power. You may hear a squeal or hiss as this happens. The valve shifts back into speed mode after the cut is complete.

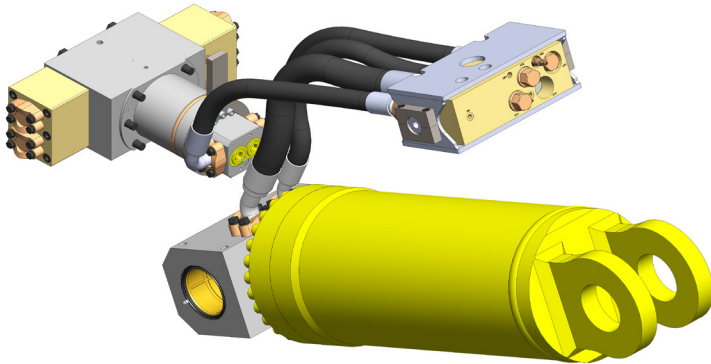

The cartridge is factory-set, turned out approximately seven turns. This setting is appropriate for most applications. However, the cartridge may be custom-set if necessary. Contact Genesis before adjusting a new shear.

### Regeneration Valve Adjustment

Check the cycle time when the hydraulic fluid is warmed up, timing from full open to full closed and back to full open.

To shift into power mode sooner, turn adjustment cartridge out (counter-clockwise). To shift into power mode later, turn in (clockwise).



Shut off the excavator and disable the hydraulics per OEM instructions before adjusting the cartridge.

## REGENERATION VALVE ADJUSTMENT

Requires a hydraulic gauge with a range up to 6000 PSI or higher, with the capability to record the maximum pressure achieved.

1. With the excavator at idle speed, open the shear jaw to full open then slowly close to about 12 inches from full open.
2. Shut down the excavator, bleed down all circuits and remove the hydraulic tank cap.
3. Remove the cylinder access cover carefully as it is heavy.
4. Slowly remove the plug marked GB from the front of the block and install the gauge.
5. Install the fill cap on the excavator hydraulic tank.
6. Start the excavator and run at idle speed.
7. Zero out the gauge.
8. Insert material into the jaws to test cut. This must be heavy enough for the shear to shift into the power mode.
9. If you are not operating the shear, maintain a safe distance of at least 75 ft. from the operating shear.
10. Close the jaw all the way and record the gauge reading. This reading should be approximately 1200 - 1500 PSI. If the reading is low, gradually turn the adjustment cartridge in (clock-wise) with a 5 mm allen wrench.

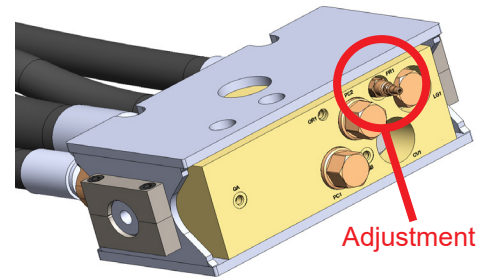

If the reading is high, back out the adjustment cartridge gradually (turning counter-clockwise). Open jaw 3/4 of the way open. Close jaw half-way. Repeat steps 7 - 10 above until the reading is between 1200 - 1500 PSI. Tighten jam nut on adjustment cartridge and repeat procedure several times to assure setting hasn't changed.



### WARNING

The ground crew must be in full view of the operator at all times and must stand clear of the shear jaws when cycling.

## GENFLOW REGENERATION VALVE - HOW IT WORKS

**Jaw Close in Regeneration:** Oil that would normally leave the rod end of the cylinder and return to the tank is diverted to the bore end of the cylinder, increasing flow by approximately 50 percent and speeding up jaw close. In this mode, oil pressure on both rod and bore sides of the cylinder piston are basically equal and, although this speeds up the cylinder extend speed, it results in pressurized fluid on the rod side. If left in this mode, cylinder power is greatly reduced.

**Jaw Close in Power Mode:** To provide full power, when the upper jaw hits the material, the pressure rises. Once pressure exceeds the adjustment cartridge settings, it then shifts the rod oil back to the excavator hydraulic tank instead of the bore end of the cylinder. Pressure in the rod also drops, allowing full force from the bore pressure to be applied to the upper jaw for full cutting.

**Jaw Open:** Oil goes to the rod end of the cylinder, and bore oil goes back to the tank.

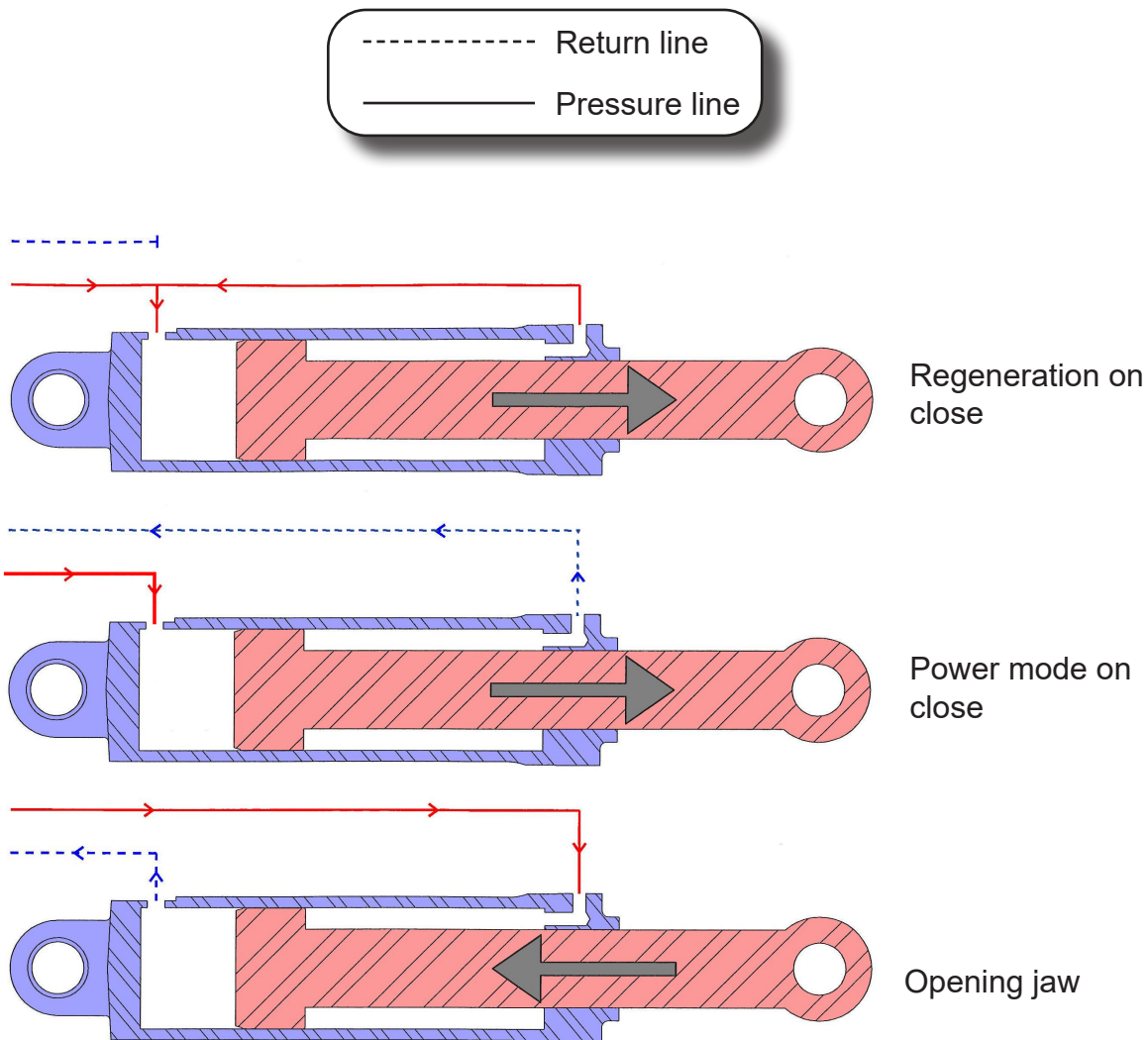

# GENFLOW REGENERATION VALVE - 240 GPM

Pressure Reducing Valve 6300625  
 Seal Kit 6300622  
*Shifts between speed and power modes.*

Torque to  
 30-35 ft-lbs  
 41-47 Nm

Logic Valve 6300623  
 Seal Kit 6300624  
*Directs oil from rod to tank in power mode; blocks oil path from rod to tank in speed mode.*

Torque to  
 454-486 ft-lbs  
 616-659 Nm

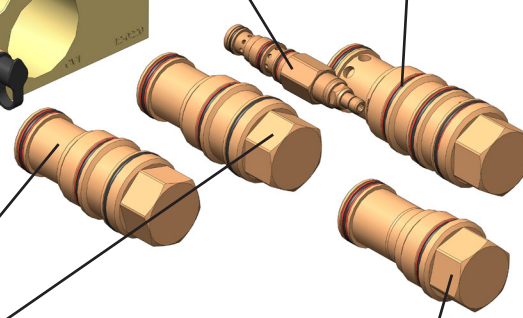
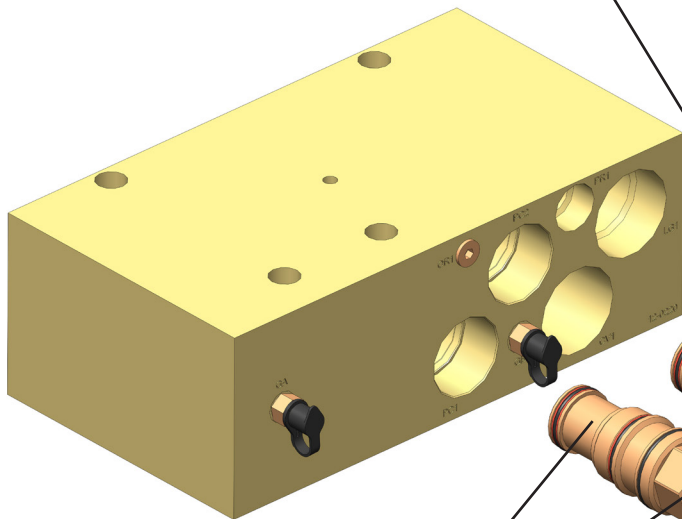

Pilot Check Valve 6380088  
 Seal Kit SK00024  
*Directs oil from rod to bore in speed mode; blocks oil path between rod and bore in power mode.*

Torque to  
 454-486 ft-lbs  
 616-659 Nm

Check Valve 6380011  
 Seal Kit SK00023  
*Directs oil into rod from excavator while retracting; blocks oil path between rod and tank at all times.*

Torque to  
 454-486 ft-lbs  
 616-659 Nm

## SLEWING RING MAINTENANCE

Visually check slewing ring (rotation bearing) bolts every eight hours of operation. Do not reuse or re-torque these bolts. Loose or broken bolts, along with the bolts on either side, must be immediately replaced.

The bolts that secure the slewing ring are critical for safe attachment operation. Improper torque may cause the bolts to fail and the attachment to break free, which may result in serious personal injury and equipment damage. Improper torque will also cause uneven slewing ring wear.

Rotating components must be greased daily. Grease fittings are located on the outside of the slewing ring and on the inside of the rotating head assembly. Grease locations are marked with decals.

Grease each fitting and then rotate the attachment two full rotations.

For normal conditions above 32°F (0°C), use a lithium-based, premium grade 2 extreme-pressure grease. For temperatures below 32°F, use a grade 0 grease. **Do not use grease containing Molybdenum (Moly).**

Genesis GLG-2<sup>®</sup> anti-wear, extreme-pressure lithium grease, PN 6302601, is recommended for all temperature conditions.



Stand clear when the attachment is being rotated. Always stay in clear view of the operator.

## ROTATION WITH CROSSOVER RELIEF VALVE

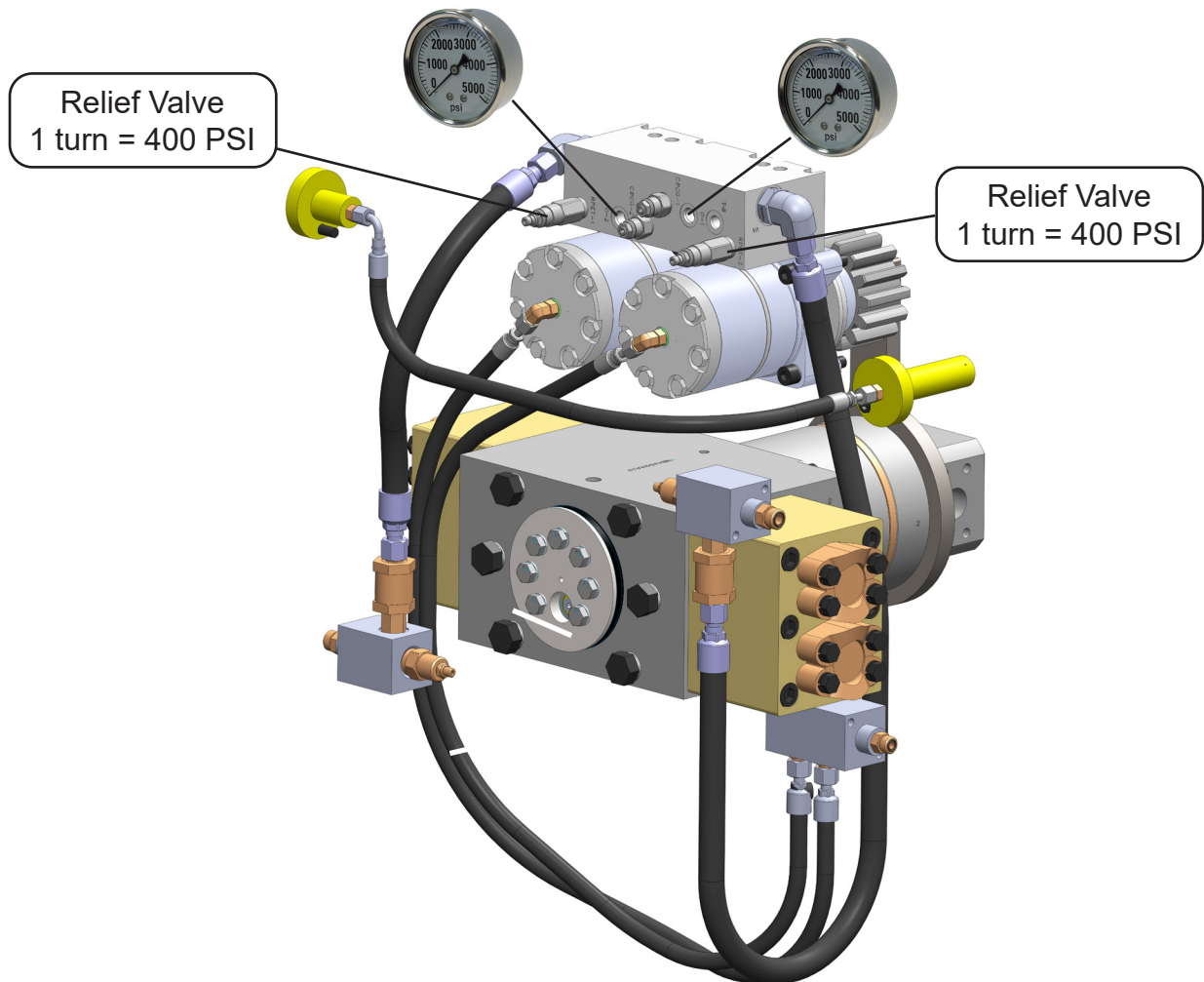

### **Setting the Crossover Reliefs**

1. Increase supply pressure to the rotation valve to 2500 PSI.
2. Install pressure gauges on relief test ports.
3. Plug hoses at motor or secure the shear from rotating.
4. Pressurize the valve to rotate.
5. Adjust the corresponding relief valve to 2200 psi.
6. Repeat for the other direction.
7. Reduce supply pressure to the pressure-reducer valve to 2000 psi.

# TROUBLE-SHOOTING GUIDE

| Symptom   | Possible Causes/Solutions  |
|---|--|
| Low power   | Check operating pressures and back pressure at port blocks on shear  |
|   | Isolate shear from excavator and check excavator pressures at boom tip   |
|   | Shear may be partially stuck in regen mode; follow adjustment procedure in this manual   |
|   | If speed is good with low power, internal seals on logix cartridge may need to be replaced   |
|   | Possible cylinder, swivel or regen bypass (contact the Genesis Service Department for procedures)  |
| Slow jaw open with low power                                | Pilot check valves in the regen valve may have worn or damaged seals   |
| Slow jaw close  | Check hydraulic flows from excavator   |
|   | Check regen valve adjustment if shear is new   |
|   | Adjustment cartridge may have damaged seals or may be stuck open   |
|   | Regen check valve or logix valve may have damaged seals or may be stuck open   |
| Good speed but shear stalls before cutting                  | Regen adjustment cartridge is turned in too far, not shifting out of regen mode  |
| Jaw drifts closed or can be pushed closed                   | Regen bleed down orifice may be plugged  |
|   | Regen pilot check valves may be leaking  |
|   | Directional valve on excavator may be leaking  |
| Jaw closes suddenly and will not open                       | Ball valve may be closed on excavator  |
|   | Regen pilot check valves may be contaminated   |
|   | Excavator valve spool may be stuck   |
|   | If shear has quick-coupled hydraulics, they may be partially disconnected or damaged   |
| Hydraulics chatter while cutting                            | Tighten regen adjustment cartridge in quarter-turns and recheck speed  |
|   | Chattering may indicate a material jam   |
| Jaw bounces back after hitting excavator relief on jaw open | Regen bleed down orifice is plugged  |
|   | Regen logix cartridge needs to be replaced/cylinder or swivel seal failure   |
| Loud bang when shifting to speed mode                       | Broken spring or poppet in logix cartridge (regen valve)   |
| Hydraulic system overheating                                | Check hydraulic system oil level for low or overfull condition   |
|   | Ensure clear path for hydraulic cooler-radiator and A/C condenser; clean coolers and radiator with compressed air and then pressure wash   |
|   | Check with excavator dealer on whether a hot weather package needs to be installed on the excavator. Note oil temperatures coming out of the shear can run as high as 230 to 240 degrees Fahrenheit. |



## TROUBLE-SHOOTING GUIDE

| Symptom          | Possible Causes/Solutions  |
|------------------|--|
| Poor Cutting     | Material is beyond shear appetite range  |
|                  | Material is harder than rebar  |
|                  | Blades are worn beyond 1/8" radius - rotate or replace   |
|                  | Blade gaps are too wide for thin material  |
|                  | Too much end play in pivot group - shim to 0.002" to 0.005"  |
|                  | Wear in main bearings is causing jaw deflection and inconsistent blade gaps  |
|                  | Pressures from excavator too low - check at shear port blocks  |
|                  | Shear not kicking out of regeneration or kicking out at too high a pressure range - see Regeneration Valve section of manual |
|                  | Shear swivel or cylinder is bypassing - contact the Genesis Service Department for procedures to check for bypass            |
| Material Jamming | Excessive blade gaps - shim to specs given in Cutting Blade section of manual  |
|                  | Worn blades - rotate or replace  |
|                  | Thin material may be wrapping around blades - fold material or draw a larger amount of material into jaws                    |

## TROUBLE-SHOOTING GUIDE

| Symptom                                      | Possible Causes/Solutions  |
|--|--|
| Does not rotate                              | Blown fuse   |
|  | Test for 24V at plugs on directional valve while depressing foot switch  |
|  | Incorrect pressure settings; reset   |
| Does not rotate in one direction             | No electrical power to one side; test for 24V at plugs on directional valve while depressing foot switch                   |
|  | Check if directional control valve shifts both ways while actuating foot switch in both directions                         |
| Rotator chatters                             | Electrical short; back out flow controls   |
|  | Pressure settings too high; reset  |
|  | Power to both rotation solenoids at the same time; test for 24V at plugs on directional valve while depressing foot switch |
| Rotates faster in one direction              | One flow control cartridge is set higher than the other; reset   |
| Rotates too fast or too slow                 | Flow control out of adjustment; reset  |
| Rotation speed changed from original setting | Jam nut loosened on rotation valve   |
|  | Faulty cartridge (contamination)   |
|  | Faulty directional control valve   |
|  | Pressure set too low; reset  |

# WARRANTY

## **Claim Procedure**

Notify the Genesis Service Department of the potential warranty claim prior to making the repair. Digital pictures are very helpful for diagnosing problems and recommending repairs.

Contact the Genesis Service Department before making alterations, changes or repairs to any component that is going to be considered for warranty. Not doing so will void all Genesis warranty consideration.

The Genesis Service Department will issue an authorization number to track the repair costs, outgoing parts, and/or defective parts returning to the factory.

Replacement parts must be ordered using a purchase order number. Shipping is standard ground. Overnight shipping is available by request, and Genesis will not cover the shipping charge.

When the repair is complete, submit an invoice to the Genesis Service Department within 30 days. Include itemized internal labor reporting, parts lists and invoices for outside contractors. Reference the authorization number on all invoices.

When returning parts for warranty consideration, include a copy of any related Genesis paperwork along with any other necessary documentation to ensure proper processing and credit. The Genesis Service Department will provide the necessary forms.

Your account will be credited when the warranty claim is accepted.

## **Blade Warranty**

Standard warranty on blades will only be considered on the first edge, and wear on the edge must be 1/8" radius or less. Genesis does not warranty cutting blades that are cracked or broken from top to bottom (perpendicular to the long edge of the blade). Genesis also does not cover fasteners, the labor to replace wear components or collateral damage, such as blade seats, from broken blades, the piercing blade tang or adjustment plates.

**Please direct any questions to the Genesis Service Department: 715-395-5252**

# PARTS ORDER POLICY AND PROCEDURE

## **Parts Orders Should Include**

- Purchase order number
- Model and serial number of attachment
- Part number and quantity needed
- Shipping and billing address
- Method of shipment or required delivery date

## **Placing Orders**

Orders may be placed by phone or e-mail. To e-mail an order, use the form on the following page or your purchase order form. Contact information is located at the front of this manual.

## **Part Numbers**

Part numbers are listed in a separate Parts Manual or, if included, the Parts section of this manual. Contact the Genesis Parts Department with questions regarding part numbers, availability and pricing.

## **Shipping**

All orders will be shipped best way surface unless an alternate shipping method is requested. Shipping charges are not included in the purchase price of parts.

## **Invoices**

All invoices are due upon receipt. Any accounts with invoices open beyond 60 days are subject to review and may be placed on C.O.D. status without further notice.

## **Returns**

Many unused Genesis parts may be returned with proper documentation. Return shipping is the responsibility of the purchaser. Credit will be issued upon return, less a 25% restocking fee. Documentation is required for credit of returned parts. Contact the Genesis Service Department at 715-395-5252 for an RGA (Return Goods Authorization) number and form. An RGA must accompany every return. Items shipped without an RGA may be returned to sender.

## **Warranty Returns**

All parts returned to Genesis for warranty consideration must be returned with a completed RGA (Return Goods Authorization) provided by the Genesis Service Department. The form needs to be completed in its entirety, including any additional information requested by the Service Department. Return shipping is the responsibility of the sender and will be credited upon claim approval. A determination to accept or deny the claim will be made based upon the information available to Genesis. Warranty on purchased parts other than wear components is 6 months. Genesis does not cover labor costs to replace purchased parts replaced under warranty. There is no warranty period on wear parts or components.



# PARTS ORDER FORM

Customer: \_\_\_\_\_ Date: \_\_\_\_\_

Phone: \_\_\_\_\_ Contact: \_\_\_\_\_

Shipping Address: \_\_\_\_\_ E-mail: \_\_\_\_\_  
 \_\_\_\_\_

\_\_\_\_\_ Billing Address:  
 \_\_\_\_\_  
 \_\_\_\_\_

Purchase Order: \_\_\_\_\_ Shipping Method: \_\_\_\_\_

Model: \_\_\_\_\_ Serial Number: \_\_\_\_\_

| Quantity | Part Number | Description | Price |
|----------|-------------|-------------|-------|
|          |             |             |       |
|          |             |             |       |
|          |             |             |       |
|          |             |             |       |
|          |             |             |       |
|          |             |             |       |
|          |             |             |       |
|          |             |             |       |
|          |             |             |       |
|          |             |             |       |
|          |             |             |       |
|          |             |             |       |
|          |             |             |       |
|          |             |             |       |
|          |             |             |       |

E-mail to the Genesis Parts Department: [genesisparts@genesisattachments.com](mailto:genesisparts@genesisattachments.com)  
 For assistance, call 715-395-3488



**GENESIS®**

The Promise of Performance.

## CONTACT INFORMATION

### Genesis Attachments

1000 Genesis Drive  
Superior, WI 54880 USA

Toll Free: 888-SHEAR-IT  
(888-743-2748)

Phone: 715.395.5252

E-mail:  
info@genesisattachments.com

### Europe/Africa/Middle East Genesis GmbH

Teramostrasse 23  
87700 Memmingen, Germany

Phone: +49 83 31 9 25 98 0

Fax: +49 83 31 9 25 98 80

genesis-europe.com

E-mail:  
info@genesis-europe.com

### Asia Pacific Representative Office

24 Upper Serangoon View #12-28  
Singapore 534205

Phone: +65 9673 9730

E-mail:  
tchoo@genesisattachments.com

### Central America & Colombia

Cra 13A #89-38 / Ofi 613  
Bogota, Colombia

Phone: +57 1 610 8160 / 795 8747

E-mail:  
contact@themsagroup.com

View and download all manuals: [genesisattachments.com/manuals](http://genesisattachments.com/manuals)

Patents: [genesisattachments.com/products/patents](http://genesisattachments.com/products/patents)

Rev. 3-27-25