



# GDP 655 DemoPro

## SAFETY & OPERATOR'S MANUAL



## CONTACT INFORMATION

### Genesis Attachments

1000 Genesis Drive  
Superior, WI 54880 USA

Toll Free: 888-SHEAR-IT  
(888-743-2748)

Phone: 715.395.5252

E-mail:  
info@genesisattachments.com

### Europe/Africa/Middle East Genesis GmbH

Teramostrasse 23  
87700 Memmingen, Germany

Phone: +49 83 31 9 25 98 0  
Fax: +49 83 31 9 25 98 80  
genesis-europe.com

E-mail:  
info@genesis-europe.com

### Asia Pacific Representative Office

24 Upper Serangoon View #12-28  
Singapore 534205

Phone: +65 9673 9730

E-mail:  
tchoo@genesisattachments.com

### Central America & Colombia

Cra 13A #89-38 / Ofi 613  
Bogota, Colombia

Phone: +57 1 610 8160 / 795 8747

E-mail:  
contact@themsagroup.com

View and download all manuals: [genesisattachments.com/manuals](http://genesisattachments.com/manuals)  
Patents: [genesisattachments.com/products/patents](http://genesisattachments.com/products/patents)

## PREFACE

To ensure years of safe, dependable service, only trained and authorized persons should operate and service your Genesis attachment. It is the responsibility of the product's owner to ensure the operator is trained in the safe operation of the product and has available this manual for review. It is the responsibility of the operator and maintenance personnel to read, fully understand and follow all operational and safety-related instructions in this manual. The attachment should not be operated until you have read and fully understand these instructions. Always use good safety practices to protect yourself and those around you.

### **Important**

This operator's manual must accompany the attachment at all times and be readily available to the operator.

### **Manual Replacement**

Should this manual become damaged or lost or if additional copies are required, immediately contact any authorized Genesis dealer or the Genesis Service Department at 888-743-2748 or 715-395-5252 for a replacement.

### **Registration Form**

The Warranty Registration Form must be filled out by the dealer or customer and returned to Genesis indicating the date the attachment went into service.

### **Possible Variations**

Genesis cannot anticipate every possible circumstance that might involve a potential hazard as the owner's requirements and equipment may vary. Therefore, the warnings in this publication and on the product may not be all-inclusive, and you must satisfy yourself that the procedure, application, work method or operating technique is safe for you and others before operating.

### **Public Notice**

Genesis reserves the right to make changes and improvements to its products and technical literature at any time without public notice or obligation. Genesis also reserves the right to discontinue manufacturing any product at its discretion at any time.

### **Warranty**

All work or repairs to be considered for warranty reimbursement must be pre-authorized by the Genesis Service Department. Any alterations, modifications or repairs performed before authorization by the Genesis Service Department will render all warranty reimbursement consideration null and void without exception. See page 57 for Warranty Claim Procedures.

Improper operation or improperly performed maintenance may render any warranty null and void.

# TABLE OF CONTENTS

<b>CONTACT INFORMATION</b> .....	<b>2</b>
<b>PREFACE</b> .....	<b>3</b>
Important.....	3
Manual Replacement.....	3
Registration Form.....	3
Possible Variations.....	3
Public Notice.....	3
Warranty.....	3
<b>SAFETY STATEMENTS</b> .....	<b>7</b>
<b>OPERATIONAL SAFETY</b> .....	<b>8</b>
Read Manual Before Operating or Maintaining the Attachment.....	8
Personal Protection.....	8
Know Your Equipment.....	8
Before Operating.....	8
Check the Equipment.....	9
Stability.....	9
Know the Work Area.....	10
Starting Procedure.....	10
Place the Load Safely.....	10
Safely Operate Equipment.....	11
Transporting the Attachment.....	12
Equipment Condition.....	12
Working Overhead.....	12
Power Lines.....	12
Use Care with Hydraulic Fluid Pressure.....	13
Prioritized Oil Flow.....	14
Emergency Situations.....	14
Unsafe Conditions.....	14
Crystalline Silica Dust.....	14
Prop. 65 Warning for California Residents.....	14
Process Material Safely.....	15
Lift the Load Safely.....	15
Place the Load Safely.....	15
<b>ATTACHMENT NOMENCLATURE</b> .....	<b>16</b>
<b>ROTATION LOCK</b> .....	<b>18</b>
<b>LIFTING LUG LOCATIONS</b> .....	<b>19</b>
<b>ATTACHMENT INSTALLATION</b> .....	<b>20</b>
<b>ROTATOR INSTALLATION</b> .....	<b>21</b>
Foot Switch Installation.....	21
Rotation Circuit - Radial Piston/Gerotor Motor.....	22
Rotation Circuit - Auxiliary Valve on Machine.....	23
<b>HYDRAULIC START-UP</b> .....	<b>24</b>
Start-up Procedure.....	24
<b>GENERAL OPERATION INSTRUCTIONS</b> .....	<b>25</b>
Start-up.....	25
Efficient and Productive Operation.....	25

# TABLE OF CONTENTS

<b>COMMON OPERATIONAL CONCERNS</b> .....	<b>26</b>
Cutting Larger Materials.....	26
Chatter While Cutting.....	26
Pulling / Back-Tracking.....	27
Pushing / Tracking Forward.....	28
Cutting in a Pile.....	29
<b>MAINTENANCE SAFETY</b> .....	<b>30</b>
<b>MAINTENANCE SCHEDULE</b> .....	<b>32</b>
Scheduled Maintenance.....	32
Four-Hour Checklist.....	33
Eight-Hour Checklist.....	33
<b>LUBRICATION POINTS</b> .....	<b>34</b>
<b>BOLT TORQUE SPECS</b> .....	<b>35</b>
<b>JAW AND BLADE MAINTENANCE</b> .....	<b>36</b>
Blade Bolts.....	36
<b>UPPER TIP BLADES</b> .....	<b>37</b>
Upper Tip Blades.....	37
Blade Fuse.....	37
Replacement.....	39
<b>GUIDE BLADES</b> .....	<b>40</b>
Shimming.....	40
Rotation.....	40
Replacement.....	40
Adjustment Plates.....	41
<b>CUTTING BLADES</b> .....	<b>42</b>
Removal.....	42
Rotation.....	43
Blade Gap.....	44
Blade Gap Measuring Procedure.....	44
Shimming.....	44
<b>RAZOR BLADE</b> .....	<b>45</b>
<b>GENERAL WELDING GUIDELINES</b> .....	<b>46</b>
Welding Ground Clamp.....	46
Welding Rules.....	46
<b>BUILD-UP</b> .....	<b>47</b>
<b>HARD-SURFACING</b> .....	<b>48</b>
<b>HARD-SURFACING PATTERNS</b> .....	<b>49</b>
<b>HYDRAULIC/ROTATION MAINTENANCE</b> .....	<b>50</b>
Hydraulic Requirements.....	50
Rotation Valve Input.....	50
GenFlow Regeneration Valve.....	51
Regeneration Valve Adjustment.....	51
<b>GENFLOW REGENERATION VALVE - HOW IT WORKS</b> .....	<b>52</b>
<b>GENFLOW REGENERATION VALVE</b> .....	<b>53</b>
<b>SLEWING RING MAINTENANCE</b> .....	<b>54</b>
<b>TROUBLE-SHOOTING GUIDE</b> .....	<b>55</b>

## TABLE OF CONTENTS

<b>WARRANTY</b> .....	<b>57</b>
Claim Procedure.....	57
Blade Warranty.....	57
<b>PARTS ORDER POLICY AND PROCEDURE</b> .....	<b>58</b>
Parts Orders Should Include.....	58
Placing Orders.....	58
Part Numbers.....	58
Shipping.....	58
Invoices.....	58
Returns.....	58
Warranty Returns.....	58
<b>PARTS ORDER FORM</b> .....	<b>59</b>
<b>TOOL LIST</b> .....	<b>60</b>
<b>CONTACT INFORMATION</b> .....	<b>61</b>

### NOTICE

For bolt torque specs, see the Genesis Fastener Manual.  
[genesisattachments.com/manuals](https://genesisattachments.com/manuals)

## SAFETY STATEMENTS



This symbol by itself or used with a safety signal word throughout this manual is used to call attention to instructions involving your personal safety or the safety of others. Failure to follow these instructions can result in injury or death.



**DANGER**

This statement is used where serious injury or death will result if the instructions are not followed properly.



**WARNING**

This statement is used where serious injury or death could result if the instructions are not followed properly.



**CAUTION**

This statement is used where minor or moderate injury could result if the instructions are not followed properly.

**NOTICE**

This statement is used where property damage could result if the instructions are not followed properly.

# OPERATIONAL SAFETY

## Read Manual Before Operating or Maintaining the Attachment



Read this manual before attempting to operate the attachment. This operator's manual should be regarded as part of the attachment. For proper installation, operation and maintenance of the attachment, operators and maintenance personnel must read this manual.



## **WARNING**

Serious injury or death could result if appropriate protective clothing and safety devices are not used.

## Personal Protection

Use protective clothing and safety devices appropriate for the working conditions. These may include but are not limited to:

- ✓ Hard hat
- ✓ Safety glasses, goggles or face shield
- ✓ Hearing protection
- ✓ Safety shoes
- ✓ Heavy gloves
- ✓ Reflective clothing
- ✓ Respirator or filter mask



# Safety matters

## Know Your Equipment



Know your attachment's capabilities, dimensions and functions before operating. Inspect your attachment before operating and never operate an attachment that is not in proper working order. Remove and replace any damaged or worn parts.

## Before Operating

- ✓ Warn all others in the area that you are about to start operation.
- ✓ Perform the Check the Equipment steps outlined in this manual.
- ✓ Check underneath and around the machine. Make sure all personnel and equipment are clear from the area of operation and equipment movement. Check clearances in all directions, including overhead.
- ✓ Be properly seated in the operator's seat.
- ✓ Do not attempt to operate until you have read and fully understand this manual and the OEM manual for the carrier.

# OPERATIONAL SAFETY

## Check the Equipment

Before use, check the equipment to ensure it is in good operating condition.

Check the following:

- ✓ Grease fittings. Pump grease at all fitting locations, see page 34.
- ✓ Hydraulic fluid level. Add hydraulic fluid as required.
- ✓ Hydraulic hoses and hose connections for wear or leaks. Repair or replace any damaged hoses or connections.
- ✓ All control levers for proper operation.
- ✓ Rotation bearing. Visually check for loose or damaged bolts. If repair is required, refer to qualified personnel.
- ✓ Grease rotation bearing and pinion gear.
- ✓ Check for loose or missing pin retaining bolts.
- ✓ Check cylinders for dents (barrel) or dings (rod).



**GOOD  
CONDITION**



**WARNING**

Serious injury or death could result if warnings or instructions regarding carrier stability and the work area are not followed properly.

## Stability

Your Genesis attachment is sized for carrier stability. However, improper operation, faulty maintenance or unauthorized modifications may cause instability.

- ✓ Know the working ranges and capacities of the carrier to avoid tipping.
- ✓ Use the recommended carrier counter weight.

The following conditions affect stability:

- Ground conditions
- Grade
- Weight of attachment
- Contents of attachment
- Operator judgement



For greater stability, knuckle the attachment to bring the load closer to the center of rotation (center of gravity) while lifting. Use extra caution during reaching to avoid tipping.

# OPERATIONAL SAFETY

## **Know the Work Area**

Check clearances in the work area. Keep all bystanders at a safe distance. Do not work under obstacles. Always check your location for overhead and buried power lines or other utilities before operation.

Check ground conditions. Avoid unstable or slippery areas. Position the carrier on firm level ground. If level ground is not possible, position the carrier to use the attachment to the front or back of the carrier. Avoid working over the side of the carrier.

To reduce the risk of tipping and slipping, never park on a grade exceeding 10% (one-foot rise over the span of a ten-foot run).

## **Starting Procedure**

Before operating, walk completely around the equipment to make certain no one is under it, on it or close to it. Keep all bystanders at least 75 feet away from the area of operation and equipment movement. Let all other workers and bystanders know you are preparing to start. DO NOT operate until everyone is clear.

Always be properly seated in the operator's seat before operating any carrier controls.

### **To start:**

- ✓ Make sure all controls are in the center (neutral) position.
- ✓ Be properly seated.
- ✓ Slowly operate all functions to check for proper operation and to bleed air from the hydraulic system.

### **To shut down:**

- ✓ Return your Genesis attachment to a rest position on the ground.
- ✓ Shut off the carrier engine.
- ✓ Work controls in all directions to relieve hydraulic pressure, per excavator manufacturer's instructions.



## **WARNING**

Serious injury or death could result if warnings or instructions regarding safe operation are not followed properly.

## **Place the Load Safely**

Do not move the attachment, or anything held in the jaws, over people, equipment or buildings. Do not throw or drop the contents. Operate the controls smoothly and gradually.

# OPERATIONAL SAFETY

## Safely Operate Equipment

Do not operate equipment until you are trained by a qualified operator in its use and capabilities.

See your carrier's manual for these instructions.

- ✓ Operate only from the operator's seat. Check the seat belt daily and replace if frayed or damaged.
- ✓ Do not operate this or any other equipment under the influence of drugs or alcohol. If you are taking prescription medication or over-the-counter drugs ask your medical provider whether you can safely operate equipment.
- ✓ Never leave equipment unattended with the engine running or with the attachment in a raised position. Apply the brakes before exiting the equipment.
- ✓ Do not exceed the lifting capacity of your carrier.
- ✓ Avoid conditions that can lead to tipping. The carrier can tip when operated on hills, ridges, banks and slopes. Avoid operating across a slope which could cause the carrier to overturn.
- ✓ Reduce speed when driving over rough terrain, on a slope, or when turning to avoid overturning the carrier.
- ✓ Never use the attachment as a work platform or personnel carrier.
- ✓ Keep all step plates, grab bars, pedals and controls free of dirt, grease, debris and oil.
- ✓ Never allow anyone to be around the equipment when it is operating.
- ✓ Do not operate poorly maintained or otherwise faulty equipment. Inform the proper authority and DO NOT resume operation until the problem has been fixed.
- ✓ Do not alter or remove any safety features.
- ✓ Know your work site safety rules as well as traffic rules and flow. When in doubt on any safety issue, contact your supervisor or safety coordinator for an explanation.
- ✓ A heavy load can cause equipment instability. Use extreme care during travel. Slow down on turns and watch out for bumps. The equipment may need additional counter-weights to counterbalance the weight of the attachment.



# OPERATIONAL SAFETY

## Transporting the Attachment

- ✓ Travel only with the attachment in a safe transport position to prevent uncontrolled movement. Drive slowly over rough ground and on slopes.
- ✓ When driving on public roads use safety lights, reflectors, Slow Moving Vehicle signs, etc., to prevent accidents. Check local government regulations that may affect you.
- ✓ Do not drive close to ditches, excavations, etc., as cave-in could result.
- ✓ Do not smoke when refueling the prime mover. Allow room in the fuel tank for expansion. Wipe up any spilled fuel. Secure cap tightly when done.

## Equipment Condition

Never operate poorly maintained equipment. When maintenance is required, repair or replace parts immediately.



Serious injury or death could result if warnings or instructions regarding working overhead are not followed properly.

## Working Overhead

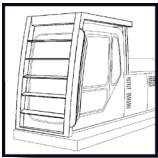

Avoid handling material overhead whenever possible. Safety glass and wire mesh cab guarding must be installed to protect the operator from flying debris that may be created during handling. Falling Object Protection Structures, or FOPS, are necessary for any application where material is to be handled overhead.



Serious injury or death will result if warnings or instructions regarding power lines are not followed properly.

## Power Lines

Do not operate the machine near energized power lines. All local, state/provincial and federal regulations must be met before approaching power lines, overhead or underground cables, or power sources of any kind with any part of the carrier or attachment. Always contact the appropriate utility when operating near power lines. The lines should be moved, insulated, disconnected or de-energized and grounded before operating in the area.



Current in high voltage lines may arc some distance from the wire to a nearby ground. Keep all parts of the machine at least 50 feet (16m) away from power lines.

## OPERATIONAL SAFETY



### WARNING

Serious injury or death could result if warnings or instructions regarding hydraulic fluid pressure are not followed properly.

#### Use Care with Hydraulic Fluid Pressure

Hydraulic fluid under pressure can penetrate the skin and cause serious injury or death. Hydraulic leaks under pressure may not be visible.

- ✓ Keep unprotected body parts, such as face, eyes and arms as far away as possible from a suspected leak. Flesh injected with hydraulic fluid may develop gangrene or other permanent injuries.
- ✓ If injured by injected fluid see a doctor immediately.
- ✓ Wear safety glasses and protective clothing and use a piece of cardboard or wood when searching for hydraulic leaks.

**Do Not Use Your Hands!**  
**See illustration below.**

- ✓ Hydraulic oil becomes hot during operation. Do not let hydraulic oil or components contact skin, as it could cause severe burns. Allow hydraulic components to cool before working on them. Use appropriate protective clothing and safety equipment. If burned, seek immediate medical attention.

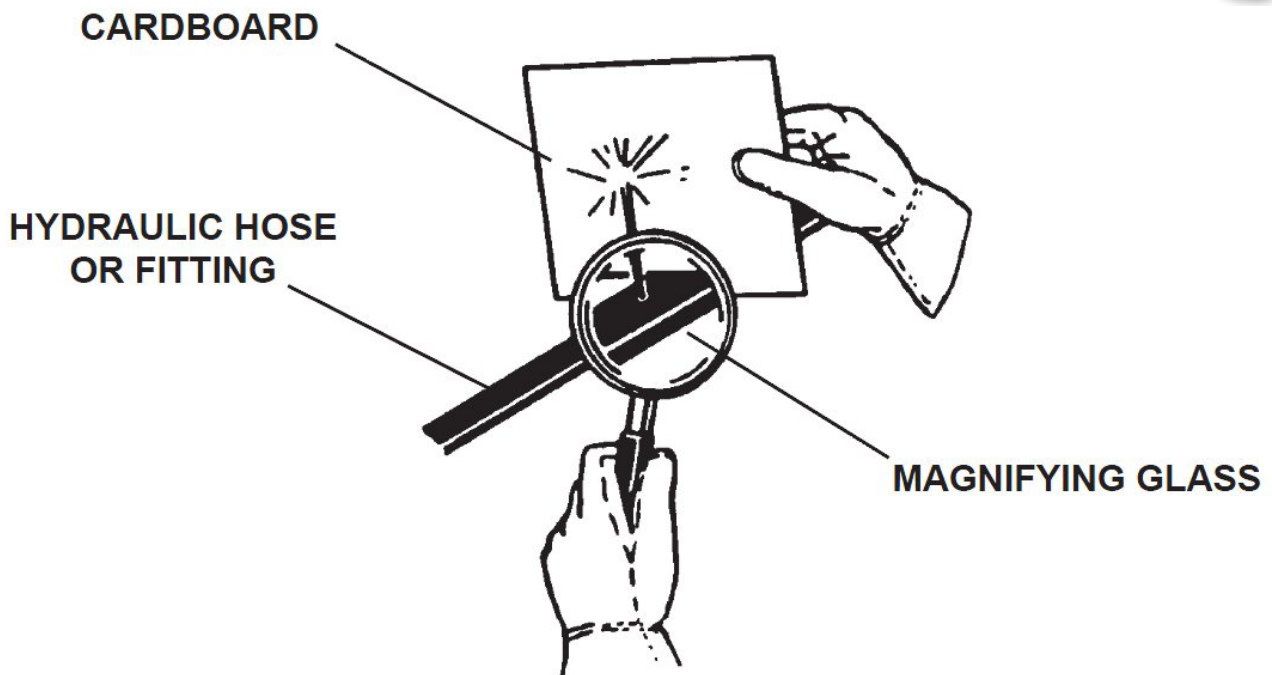

## OPERATIONAL SAFETY

### Prioritized Oil Flow

Equipment operators must ensure there is prioritized oil flow to the main valves in overhead operations or high reach conditions.

### Emergency Situations

Always be prepared for emergencies. Make sure a fire extinguisher is available. Be familiar with its operation. Make sure to inspect and service the fire extinguisher regularly. Make sure a first aid kit is readily available.



### Unsafe Conditions

Do not operate if an unsafe condition exists. Stop operation immediately, shut down the machine and report the unsafe condition to the proper authority. Equipment operation and maintenance practices directly affect your safety and the safety of those around you. Always use common sense while operating and be alert to unsafe conditions.

### Crystalline Silica Dust

It is recommended to use dust suppression, dust collection and if necessary, personal protective equipment during the operation of any attachment that may cause high levels of dust.



**DANGER**

Exposure to respirable crystalline silica dust along with other hazardous dusts may cause serious or fatal respiratory disease.

**IMPORTANT:** Concrete and masonry products contain silica sand. Quartz, which is a form of silica and the most common mineral in the Earth's crust, is associated with many types of rock.

Some activities that may have silica dust present in the air include demolition, sweeping, loading, sawing, hammering, drilling or planing of rock, concrete or masonry.

It is recommended to use dust suppression (such as water) or dust collection (such as a vacuum) along with personal protective equipment if necessary during the operation of any attachment that may cause high levels of silica dust.



### Prop. 65 Warning for California Residents



**WARNING**

This product may contain chemicals known to the State of California to cause cancer, birth defects, or other reproductive harm. For more information visit: [P65Warnings.ca.gov](http://P65Warnings.ca.gov)

## OPERATIONAL SAFETY



### **WARNING**

Using your Genesis attachment in unauthorized applications may create an unsafe situation and will void the warranty.

### **Process Material Safely**

- Do not process hardened steel material such as tool steel, railroad rail, axles, springs, machined parts or high-strength material. Hardened/high-strength material breaks, rather than shears, which may cause flying debris. It will also cause damaging decompression spikes to your Genesis attachment and base carrier hydraulic systems.
- Do not operate any functions of the carrier while cutting or crushing with your attachment, including boom and drive functions.
- Do not pull down structures with your Genesis attachment. Doing so may cause falling debris or material to break free and exceed the capacities of the carrier, causing a tipping hazard and rotation component failures.
- Do not use rotation to pry or break material. Doing so exerts high back-driving forces and spikes to the rotation circuit components that cannot be cushioned hydraulically. It may also cause motor failures. The rotator should only be used for positioning an attachment.
- Do not process pressurized containers unless the main valve has been removed and you are absolutely certain the container is empty.
- Do not process spring loaded brake chambers and automotive struts as the release of compressed springs is extremely dangerous. Nothing made of spring material or containing springs should be processed.

### **Lift the Load Safely**

- The hydraulic system has been preset and tested by your dealer. Do not alter hydraulic settings without consulting an authorized Genesis dealer or the Genesis Service Department. Doing so will void the warranty and may cause structural damage, accidents or tipping.
- Make sure the load is held securely in the jaws. Do not move a loaded attachment if load is loose or dangling. Make sure the load is pinched between the jaws – never cradle a load.
- For greater stability, knuckle the attachment to bring the load closer to the center of rotation (center of gravity) while lifting. Use extra caution during reaching to avoid tipping.

### **Place the Load Safely**

- Do not move the attachment, or anything held in the jaws, over people, equipment or buildings. Place the load gently. Do not throw or drop the contents.
- Operate the controls smoothly and gradually. Jerky controls are hazardous and may cause damage to the carrier.
- Avoid fire hazards. Keep the area clean. Remove all flammable materials from the area during any welding or heating process. Have a fire extinguisher nearby and know how to use it.
- Never substitute pins or bolts. Use factory supplied pins. Replace all bolts with the same size and grade. Failure to do so may cause serious injury or death.
- Use your Genesis attachment only as directed in this manual. Do not use the attachment to lift and move other objects. Doing so may cause instability and tipping.

# ATTACHMENT NOMENCLATURE

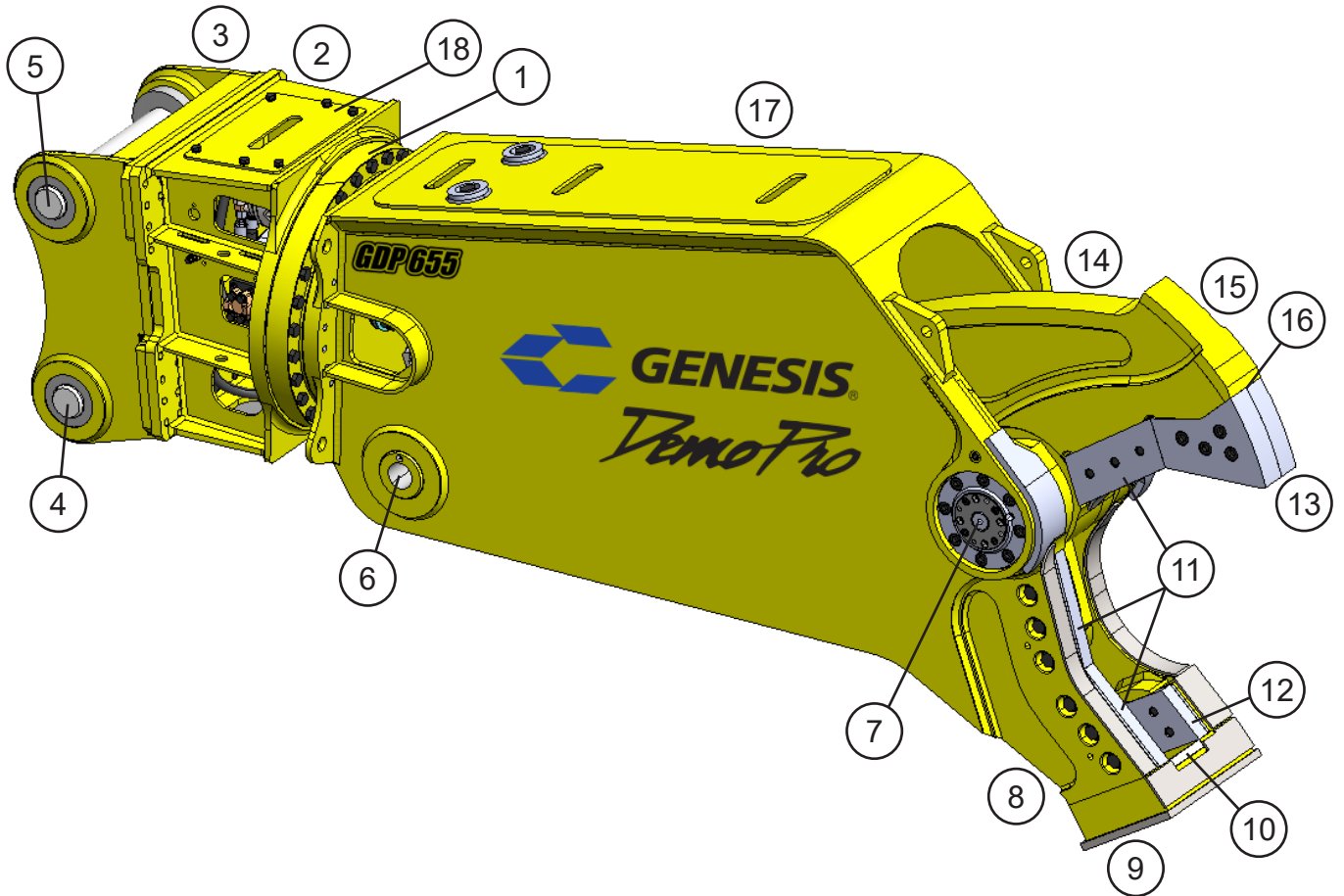

## ATTACHMENT NOMENCLATURE

1	<b>Slewing Ring</b>	Connects the attachment head to the attachment stick or body.
2	<b>Sub-Head</b>	Houses and protects the hydraulic components used for 360° rotation.
3	<b>Lugs</b>	Attachment serial number required for replacement parts.
4	<b>Stick Pin</b>	
5	<b>Bucket Cylinder Pin</b>	
6	<b>Rear Cylinder Pin</b>	Main cylinder
7	<b>Pivot Group</b>	Includes the end cap, tie rod, and tie rod nut.
8	<b>Lower Jaw</b>	
9	<b>Chin</b>	Maintain radii in razor blade pocket after build-up and hard-surfacing.
10	<b>Razor Blade</b>	NEVER insert shims behind.
11	<b>Cutting blades</b>	Upper and lower cutting blades. Only insert shims behind the lower, placing between the adjustment plate and blade when setting/adjusting blade gap.
12	<b>Guide blade</b>	Insert shims between the adjustment plate and blade when setting/adjusting blade gap. Note: From the operator's view, the left guide blade may or may not have an adjustment plate. If not, insert shim(s) directly against the back of the guide blade.
13	<b>Upper tip blades</b>	NEVER insert shims behind
14	<b>Upper Jaw</b>	NEVER shim blades in upper jaw.
15	<b>Rhino Horn</b>	Replaceable wear surface. Protects upper tips, provides "horn" to move material.
16	<b>Tang</b>	Parent material underneath and between upper tip blades.
17	<b>Access cover</b>	Access to hydraulic cylinder and regen block.
18	<b>Access cover</b>	Access to hydraulic motor and rotation flow controls.

## ROTATION LOCK

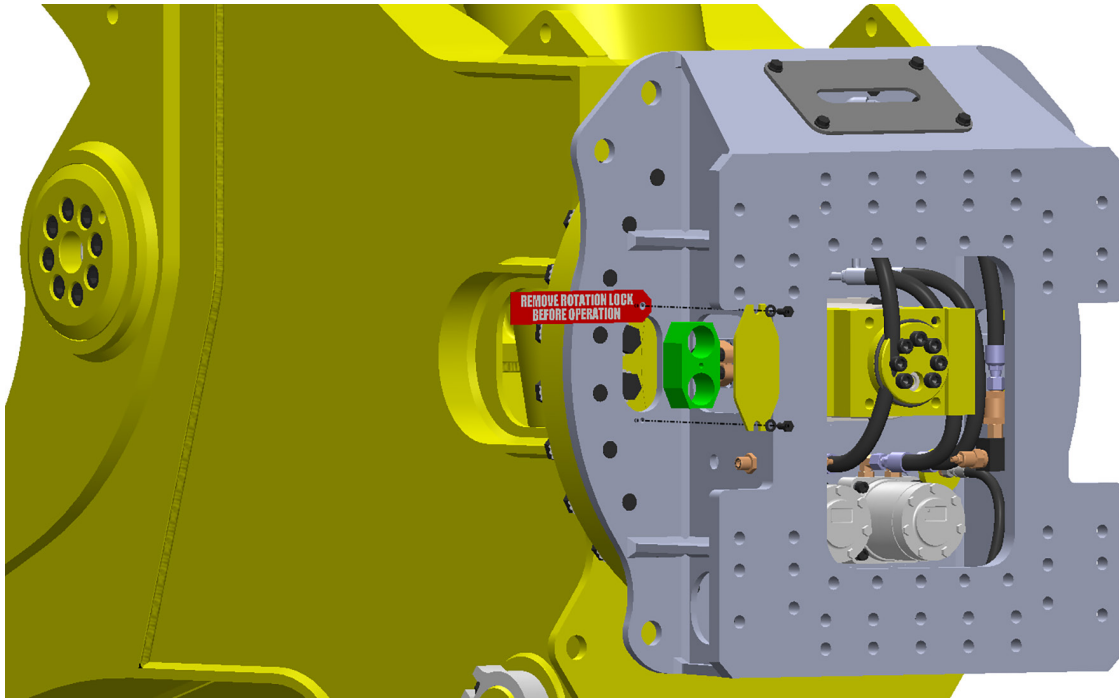

Rotation (transport) locks are installed at the factory to allow the bracket to be shipped with the mounting pins facing upward. This is beneficial to the end user when removing the attachment from the truck and mounting it to the excavator.

**Rotation locks MUST be removed before operating the attachment to prevent rotation system damage.**

The rotation locks are located inside the small bolt covers for the slewing ring and marked with a red flag labeled “REMOVE ROTATION LOCK BEFORE OPERATION”. The cover bolt can be threaded into the rotation lock for removal.

There are TWO locks in every attachment, one on either side of the bracket. In some cases, one of the port blocks may need to be removed to access the rotation lock. The rotation locks and red flags should be saved for use during future transportation.

# LIFTING LUG LOCATIONS

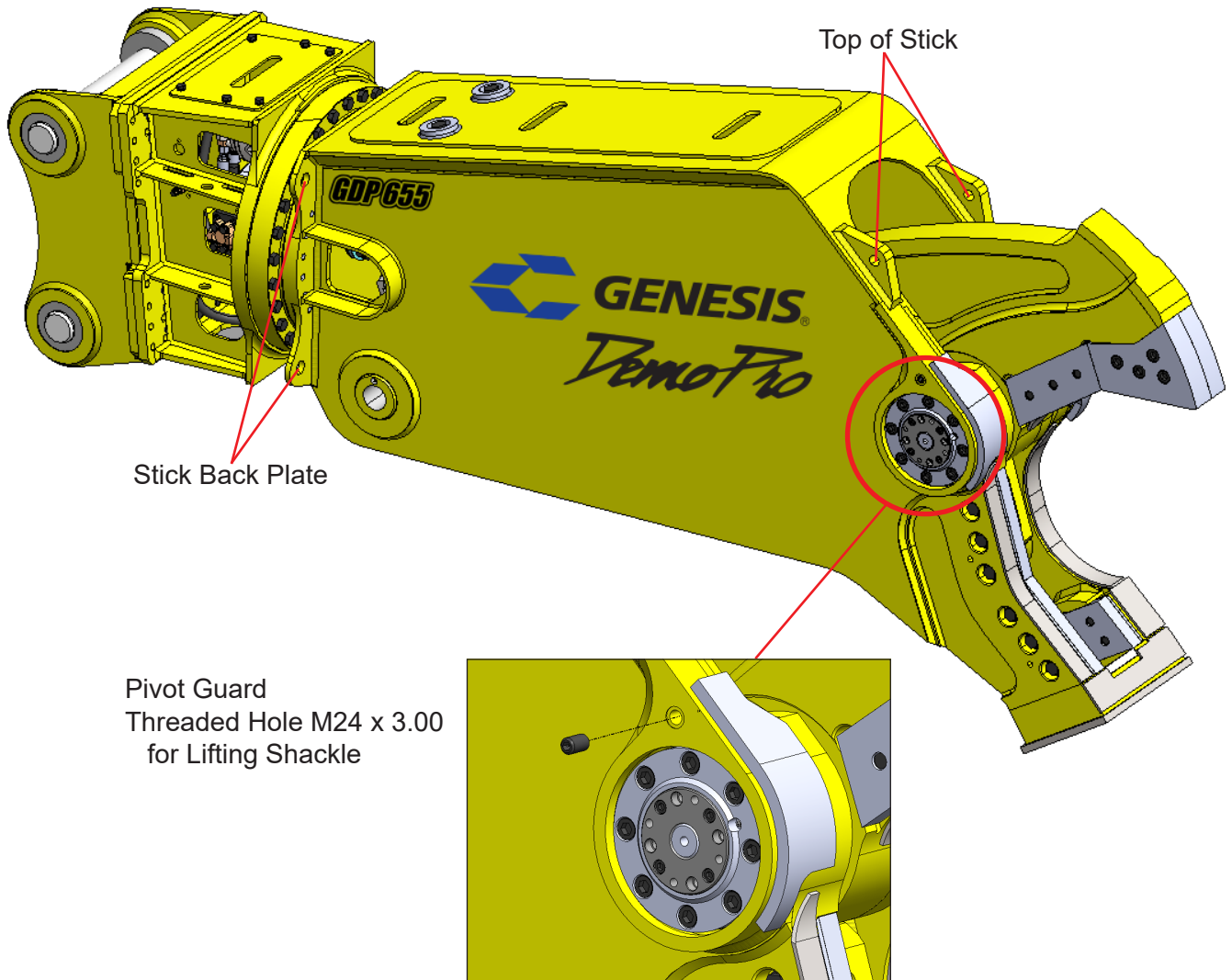

## ATTACHMENT INSTALLATION



### WARNING

Be sure hydraulic pressure is relieved before disconnecting hydraulic fittings. Remove necessary fittings SLOWLY.

The attachment is usually shipped in an upright position. Extreme care must be used when inverting the attachment for installation.

Follow the excavator OEM's removal and safety instructions to remove the bucket or other stick attachments.

Position the attachment upside down on flat, solid ground. Blocking may be required to raise the mounting bracket into proper position.

Track the excavator to the attachment with the jaws facing the operator. Lift the excavator stick over the attachment, carefully positioning the stick tip connection with the attachment mounting main pivot bore. Pin the excavator stick to the attachment.

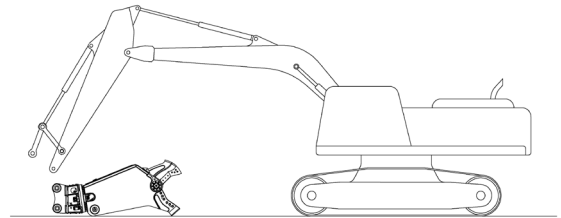

Slowly raise the boom to lift the attachment, allowing the cylinder pivot connection to come within range of the excavator cylinder stroke.

Extend the excavator cylinder until the power link bore lines up with the cylinder pivot connection. Pin the excavator cylinder to the attachment.

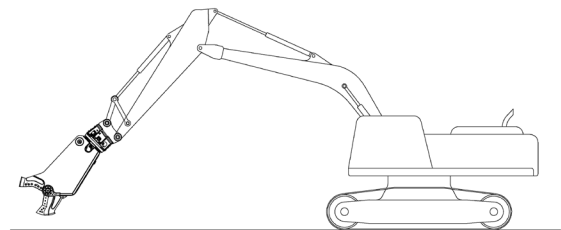

Crowd and extend the attachment, checking closely to make sure there is no interference between the bracket and hard lines. Also check for interference between the cylinder and boom/stick.

Install excavator hydraulic hoses, supply and return, from the stick tip to the attachment manifold blocks.

The stick and bucket circuits are oriented as to rod and bore sides of their respective cylinders. Be sure to connect rod-to-rod and bore-to-bore when connecting a circuit to the attachment. When these are reversed, extra pressure is needed to open the jaw, which pulls down the engine, de-strokes the pumps, increases jaw cycle time, creates high oil temperature and burns more fuel.

The attachment must be vertical before putting oil into it or an air lock in the regen valve may prevent the jaw from opening.

**Note: Genesis' standard pin material is Induction Hardened Chrome (IHC), which is to be used for all direct pin 2<sup>nd</sup> and 3<sup>rd</sup> member mounting. To avoid risk of pin failure when using a pin grabbing coupler, the standard IHC pins must be replaced with a heat-treated pin material from Genesis.**

## ROTATOR INSTALLATION

The rotator requires a ½" minimum case-drain line with a minimum working pressure rating of 250 PSI. **Run the case-drain line from the rotation head of the attachment to a dedicated filter on the excavator, plumbed directly into the main section of the hydraulic tank. Do not plumb to the return side of the tank.**

The maximum case-drain pressure measured at the motor while attempting to rotate the attachment stalled on the ground is 40 PSI. Case-drain pressures will rise during cold weather operation.

Use the correct fittings. Secure the case-drain line to the excavator stick.

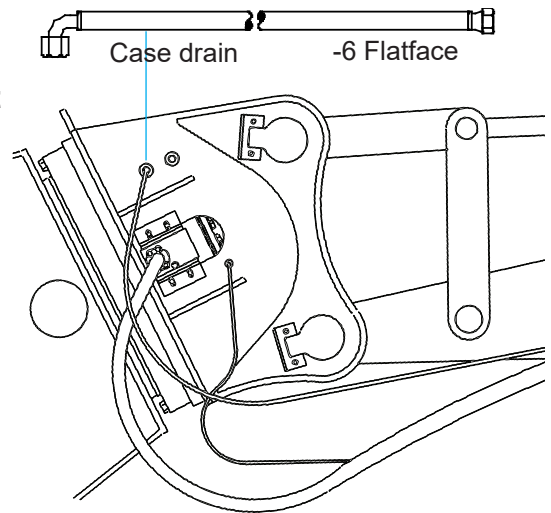

### NOTICE

**Do not plumb the case-drain into the main return system or into any other existing case drain or return circuit. Plumb only to the hydraulic tank.**

### Foot Switch Installation

Install the foot switch in the excavator and connect with electrical harness.

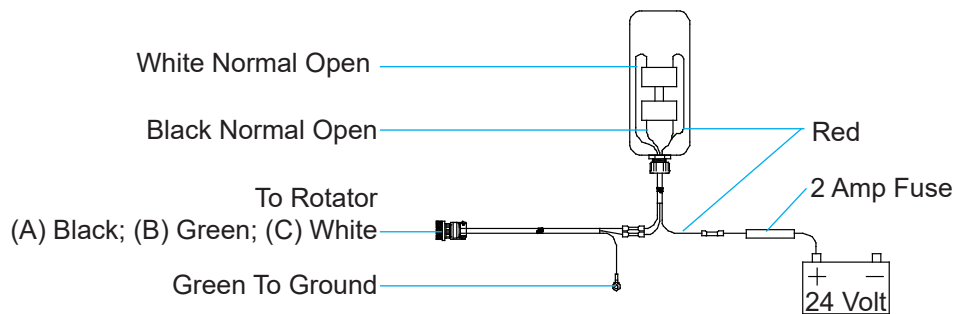

The rotator requires an additional hydraulic circuit. One of the several available options has been supplied with the attachment. These diagrams show the installation of the additional circuit. Refer to the Hydraulic/Rotation Maintenance section of this manual for valve descriptions, functions and settings.

# ROTATOR INSTALLATION

## Rotation Circuit - Radial Piston/Gerotor Motor

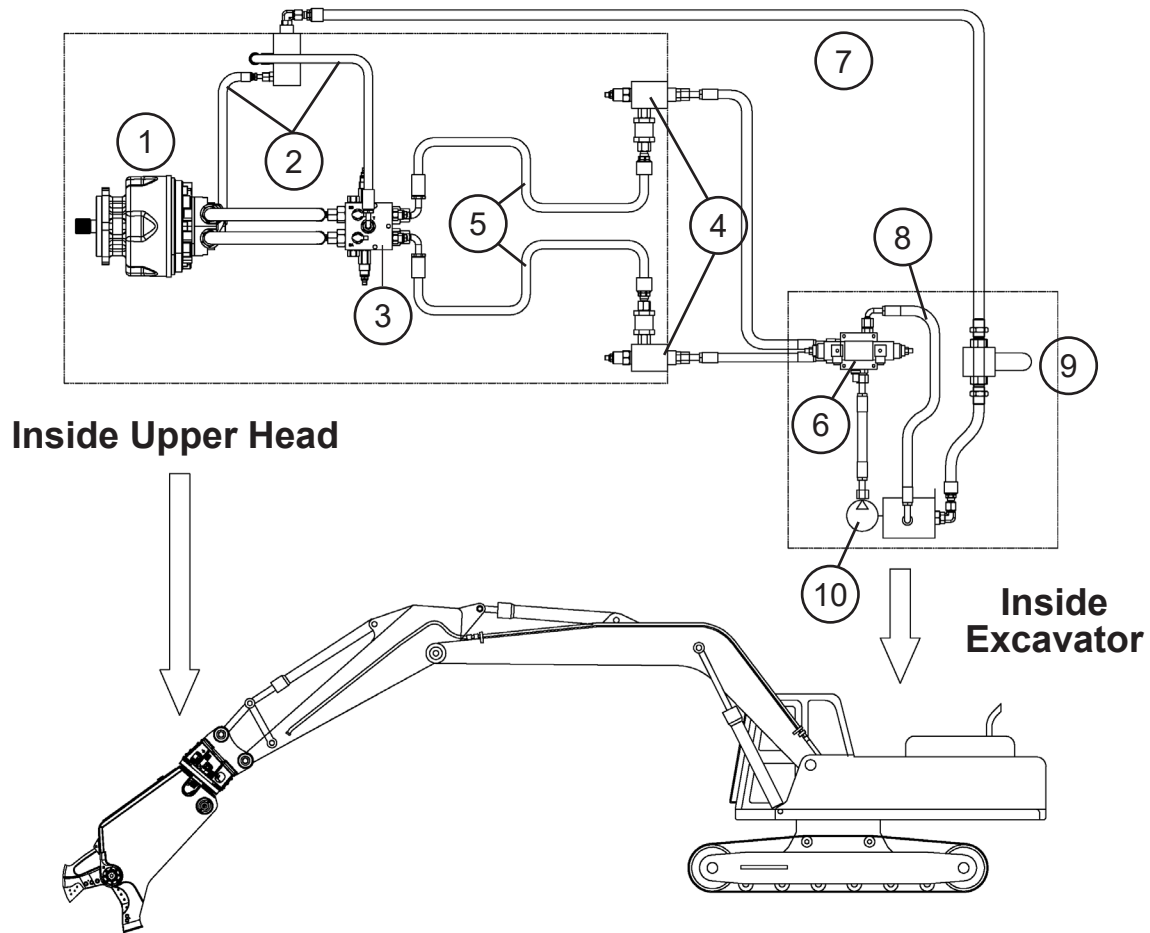

1	<b>Hydraulic Motor</b>	
2	<b>Motor Case Drain</b>	Do not exceed 40 PSI while operating.
3	<b>Motion Control Valve</b>	
4	<b>Flow Controls</b>	
5	<b>Rotate Work Lines</b>	Use ½" 3,000 PSI rated hose.
6	<b>Rotation Valve</b>	3 position, tandem center, spring centered, with anti-cavitation checks. Port relief settings - see Rotation Valve Input, page 50.
7	<b>Case Drain</b>	Use minimum ½" 250 PSI rated hose (to dedicated filter). <b>Do not plumb the existing case-drain into the main return system or into any other existing case-drain or return circuit. Plumb only to the hydraulic tank.</b>
8	<b>Rotate Return Line</b>	Use minimum ½" 2,000 PSI rate hose (to return filter).
9	<b>Dedicated Filter</b>	Dedicated to case drain line only - 10 micron
10	<b>Gear Pump</b>	

# ROTATOR INSTALLATION

## Rotation Circuit - Auxiliary Valve on Machine

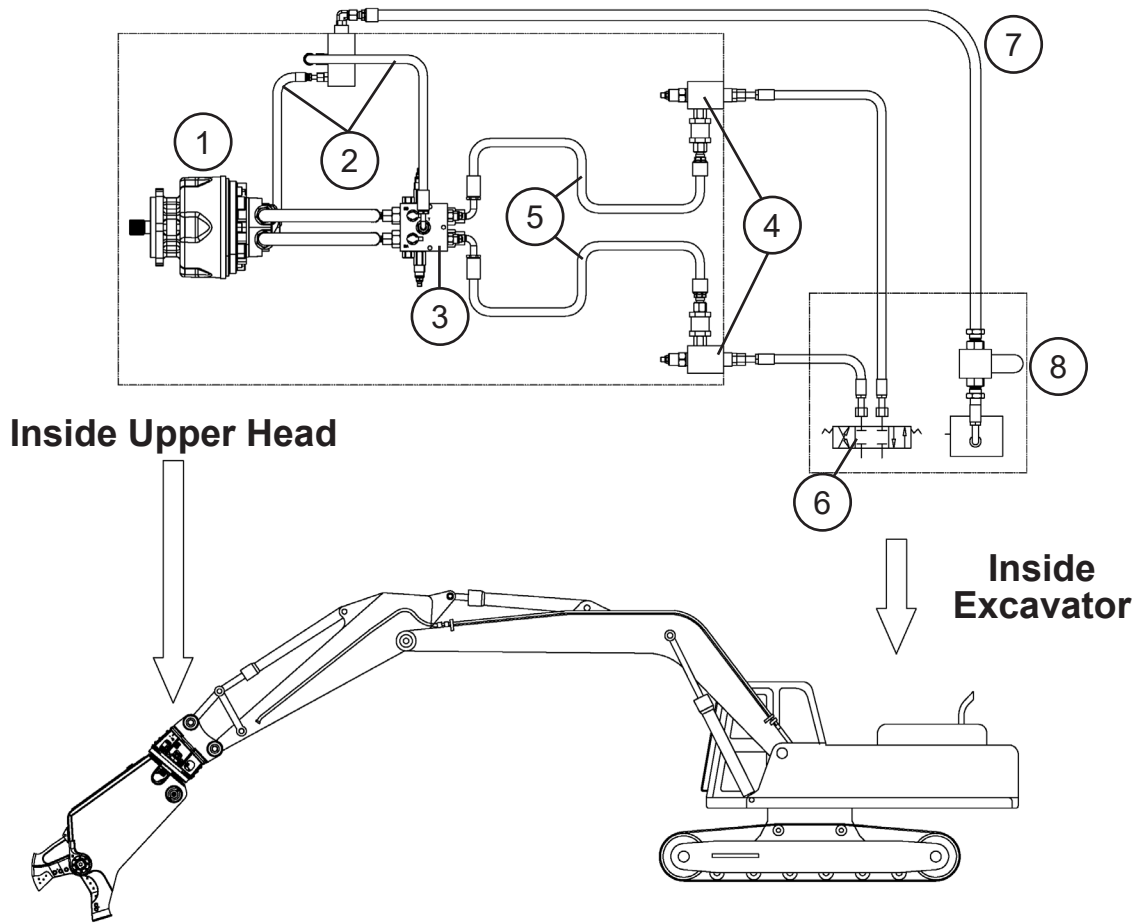

1	<b>Hydraulic Motor</b>	
2	<b>Motor Case Drain</b>	Do not exceed 40 PSI while operating.
3	<b>Motion Control Valve</b>	
4	<b>Flow Controls</b>	
5	<b>Rotate Work Lines</b>	Use ½" 3,000 PSI rated hose.
6	<b>Auxiliary Valve</b>	3 position, tandem center, spring centered, with anti-cavitation checks. Port relief settings - see Rotation Valve Input, page 50.
7	<b>Case Drain</b>	Use minimum ½" 250 PSI rated hose (to dedicated filter). <b>Do not plumb the existing case-drain into the main return system or into any other existing case-drain or return circuit. Plumb only to the hydraulic tank.</b>
8	<b>Dedicated Filter</b>	Dedicated to case drain line only - 10 micron

## HYDRAULIC START-UP

Genesis attachments are designed to operate under full excavator pressure or up to 5500 PSI. Due to these high pressures, it is important that air is bled from the attachment cylinder after installation. Failure to follow these procedures could result in cylinder seal damage and/or excavator hydraulic system damage.

### Start-up Procedure

- ✓ Check the excavator hydraulic tank for proper fluid level.
- ✓ Excavator oil should be warmed up before hooking up attachment lines in cold weather. If oil is cold, air from the cylinder will be pushed into the oil tank, causing oil to foam. This problem takes hours to correct, and it may cause pump cavitation.
- ✓ Follow the OEM procedures for starting and warming the excavator hydraulic system. Do not operate the attachment circuit during the warm-up period.
- ✓ After the excavator has reached normal operating temperature, set the engine to idle speed.
- ✓ Attachment must be vertical. Do not allow the tank to run low - have someone watch the oil gauge.
- ✓ Slowly fill the bore end of the attachment cylinder to partially close the jaws.

### **NOTICE**

Do not fully extend or retract attachment cylinder with the first cycles.

Slowly fill the rod end of the attachment cylinder to open the jaws. Use partial strokes extending and retracting, slowly working to full strokes.

Stop and check the excavator hydraulic fluid level again to be sure there is still sufficient fluid. Service as required. Note: hydraulic fluid level should be checked with the attachment jaws open (cylinder retracted).

Cycle the attachment jaws five or six strokes before increasing to full operating pressure.

## GENERAL OPERATION INSTRUCTIONS

Follow all rules and procedures outlined in the Operational Safety section of this manual.

Use the attachment only as intended, in approved applications, as set forth in this manual.

Do not allow attachment, exposed cylinder rod or hoses to come into contact with any obstacles, buildings or the excavator.

The attachment is not intended to crush or break objects or structures by swinging or dropping the attachment.

### **Start-up**

During initial operation and any time jaw maintenance has been performed, process thin and lighter material first to work-harden wear areas, developing a harder, more durable edge. This is also the most effective time to process materials such as sheet metal or wire. The new or repaired edges will cut more efficiently and be less likely to jam material between the blades.

### **NOTICE**

When operating in temperatures below freezing, it is also important to process light materials first. This allows the attachment's structural material to warm-up, preventing thermal cracking.

### **Efficient and Productive Operation**

Operators should become accustomed to performing work in the most proficient manner possible.

When cutting, build up and cut out of small piles, keeping the surfaces of the attachment chin plate and upper jaw out of the dirt as much as possible. Dirt is much more abrasive than steel and needlessly increases build-up and hard-surfacing time and intervals.

It also helps to give yourself enough room to keep out of the way of other personnel and machines. Material should be picked from a pile and swung to the side and cut in a new area. This prevents redundant cutting of the same pieces and allows for the newly prepared material to be loaded out with another material handling machine.

Material processing areas should be as close as safely possible to the location for loading materials for transportation. Less time spent processing, loading and transporting materials greatly affects operational costs and productivity and dramatically reduces man hours, fuel costs and wear on equipment.

Operators should develop the habit of assessing materials to be processed and visualizing a starting and finishing point to use the fewest cuts possible. Excessive moving, positioning and handling cost time and money. Bringing the jaws to full open, when only partial jaw open is needed for a cut, wastes time and fuel, slows other excavator functions as well as causes needless wear to hydraulic components, hoses and o-rings. More efficient processing will extend the life of the attachment.

## COMMON OPERATIONAL CONCERNS

### **Cutting Larger Materials**

When cutting larger materials the attachment jaw stalls just before cutting.

Suspend the material on the prepared pile, open the jaw and position the material as close to the throat as possible. Without pushing down on the material with excavator force, rapidly close the jaw on the material. Using the speed of regeneration can improve performance when cutting larger materials.

### **Chatter While Cutting**

If the attachment starts to chatter while cutting, back out of the cut and reposition at a different spot.

Chattering is an indication that material is jamming between the piercing blades and guide blades or between the upper and lower cutting blades. This indicates that blade maintenance needs to be performed immediately. Worn blades and improper blade gaps are usually the cause.

Insufficient piercing blade gaps will also cause this, as the blades and parent material of the jaws are subject to thermal expansion from cutting friction. The tighter the blades run, the hotter they get and the more they expand. Piercing blades and guide blades are the most susceptible to this and will show blue streaking on their corresponding faces. In some cases, they will get so hot that surface cracks and spidering occur. As this happens, it will spread the lower jaw and increase gaps between the primary and secondary blades, causing thin material to jam between them.

Another key area to watch is the opening between the guide blades. Be aware of material that may get into this opening before the piercing blade moves into this space, as it will be wedged between the piercing blades and guide blades.

Most jamming conditions can be prevented if the operator pays attention to the sound and vibration that is associated with a jam. Remember that because of the rod-to-bore ratios of displacement on the attachment's hydraulic cylinder piston, the attachment has half the force on jaw open compared to jaw close. So if the attachment is jamming while closing, it won't have enough retract force to open.

# GENERAL OPERATION INSTRUCTIONS

## Pulling / Back-Tracking

While pulling down structures is not recommended, it may, at times, be necessary to pull on objects to remove them from a pile or better position pieces to be cut.

To minimize stress in the attachment body and damage to the pivot components, it is best to keep the attachment in line with the boom and stick.

If the attachment needs to be perpendicular to the boom and stick, the blade side of the attachment should face **TOWARD** the operator.

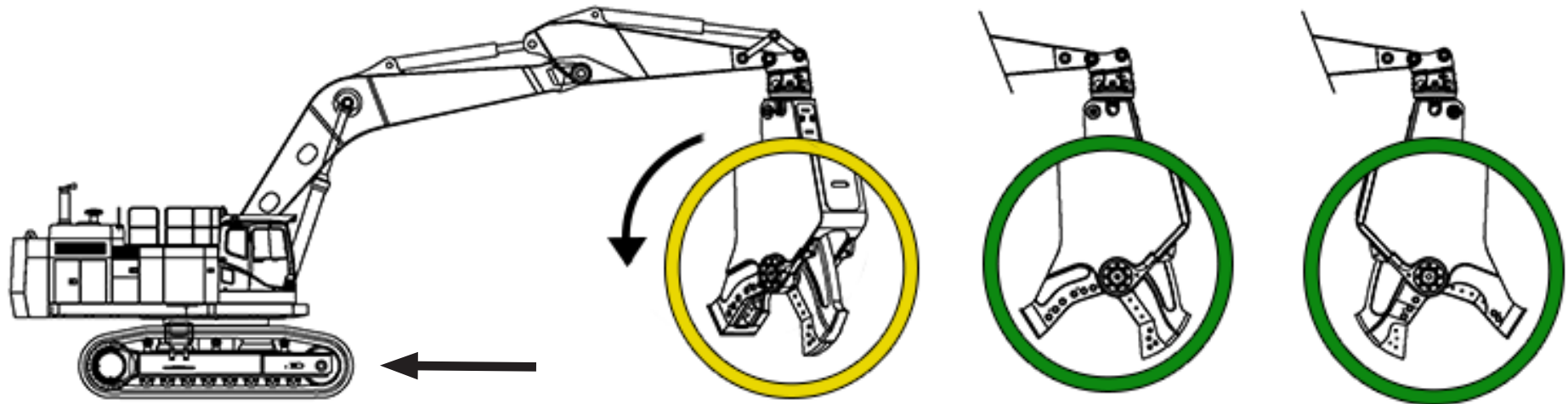

**OK**

**Blades Toward  
the Operator**

**Best**

**Attachment is In Line with  
the Excavator Boom and  
Stick**

**Best**

# GENERAL OPERATION INSTRUCTIONS

## Pushing / Tracking Forward

When pushing material, it is best to keep the attachment in line with the boom and stick.

If the attachment needs to be perpendicular to the boom and stick, the blade side of the attachment should face **AWAY** from the operator.

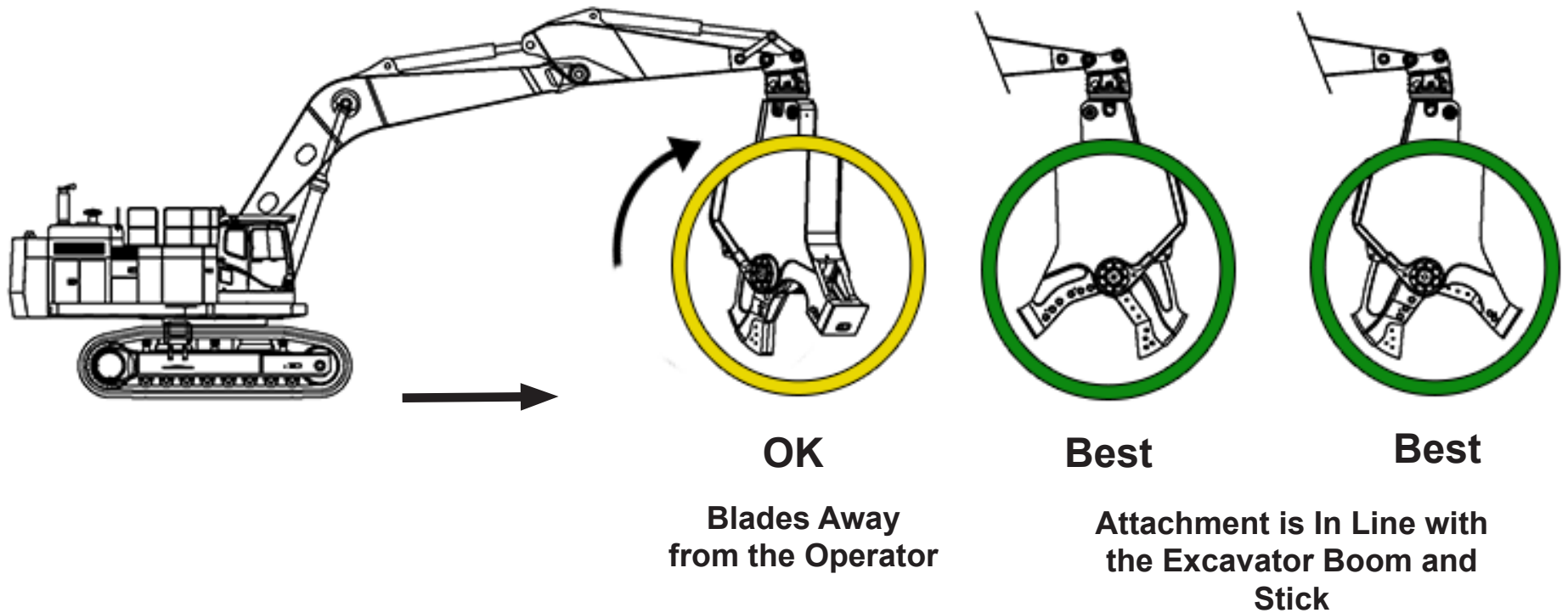

## GENERAL OPERATION INSTRUCTIONS

### Cutting in a Pile

Material that is stacked in a pile has a resistance to movement that causes undo stress in the attachment body when you try to cut it. This stress occurs in **both straight and rotating units** because the attachment will work to align itself with the material.

It is best to cut material that freely moves so work to free pieces or cut from the top of the pile down.

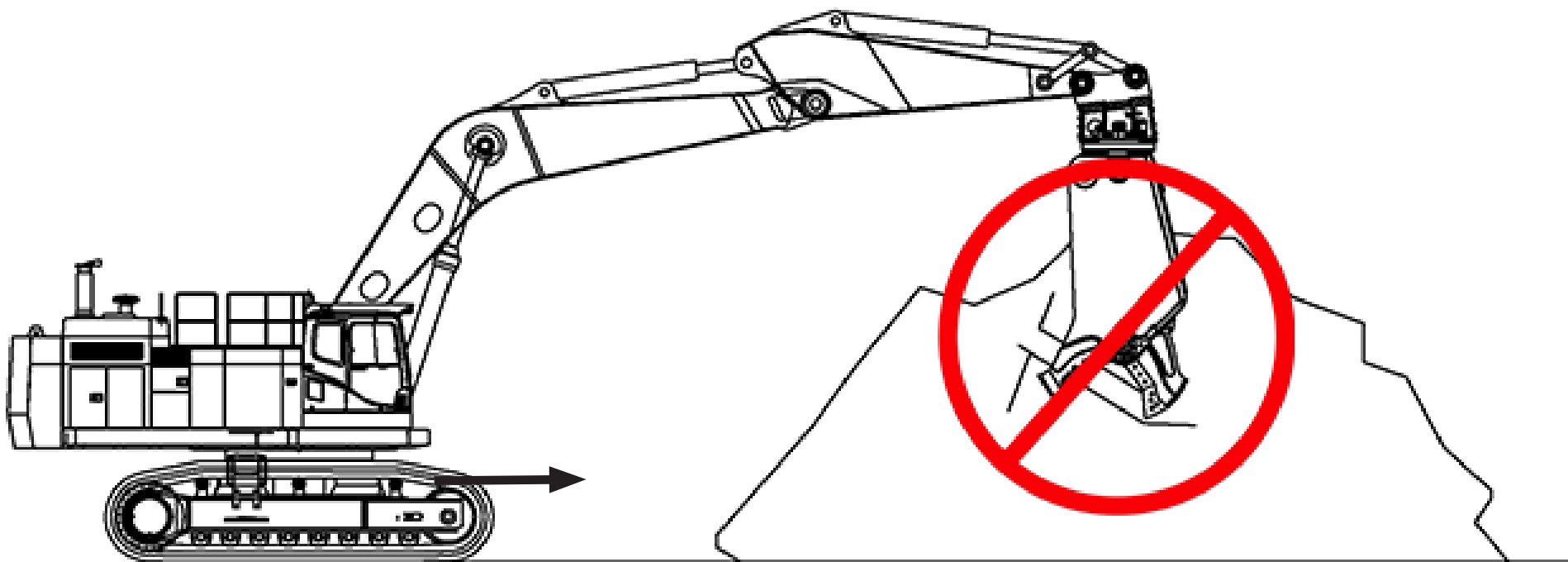

## MAINTENANCE SAFETY

Only trained and authorized persons should perform maintenance on the attachment. To be qualified, you must understand the instructions in this manual, have training, and know the safety rules and regulations of the job site.

Do not alter the physical, mechanical or hydraulic operation of the attachment. Doing so may cause a dangerous situation for yourself and those around you and will void the warranty.

Do not attempt repairs you do not understand. If any questions arise regarding a safety or maintenance procedure, contact Genesis or your Genesis dealer.

Read this entire manual. All personnel must understand the maintenance and safety procedures.

Use factory authorized parts. The use of unauthorized parts may compromise safety, performance and durability of the attachment and may void the warranty.

Follow the daily checklist and maintenance schedules in this manual. Extreme conditions may dictate shorter maintenance intervals.

Do not exceed bolt torque specifications. See the Genesis Fastener Manual.

Do not weld on structural components without consulting Genesis. Doing so may cause structural failure and void the warranty.

Do not operate an attachment without the case-drain line properly installed if the attachment uses a rotation system that requires a case drain. Doing so will cause immediate failure of the rotate motor.

Do not work on the attachment before ensuring it will not move. Completely lower the boom to the ground or a rest position and relieve hydraulic pressure.

Never operate poorly maintained equipment. When maintenance is required, repair or replace parts immediately.

Do not operate under unsafe conditions. If an unsafe condition arises during operation, immediately shut down the equipment and report the situation to the proper authority.

## MAINTENANCE SAFETY

Do not work on any hydraulic lines or components while they are pressurized. Escaping hydraulic fluid can penetrate the skin, causing serious injury or death. Relieve pressure before performing maintenance. Keep hands and body parts away from pin holes and nozzles, which eject fluids under high pressure. Use a piece of cardboard to search for leaks.



If fluid is injected into the skin, seek medical assistance immediately from a doctor familiar with this type of injury.

### NOTICE

See “Use Care with Hydraulic Fluid Pressure”, page 13.

Hydraulic oil becomes hot during operation. Do not let hydraulic oil or components contact skin, as it could cause severe burns. Allow hydraulic components to cool before working on them. Use protective clothing and safety equipment.



Remove paint before welding or heating. Hazardous fumes/dust can be generated when paint is heated by welding, soldering or using a torch. Do all work outside or in a well ventilated area and dispose of paint and solvent properly.

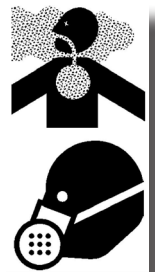

When sanding or grinding paint, avoid breathing the dust. Wear an approved respirator. If you use solvent or paint stripper, remove stripper with soap and water before welding. Remove solvent or paint stripper containers and other flammable materials from area. Allow fumes to disperse at least 15 minutes before welding or heating.

Avoid fire hazards. Keep the area clean. Remove all flammable materials from the area during any welding or heating process. Have a fire extinguisher nearby and know how to use it.



Never substitute pins or bolts. Use factory supplied pins. Replace all bolts with the same size and grade. Failure to do so may cause serious injury or death.

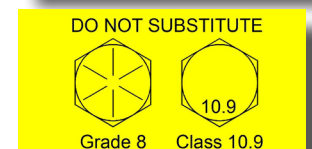

## MAINTENANCE SCHEDULE

Performing scheduled maintenance will promote safe, reliable operation of your attachment. Inspect and grease components every eight hours of operation, as indicated in the following checklist. Use maintenance procedures described in this manual. If you are not able to safely and competently perform these procedures, have a Genesis dealer perform them.

After the first **80 hours** of operation, check all bolts, including slewing ring bolts.

### NOTICE

Extreme operating conditions may require shortened maintenance intervals.

Operating the attachment with excessively worn blades, blade gaps or main bearings could lead to premature cylinder failure. Excessive deflection of the upper jaw from these conditions will transfer side loading forces to the cylinder piston and barrel, which causes undue pressure on the wear bands of the piston, potentially resulting in cylinder failure.

Pounding the upper jaw lever arm or cylinder clevis on the ground or a hard object to clear a material jam can cause high pressure hydraulic spikes to the attachment and excavator which can damage the hydraulic system components. These spikes can damage the cylinder piston seals, which will allow oil to bypass and wash out the piston wear bands, resulting in premature and possibly catastrophic system failures.

### Scheduled Maintenance

- ✓ Replace regeneration valve components every 4000 hours.
- ✓ Reseal cylinder at 2 years or 4000 hours, whichever occurs first, the first time; 18 months or 3000 hours for all following reseals. In severe-duty applications or if operating the attachment more than 10 hours per day, reduce these intervals.
- ✓ Reseal swivel every 2 years or at the time of cylinder resealing.

# MAINTENANCE SCHEDULE

## **Four-Hour Checklist**

Mid-shift, perform a brief visual check for hydraulic leaks, blade damage, and loose or missing bolts. A more thorough inspection, to be performed at the end of each shift, is described below on the eight-hour checklist.

### **Grease:**

- Attachment cylinder - end of pin
- Attachment cylinder rod
- AutoGuide at fitting and smear grease on contact surface of upper jaw
- Main shaft/pivot, both sides

Grease all locations until grease extrusion is visible with jaw open and closed.

## **Eight-Hour Checklist**

### **Inspect:**

- Bolts - check for loose bolts, replace if damaged
- Fittings and hoses for damage or leaks
- Bracket pivot for wear and pin retainers
- Cylinder pivot for wear and pin retainers
- Entire attachment for cracks (visual check)

### **Grease:**

- Bracket pivot
- Bracket cylinder
- Bearing slewing (four locations)
- All points listed in 4-hour checklist

Grease all locations until grease extrusion is visible.

### **Jaws and Blades:**

- Check blade gaps\*
- Check blade edge radiuses\*
- Check for loose or damaged bolts, re-torquing loose bolts when cool
- Check AutoGuide and shim if needed
- Build-up and hard-surface as required
- Grind off any rolled-over or mushroomed blade edges
- Shear Jaw Armor® - build-up and hard-surface as needed

\* See Blade Maintenance information in this manual regarding maximum gap and radius for your specific attachment. Blade gaps should be checked and maintenance performed when the attachment has cooled to ambient temperature.

## LUBRICATION POINTS



Shut off excavator and disable hydraulics per OEM instructions before greasing.

For normal conditions above 32°F (0°C), use a lithium-based, premium grade 2 extreme-pressure grease. For temperatures below 32°F, use a grade 0 grease.

**Do not use grease containing Molybdenum (Moly).**

Genesis GLG-2® anti-wear, extreme-pressure lithium grease, PN 6302601, is recommended for all temperature conditions.

The jaws must be closed for access to all grease fittings. Grease all fittings every eight hours of operation (see eight-hour checklist).

After greasing the rotation bearing, rotate the attachment through two full rotations.

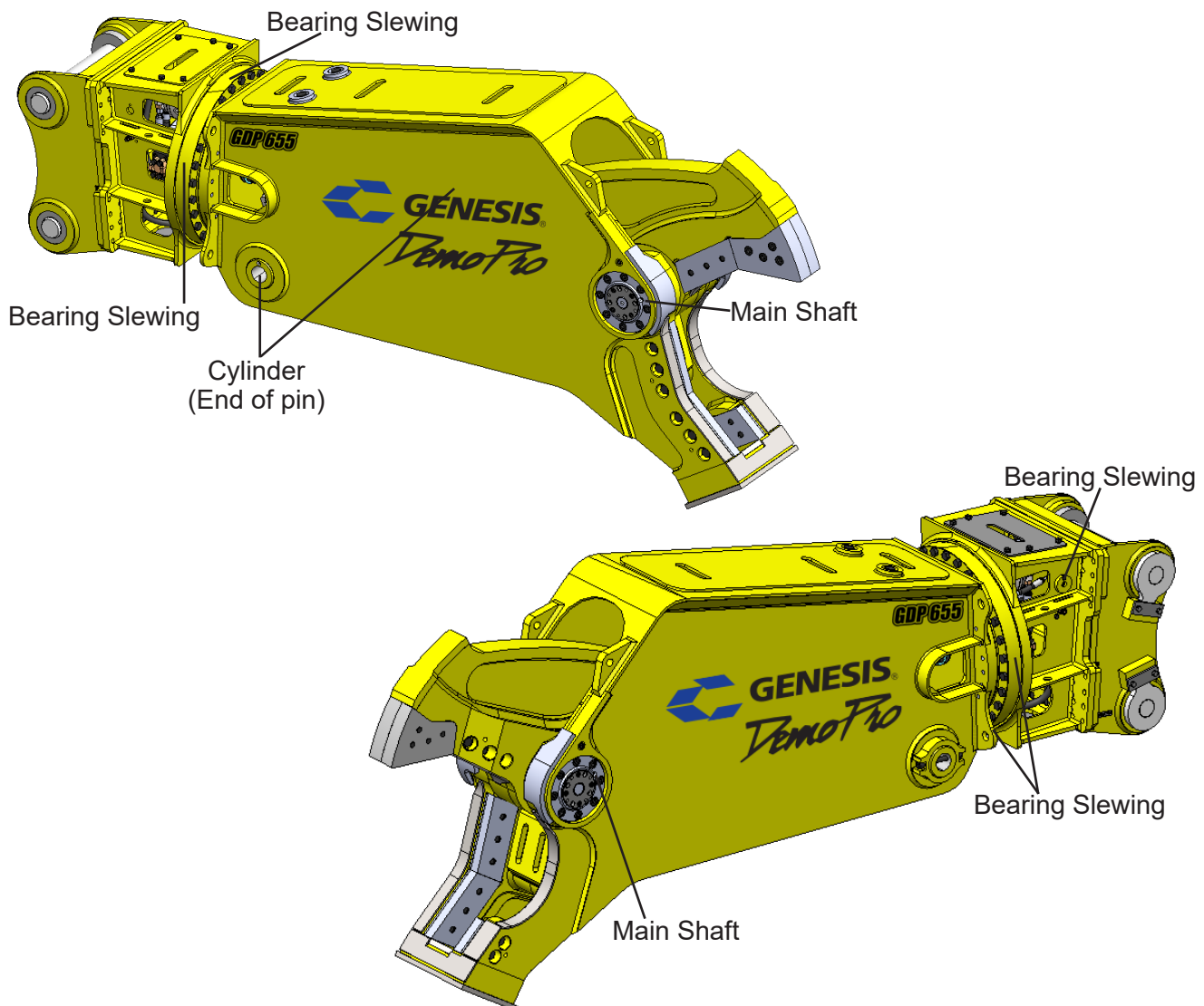

## **BOLT TORQUE SPECS**

**Bolt torque specs and thread treatment procedures can be found in the  
Genesis Fastener Manual.  
[genesisattachments.com/manuals](https://genesisattachments.com/manuals)**

## JAW AND BLADE MAINTENANCE

Blade and blade seat maintenance greatly affects performance. To maximize cutting performance and optimize replacement part life, follow this specific sequence of checks, adjustments and maintenance.

1. Guide Blade - rotate, shim to tolerance and replace when worn
2. Upper Left-hand Tip Blade - replace when worn
3. Blade Fuses - replace if worn, cracked or damaged
4. Upper Right-hand Tip Blade - replace when worn
5. Primary and Secondary Blades - rotate, shim to tolerance and replace when edges are worn. All three blades are identical.
6. Razor Blade - rotate to use four edges, then replace
7. Jaw hard-surfacing - build-up and hard-surface as needed.

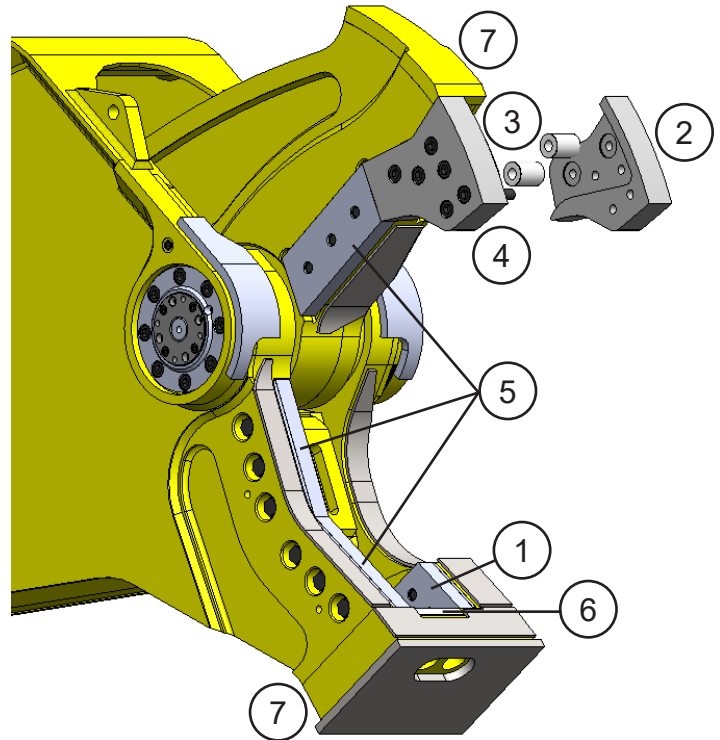

### **Blade Bolts**

Visually check for loose or broken bolts daily. Retorque loose bolts to the specifications listed in the Genesis Fastener Manual torque chart. Replace broken bolts.

# UPPER TIP BLADES

## Upper Tip Blades

Maintain tip blades to maximize productivity and safe operation. An excessive gap results in a great reduction in piercing and cutting efficiency and contributes to material jamming.

The front blades should be checked for wear daily. Replacement or rebuild should be performed every 40-80 hours depending on the application.

### **Use the following procedure to check for wear.**

1. Slowly close jaws until the piercing blades are flush with the top edge of the razor blade, or, if concrete tips are installed, until the upper blades pass the top edge of the razor blade.
2. Check gap with a tape measure. Acceptable gap is  $\frac{3}{8}$ " to  $\frac{3}{4}$ ".
3. Check the condition of the tip blades with a straight edge or square.
4. Check the profile along the blades.
5. Badly worn blades must be replaced. However, slightly worn blades may be squared up with a grinder and a square. This may be repeated until a maximum of  $\frac{1}{2}$ " of material is removed from the lower edge.
6. Typical use requires blade replacement at approximately 200 hours; heavy piercing requires replacement at approximately 40 hours. These are general guidelines only. Replace blades based on wear, not hours of operation.
7. Width of blades, top to bottom, may taper 0.060" (2 mm) total. Bottom edges may be worn to a maximum radius of  $\frac{3}{16}$ ".

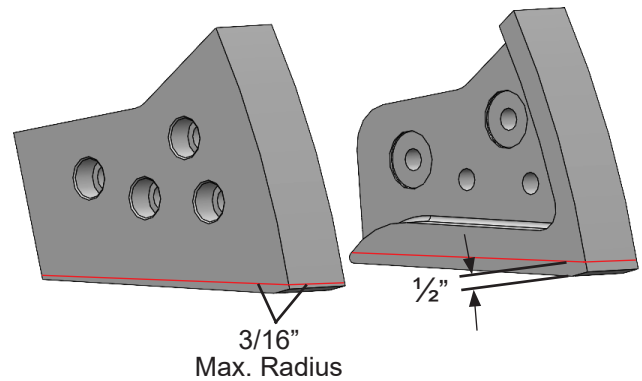
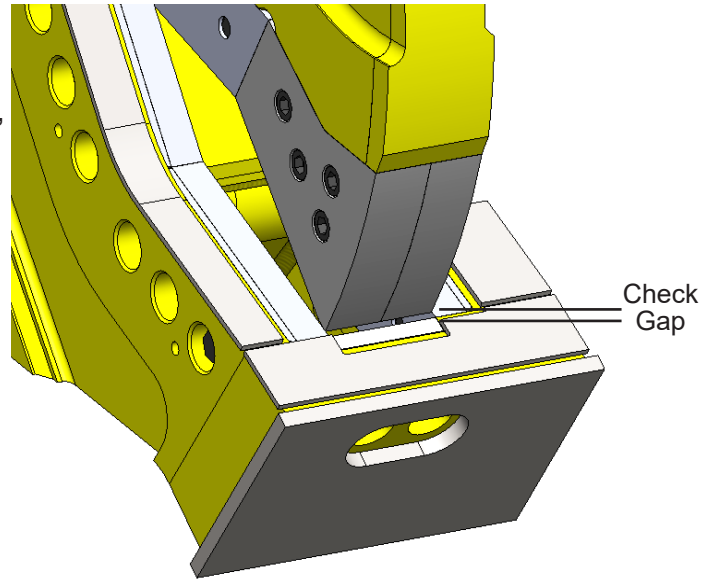

## Blade Fuse

The blade fuse is an important safeguard to the front blade, blade seat and blade bolts. The blade fuses must be inspected for damage any time the blades are removed for rebuild or replacement. If cracks are found or the fuse is deformed, it must be replaced.

## UPPER TIP BLADES

Tip blades must fit tightly in some areas while having clearance in others. Tip blades are made from the same material as the cutting blades to withstand the friction caused by piercing hard materials.

Areas **Highlighted in Blue** require contact fit to the upper jaw and tang to prevent shattering.

Areas **Highlighted in Red** require an air gap, and blades may occasionally need to be ground down to provide clearance.

Tip blade contact with the clearance areas (**red**) can cause abnormal stress in the blade. This may cause the tip and/or guide blades to crack, break or shatter.

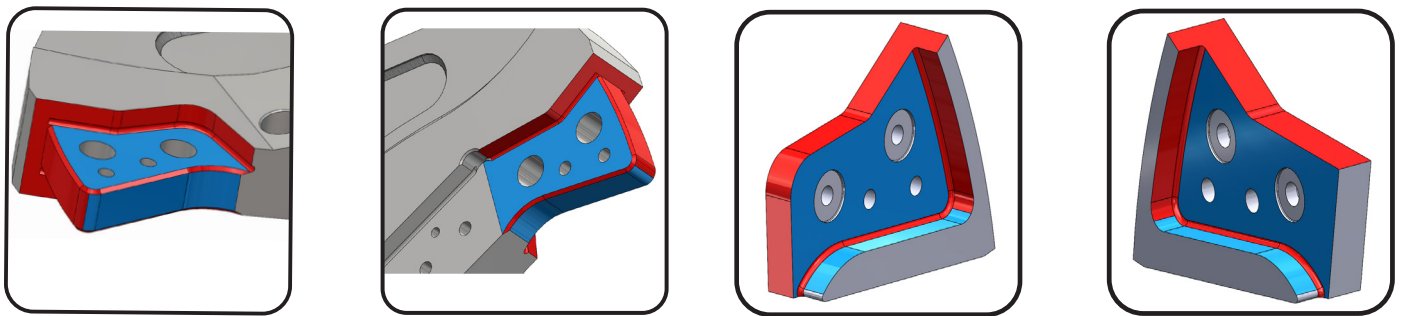

When necessary, build up the front lower edge of the tang (areas **highlighted in yellow**), following the procedures given in this manual. After welding, surfaces should be squared with a grinder and finished with a file and a machinist's straight edge.

It is critical that the tip blade pocket and tang surfaces are straight and true, without dings, deformations, high or low spots, or areas that are worn away.

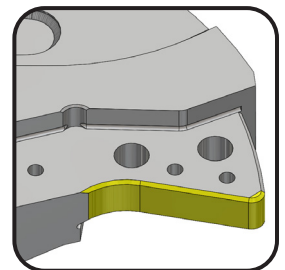

Tip blade bolts must not make hard contact with the bolt holes in the upper tang. In rare cases it has been noted that improper alignment of tip blade bolt holes and the bolt holes in the tang can cause the piercing blades to break through the bolt holes.

**When installing the tip blades, the bolts must be freely installed by hand, not with an air impact wrench.**

The bolts may start freely, but when the bolt shank, which is larger in diameter than the threads, enters the hole in the tang, the interference can cause side loading to the tip blades. This can cause the tips to break as they try to force the holes apart, or it may force the tips to seat improperly on the tang which can also cause tip failure. This is not a common issue, but one that should be noted as part of routine tip maintenance to prevent unnecessary costs and downtime. If this situation is encountered, contact the Genesis Service Department for further instructions.

## UPPER TIP BLADES

### Replacement

1. Remove blades using an air-impact wrench or breaker bar and multiplier.
2. Remove dust and debris from blade seats; wipe down with a rag and solvent.
3. Lightly file deformities from blade seat edges. Do not sand or grind face of blade seats.
4. Install new, clean blades. Lubricate the threaded holes in the blade and on the bottom of the bolt head where it will contact the blade.
5. Snug lubricated blade bolts by hand to hold them in place; push blades up and into the upper and rear surfaces of the seats.
6. Torque bolts to  $\frac{1}{3}$  of the final torque value.
7. Check for firm contact against blade seats.
8. With a feeler gauge, confirm there is a gap where the blades meet. Gap width by model is shown below the graphic to the right. A very narrow gap may be confirmed by shining a flashlight from below the blades and seeing light pass through. If the gap exceeds the specified limit, call the Genesis Service Department. If no gap exists, remove blades, lightly grind facing surfaces and repeat steps 5-8.
9. Torque bolts to  $\frac{2}{3}$  final value, and then to final value, using a cross bolt pattern.

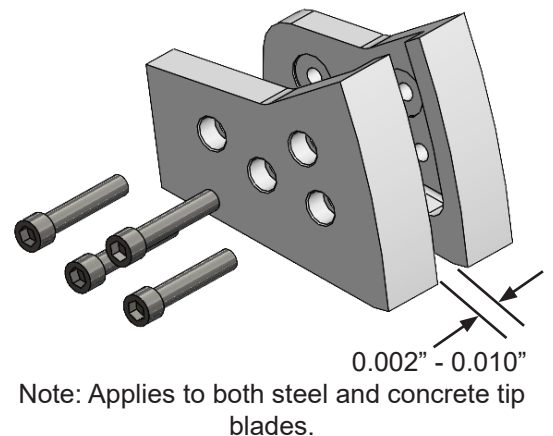

## NOTICE

Piercing blade bolts must be lubricated and torqued as specified in the Genesis Fastener Manual.

Correct clamping force is required to keep tips from moving on their seats. Over-tightening can cause bolt shanks to stretch, losing their clamping force. Loose bolts will cause the seating areas to erode.

## GUIDE BLADES

When necessary, shim the guide blade to maintain the gap within 0.010" to 0.020".

The top and bottom of the blade may be shimmed differently to maintain squareness. The difference should not be greater than 0.050" (1.3mm).

Rotate the guide blade when worn to a  $\frac{1}{8}$ " (3mm) radius. Replace the guide blade when more than 0.100" (2.5mm) of shims are required to keep the blade gap within tolerance.

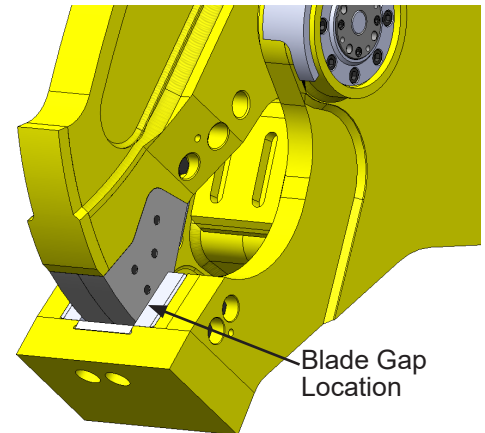

### **Shimming**

Slowly close the jaw so the tip blade begins to bypass the guide blade. Stop the jaw and check the gap between the guide blade and tip blade.

Cycle slowly, stopping at several points along the tip blade to check the gap each time.

Shim the guide blade as needed to keep the gap within the 0.020".

To install shims, loosen blade bolts and slide shims between the guide blade and guide blade seat.

Retorque bolts and recheck the gap.

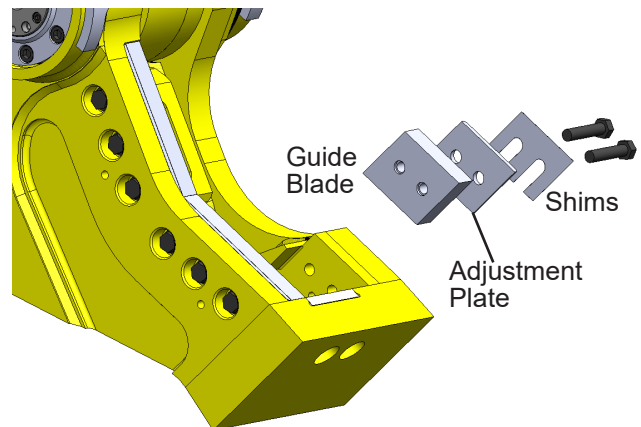

### **Rotation**

Remove the blade bolts, guide blade and shims. Rotate the blade end-for-end. Reinstall and torque bolts. Check gap; shim if required.

### **Replacement**

Remove guide blade and shims. Install new guide blade with no shims. Check blade gap and shim as needed. If more than 0.100" of shims are needed, upper tip blade must be rebuilt or replaced.

## GUIDE BLADES

### **Adjustment Plates**

Do not remove the guide blade adjustment plates from the lower jaw during routine blade rotation or replacement. These plates are custom-machined for each attachment and need only be replaced when lost, damaged or extremely worn.

Inspect the top of the adjustment plate for burrs, nicks or other imperfections that may prevent proper seating of the guide blade and cause errant blade gap readings. Clean the adjustment plate as necessary. Inspect the blade seat for damage or imperfections and clean or repair as necessary.

Replacement plates can be ordered from your Genesis dealer or the Genesis Parts Department with the serial number of your attachment. Because adjustment plates are serial number specific and custom machined, Genesis recommends ordering and keeping an extra set on-hand to reduce downtime.

Offset dowel or fastener holes are located in each adjustment plate. When replacing adjustment plates, make sure these holes are aligned with the corresponding holes in the blade seat. Chamfered adjustment plate edges go toward the back of the seat.

Do not grind blade seat areas.

## CUTTING BLADES

Proper maintenance of the cutting blades is required for optimal performance. Blade rotation extends blade life and improves cutting performance. Shimming to maintain blade tolerances helps prevent jamming. Dull blades make the excavator hydraulic system work harder and may cause structural damage to the attachment.

Inspect blades every eight hours of operation. Re-torque loose bolts and replace broken bolts. Grind away dents or mushrooming of blade edges at the end of each day to prevent upper jaw deflection, excessive blade wear and undue stress to upper and lower jaws.

Rotate blades to use all four cutting edges. Always use Genesis-approved blades. Blades that do not meet Genesis specifications can cause major problems, and using them may void the warranty.

Before performing any blade maintenance, read, fully understand and follow these safety rules.

- Wear personal safety equipment including gloves, safety glasses, safety boots and proper clothing.
- Safe blade maintenance requires two people - one to steady the blade while the other loosens the bolts.
- Blades are heavy and may fall out of blade seat if not adequately supported. Bystanders must stand clear.
- Never strike a blade with a hardened steel tool. The blade may fragment, creating sharp flying objects.

### **Removal**

Loosen the bolts, on one blade at a time, enough to loosen the blades.

If blades remain tight, insert a 7/16" drift pin into the through-hole on the lower jaw. Tap the drift pin with a hammer until the blade is loose.

Carefully remove bolts and blades.

Do not remove the adjustment plates from the lower jaw. These plates are custom-machined for your attachment and need only be replaced when damaged.

Inspect the top of each adjustment plate for burrs, nicks or other imperfections that may prevent proper seating of the blades and cause errant blade gap readings. Clean adjustment plates as necessary.

Do not grind on blade seat areas.

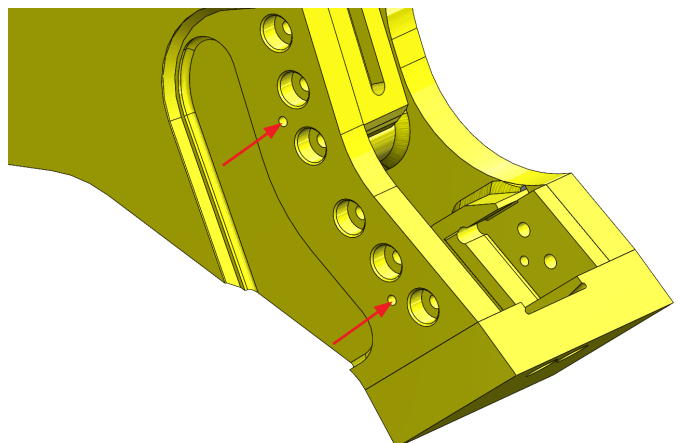

# CUTTING BLADES

## Rotation

Rotate blades when the cutting edges are worn to a 1/8" (3mm) radius.

Recommended rotation intervals are approximately 40-80 hours of operation, depending on the material being processed. Thin materials may require shorter rotation intervals. Blades must be replaced when all four edges are worn to 1/8" (3mm) radius.

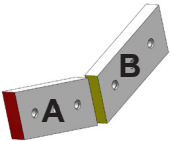
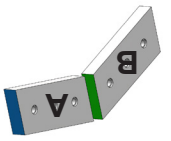
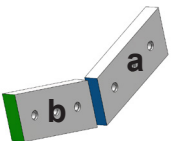
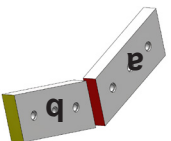
Original Blade Configuration	First Rotation Rotate both blades end-for-end	Second Rotation Rotate both blades front-to-back and exchange seat positions	Third Rotation Rotate both blades end-for-end
			

The following chart may be copied and used to track blade rotation.

40 - 80 Hours	Date	Hour Meter	Performed By
<b>Installed</b>			
<b>Rotation 1</b>			
<b>Rotation 2</b>			
<b>Rotation 3</b>			

# CUTTING BLADES

## Blade Gap

After each blade rotation, shim lower blades to eliminate any excess gap between upper and lower blades. Do not shim the upper blades. Use only Genesis shim kits.

The optimum gap is 0.005" to 0.010" and should not exceed 0.020".

## Blade Gap Measuring Procedure

Slowly close jaws until blades begin to bypass. Check blade gap with a feeler gauge.

Continue closing the jaws and checking the gap along the entire length of the blades.

Note: The gap will be consistent along the entire length of the blades if they have been rotated correctly.

If blade gap exceeds 0.015", shim lower blades. Replace blades when more than 0.060" of shims are required to maintain gap.

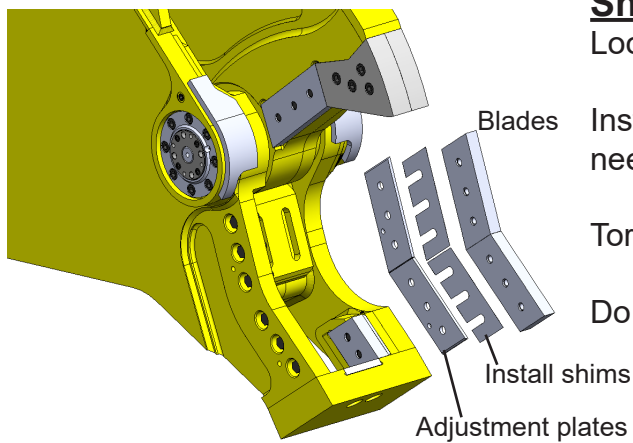
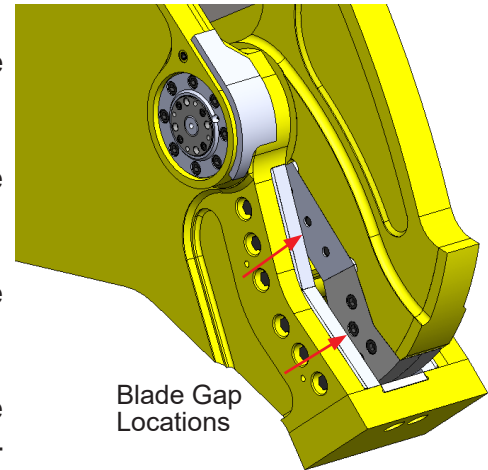

## Shimming

Loosen blade bolts.

Install shims between blades and adjustment plates as needed to bring into tolerance.

Torque bolts to spec and recheck tolerances.

Do not use more than 0.60" of shims.

## RAZOR BLADE

Check the razor blade for wear every eight hours of operation. Rotate when worn, using the edges in the sequence indicated by the illustration.

After rotation, check the gap between the razor blade and piercing blades. If the gap exceeds the maximum tolerance after new piercing blades have been installed, the razor blade must be replaced. Do not shim the razor blade.

Set-screws should be installed in unused bolt holes to prevent thread and hole damage. Replace set-screws when lost or damaged.

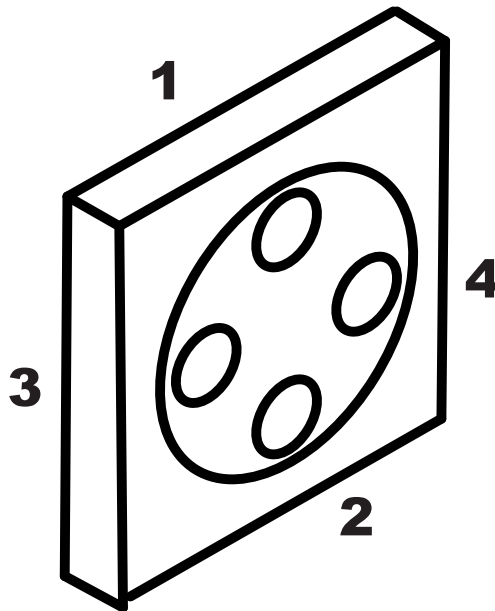

## GENERAL WELDING GUIDELINES

Build-up and hard-surfacing are welding procedures that protect the parent material of the jaws and keep the blades in good adjustment. Build-up is the welding procedure that restores the jaws to their original shape. Building up the jaws helps protect the blades and increases the life of the attachment. Hard-surfacing is the welding material added over the parent material (or build-up material) to create a wear-resistant surface.

Welding should not be performed until the jaws are work-hardened. Work-hardening can take up to 80 hours. However, jaws must not wear lower than the height of a new blade. If either jaw wears down lower than blade height, immediately stop operating the attachment and perform build-up and hard-surfacing as described in the following pages of this manual.

**When welding around blade seats or the piercing tip tang area, maintain the factory machined seat radius. If the rounded grooves are welded up, use a die grinder with a carbide tool to recut these areas to their original profile. Leaving a squared edge will eventually cause structural cracking. The radius provides a broader area to absorb structural stress.**

### Welding Ground Clamp

**Disconnect all battery ground cables or shut off master battery switch, if equipped. Failure to do so may cause excavator electrical problems, including permanent damage to onboard computer systems.**

**Connect ground clamp as close as possible to the area being welded without allowing current to pass through the pivot group, cylinder pin, cylinder, swivel, motor or slewing ring.**

**If you are welding on the lower jaw, connect weld clamp to the lower. If you are welding on the upper jaw, connect to the upper but not to the cylinder clevis. If needed, weld a piece of steel to the area for the grounding clamp and cut the piece off when welding is completed.**

### Welding Rules

Before you begin:

- Remove adjacent blades, as preheating and welding may cause blade damage.
- Wearing an approved respirator, grind the area to clean it, removing all existing hard-surfacing.
- Preheat area to 350° F (177° C). Maintain this temperature throughout the procedure. Do not exceed 450° F (232° C) interpass temperature.

During welding:

- Always grind and weld with the grain of the material.
- Peen each weld pass to relieve stress and harden the welds.
- Do not undercut the ends of the welds.
- Do not start or stop welds directly above a bolt hole or in the apex of the jaw.

After welding maintenance is complete:

- Cover the area with a heat blanket and allow it to cool slowly, approximately eight hours.
- Do not put the attachment into operation until the welds have been allowed to cool.

## BUILD-UP

Procedure:

Follow the General Welding Guidelines and Rules.

Determine the area to build up, using a straight-edge or square. Jaws must not wear lower than the height of a new blade. Use a new blade to help determine build-up height for the jaw.

Build up the jaw to slightly higher than the original parent material profile with E7018. Apply single passes in each line with the grain of the steel, peening after each pass.

After build-up is complete, grind material to be flush with a new blade.

Note: Closely monitor areas above guide blade bolt countersinks and below front two upper blade bolt countersinks. These are high-wear areas. If allowed to wear too far, parent material starts to fold into the countersinks, and it becomes time-consuming to clean out this area when access is needed for blade rotation and replacement.

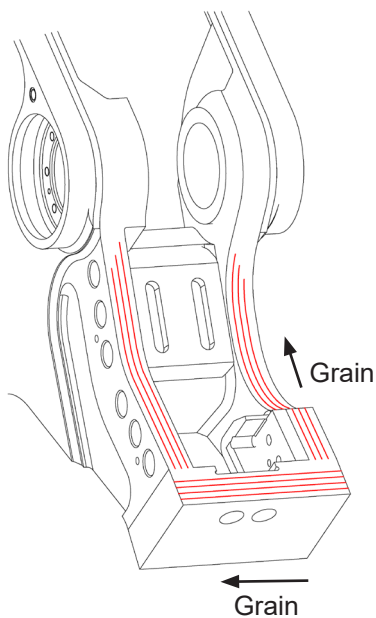
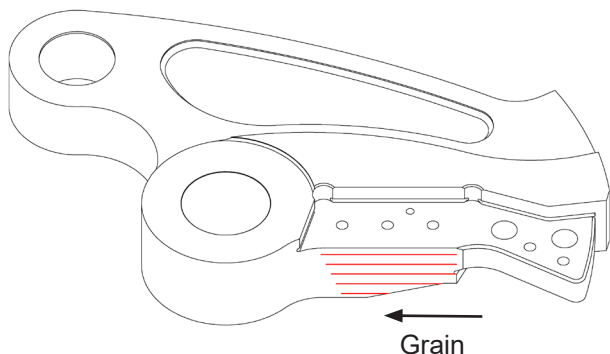

# HARD-SURFACING

Do not apply hard-surfacing directly to the parent material as this could cause toe cracking, and the hard-surfacing will break away.

Procedure:

Follow the General Welding Guidelines and Rules.

Apply a single pass stringer bead pattern, with the grain, using E7018 electrode. Peen each pass.

Do not apply a stringer directly on the edge. Start the first pass  $\frac{1}{4}$ " from the edge.

Stagger the ends of the stringer welds so they do not end in a straight line.

Cap each stringer bead with one pass of GenWire or GenRod to hard-surface. Do not apply more than two layers of hard-surfacing. Peen each pass.

Grind the ends of all stringer welds with the grain to taper  $1$ " to  $1\frac{1}{2}$ " (25 - 38 mm) to the parent material.

See the following page for hard-surfacing illustrations and instructions specific to each area of the jaws.

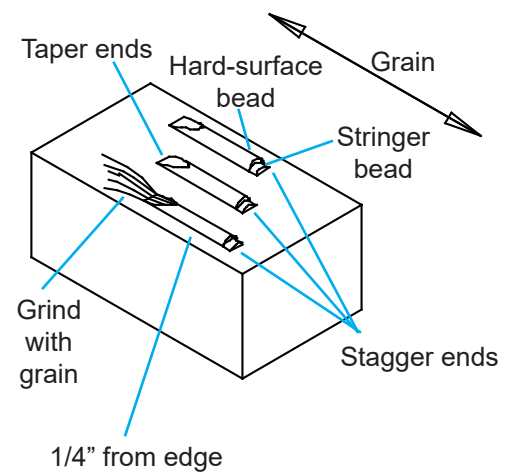

# HARD-SURFACING PATTERNS

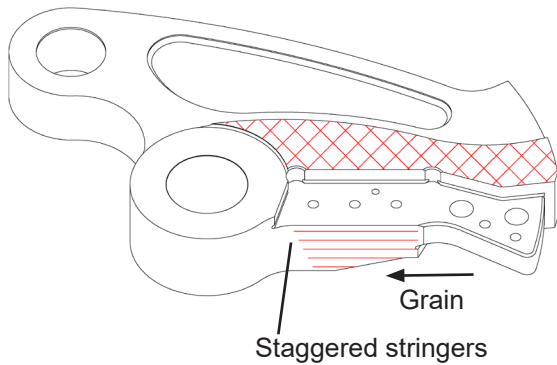

## Upper Jaw

Single passes approximately 1" apart. Begin just behind the piercing blade seats and continue toward the throat. Use three to five stringers, depending on the attachment model.

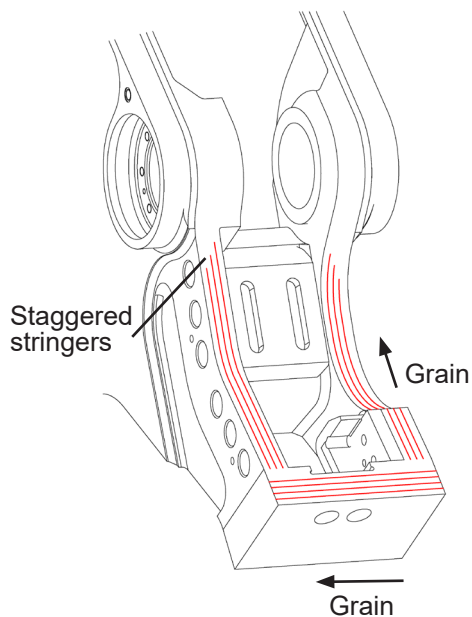

## Lower Jaw

Single passes approximately 1" apart. Work across the top of the chin plate and along the lower jaw toward the throat. Use two to three stringers, depending on the attachment model.

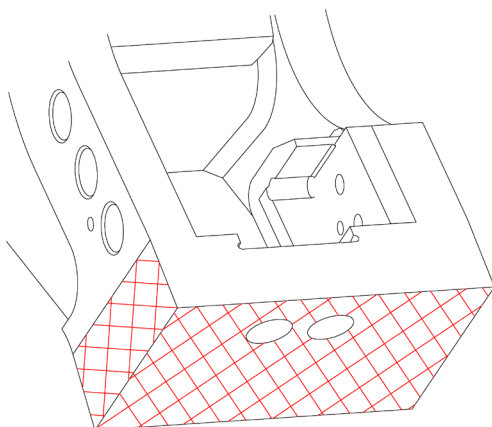

## Lower Jaw Chin

Crosshatch the chin plate with stringer beads at 45° angles to form 1" squares.

# HYDRAULIC/ROTATION MAINTENANCE

## Hydraulic Requirements

Operating the attachment below the recommended flow and/or pressure range will adversely affect performance and may damage the rotate motor.

Flow	Pressure
80 - 100 GPM	4500 - 5500 PSI
303 - 379 LPM	310 - 380 Bar

**Operating the attachment above the recommended flow and/or pressure range may damage the attachment and its hydraulic components.**

## Rotation Valve Input

For cooler and more efficient hydraulic system operation, set the input pressure and flow as indicated in the chart. The attachment rotation speed should be 3 - 4 RPM. Exceeding 4 RPM will result in rotation component damage.

Motor	Flow	Pressure
Radial Piston	1 - 3 GPM	2800 - 3000 PSI
	4 - 11 LPM	193 - 207 Bar
Gerotor	3 - 5 GPM	1800 - 2000 PSI
	11 - 19 LPM	124 - 138 Bar

The maximum case drain pressure measured at the shear while rotating and cycling the jaws must never exceed 40 PSI. Pressure increases during cold-weather operation.

## HYDRAULIC/ROTATION MAINTENANCE

### GenFlow Regeneration Valve

A regeneration valve features a GenFlow adjustment cartridge to control the timing of the shift between speed and power modes. When the cartridge is properly set, the processor closes rapidly until it begins to cut. The valve shifts, slowing jaw close and increasing power. You may hear a squeal or hiss as this happens. The valve shifts back into speed mode after the cut is complete.

The cartridge is factory-set, turned out approximately five turns. This setting is appropriate for most applications. However, the cartridge may be custom-set if necessary.

### Regeneration Valve Adjustment

Regeneration valve adjustment is a two-person job. The ground crew must be in full view of the operator at all times and must stand clear of the processor jaws when cycling.

Check the cycle time when the hydraulic fluid is warmed up, timing from full open to full closed and back to full open.

To shift into power mode sooner, turn adjustment cartridge out (counter-clockwise). To shift into power mode later, turn in (clockwise).

Loosen the lock nut with a 9/16" socket.

Turn cartridge 180° (half-turn, 145 PSI) with a 5/16" allen-head socket.

Tighten lock nut.

Check the cycle time.

Repeat until the preferred balance of speed and power is met. Final adjustment may require less than a half-turn.

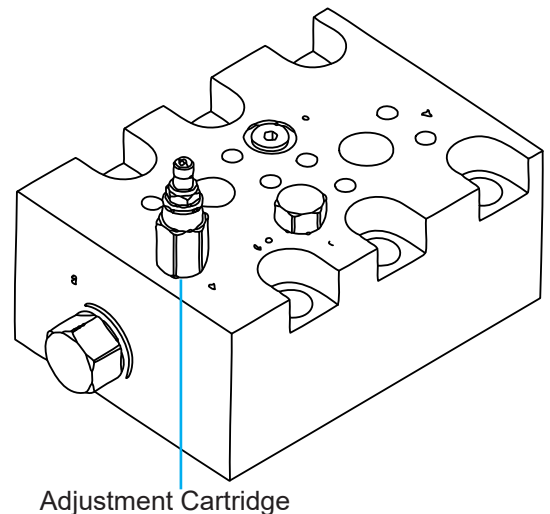

Adjustment Cartridge



Shut off the excavator and disable the hydraulics per OEM instructions before adjusting the cartridge.

# GENFLOW REGENERATION VALVE - HOW IT WORKS

**Jaw Close in Regeneration:** Oil that would normally leave the rod end of the cylinder and return to the tank is diverted to the bore end of the cylinder, increasing flow by approximately 50 percent and speeding up jaw close. In this mode, oil pressure on both rod and bore sides of the cylinder piston are basically equal and, although this speeds up the cylinder extend speed, it results in pressurized fluid on the rod side. If left in this mode, cylinder power is greatly reduced.

**Jaw Close in Power Mode:** To provide full power, when the upper jaw hits the material, the pressure rises. Once pressure exceeds the adjustment cartridge settings, it then shifts the rod oil back to the excavator hydraulic tank instead of the bore end of the cylinder. Pressure in the rod also drops, allowing full force from the bore pressure to be applied to the upper jaw for full cutting.

**Jaw Open:** Oil goes to the rod end of the cylinder, and bore oil goes back to the tank.

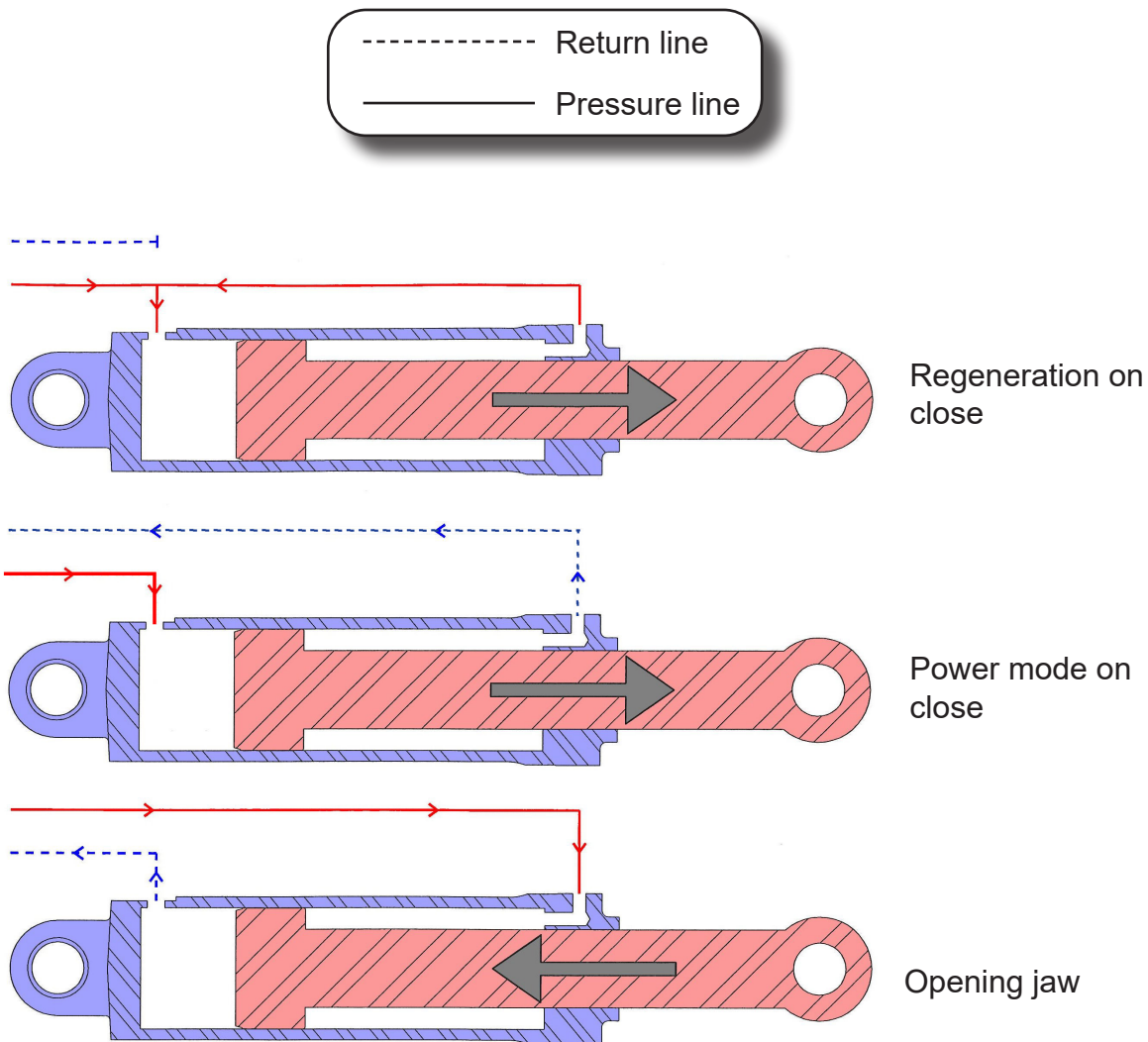

# GENFLOW REGENERATION VALVE

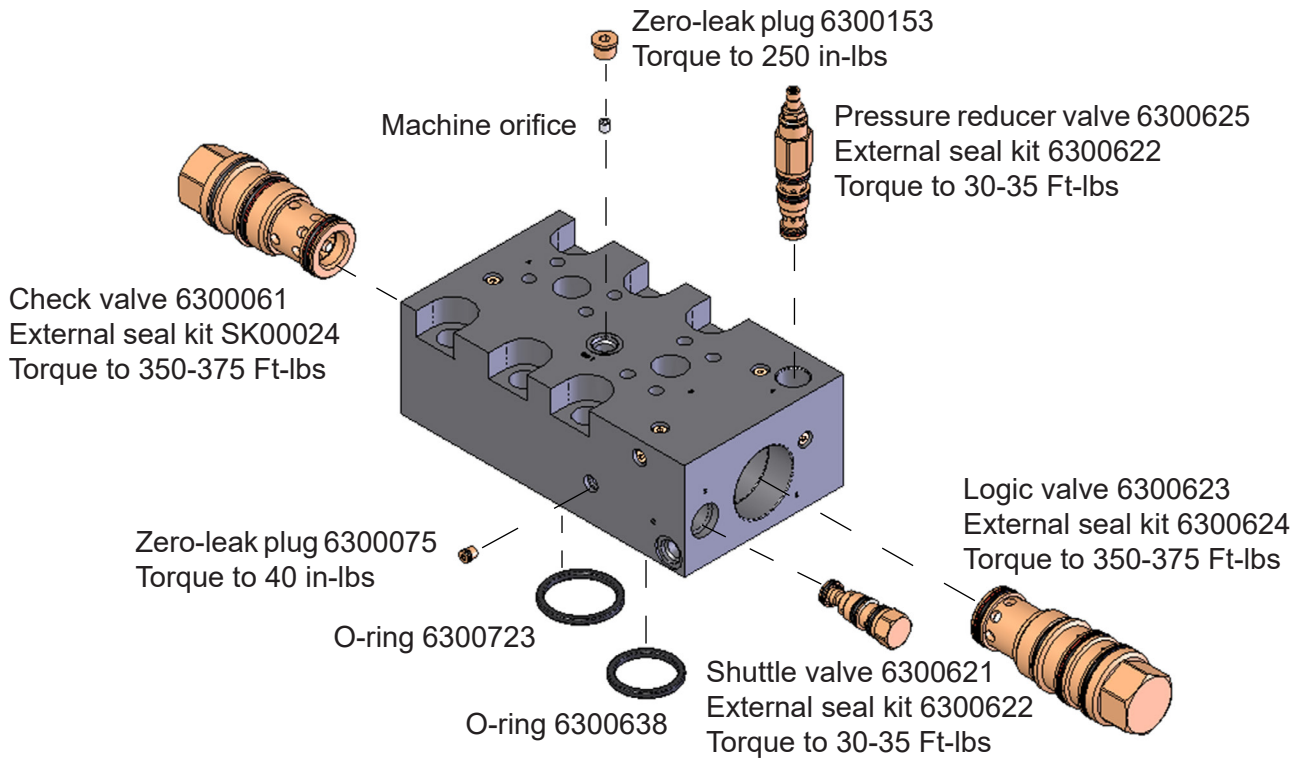

## SLEWING RING MAINTENANCE

Visually check slewing ring (rotation bearing) bolts every eight hours of operation. Do not reuse or re-torque these bolts. Loose or broken bolts, along with the bolts on either side, must be immediately replaced.

The bolts that secure the slewing ring are critical for safe attachment operation. Improper torque may cause the bolts to fail and the attachment to break free, which may result in serious personal injury and equipment damage. Improper torque will also cause uneven slewing ring wear.

Rotating components must be greased daily. Grease fittings are located on the outside of the slewing ring and on the inside of the rotating head assembly. Grease locations are marked with decals.

Grease each fitting and then rotate the attachment two full rotations.

For normal conditions above 32°F (0°C), use a lithium-based, premium grade 2 extreme-pressure grease. For temperatures below 32°F, use a grade 0 grease. **Do not use grease containing Molybdenum (Moly).**



Genesis GLG-2® anti-wear, extreme-pressure lithium grease, PN 6302601, is recommended for all temperature conditions.



Stand clear when the attachment is being rotated. Always stay in clear view of the operator.

# TROUBLE-SHOOTING GUIDE

Symptom	Possible Causes/Solutions
Low power	Check operating pressures and back pressure at port blocks on attachment
	Isolate attachment from excavator and check excavator pressures at boom tip
	Attachment may be partially stuck in regen mode; follow adjustment procedure in this manual
	If speed is good with low power, internal seals on logix cartridge may need to be replaced
	Possible cylinder, swivel or regen bypass (contact the Genesis Service Department for procedures)
Slow jaw open with low power	Pilot check valves in the regen valve may have worn or damaged seals
Slow jaw close	Check hydraulic flows from excavator
	Check regen valve adjustment if attachment is new
	Adjustment cartridge may have damaged seals or may be stuck open
	Regen check valve or logix valve may have damaged seals or may be stuck open
Good speed but attachment stalls before cutting	Regen adjustment cartridge is turned in too far, not shifting out of regen mode
Jaw drifts closed or can be pushed closed	Regen bleed down orifice may be plugged
	Regen pilot check valves may be leaking
	Directional valve on excavator may be leaking
Jaw closes suddenly and will not open	Ball valve may be closed on excavator
	Regen pilot check valves may be contaminated
	Excavator valve spool may be stuck
	If attachment has quick-coupled hydraulics, they may be partially disconnected or damaged
Hydraulics chatter while cutting	Tighten regen adjustment cartridge in quarter-turns and recheck speed
	Chattering may indicate a material jam
Jaw bounces back after hitting excavator relief on jaw open	Regen bleed down orifice is plugged
	Regen logix cartridge needs to be replaced/cylinder or swivel seal failure
Loud bang when shifting to speed mode	Broken spring or poppet in logix cartridge (regen valve)
Hydraulic system overheating	Check hydraulic system oil level for low or overfull condition
	Ensure clear path for hydraulic cooler-radiator and A/C condenser; clean coolers and radiator with compressed air and then pressure wash
	Check with excavator dealer on whether a hot weather package needs to be installed on the excavator. Note oil temperatures coming out of the attachment can run as high as 230 to 240 degrees Fahrenheit.

## TROUBLE-SHOOTING GUIDE

Symptom	Possible Causes/Solutions
Poor Cutting	Material is beyond attachment appetite range
	Material is harder than mild steel
	Blades are worn beyond 1/8" radius - rotate or replace
	Blade gaps are too wide for thin material
	Blade protection strips are too high, causing jaw deflection and excessive blade gaps
	Piercing tips are worn and need to be squared up or replaced
	Too much end play in pivot group - shim to 0.002" to 0.005"
	Wear in main bearings is causing jaw deflection and inconsistent blade gaps
	Pressures from excavator too low - check at attachment port blocks
	Attachment not kicking out of regeneration or kicking out at too high a pressure range - see Regeneration Valve section of manual
	Attachment swivel or cylinder is bypassing - contact the Genesis Service Department for procedures to check for bypass
Poor Piercing	Piercing tips are worn and need to be squared up or replaced
	Guide blades are worn - rotate or replace
	Excessive or insufficient gaps at piercing tip and guide blades - shim to specs given in Guide Blade section of manual
Material Jamming	Excessive blade gaps - shim to specs given in Cutting Blade section of manual
	Worn blades - rotate or replace
	Excessive or insufficient gaps at piercing tip and guide blades - shim to specs given in Guide Blade section of manual
	Thin material may be wrapping around blades - fold material or draw a larger amount of material into jaws
	Thin material in opening between the guide blades before the piercing tips entered the lower jaw - operators must be aware of this area at all times

# WARRANTY

## **Claim Procedure**

Notify the Genesis Service Department of the potential warranty claim prior to making the repair. Digital pictures are very helpful for diagnosing problems and recommending repairs.

Contact the Genesis Service Department before making alterations, changes or repairs to any component that is going to be considered for warranty. Not doing so will void all Genesis warranty consideration.

The Genesis Service Department will issue an authorization number to track the repair costs, outgoing parts, and/or defective parts returning to the factory.

Replacement parts must be ordered using a purchase order number. Shipping is standard ground. Overnight shipping is available by request, and Genesis will not cover the shipping charge.

When the repair is complete, submit an invoice to the Genesis Service Department within 30 days. Include itemized internal labor reporting, parts lists and invoices for outside contractors. Reference the authorization number on all invoices.

When returning parts for warranty consideration, include a copy of any related Genesis paperwork along with any other necessary documentation to ensure proper processing and credit. The Genesis Service Department will provide the necessary forms.

Your account will be credited when the warranty claim is accepted.

## **Blade Warranty**

Standard warranty on blades will only be considered on the first edge, and wear on the edge must be  $\frac{1}{8}$ " radius or less. Genesis does not warranty cutting blades that are cracked or broken from top to bottom (perpendicular to the long edge of the blade). Genesis also does not cover fasteners, the labor to replace wear components or collateral damage, such as blade seats, from broken blades, the piercing blade tang or adjustment plates.

**Please direct any questions to the Genesis Service Department: 715-395-5252**

# PARTS ORDER POLICY AND PROCEDURE

## **Parts Orders Should Include**

- Purchase order number
- Model and serial number of attachment
- Part number and quantity needed
- Shipping and billing address
- Method of shipment or required delivery date

## **Placing Orders**

Orders may be placed by phone or e-mail. To e-mail an order, use the form on the following page or your purchase order form. Contact information is located at the front of this manual.

## **Part Numbers**

Part numbers are listed in a separate Parts Manual or, if included, the Parts section of this manual. Contact the Genesis Parts Department with questions regarding part numbers, availability and pricing.

## **Shipping**

All orders will be shipped best way surface unless an alternate shipping method is requested. Shipping charges are not included in the purchase price of parts.

## **Invoices**

All invoices are due upon receipt. Any accounts with invoices open beyond 60 days are subject to review and may be placed on C.O.D. status without further notice.

## **Returns**

Many unused Genesis parts may be returned with proper documentation. Return shipping is the responsibility of the purchaser. Credit will be issued upon return, less a 25% restocking fee. Documentation is required for credit of returned parts. Contact the Genesis Service Department at 715-395-5252 for an RGA (Return Goods Authorization) number and form. An RGA must accompany every return. Items shipped without an RGA may be returned to sender.

## **Warranty Returns**

All parts returned to Genesis for warranty consideration must be returned with a completed RGA (Return Goods Authorization) provided by the Genesis Service Department. The form needs to be completed in its entirety, including any additional information requested by the Service Department. Return shipping is the responsibility of the sender and will be credited upon claim approval. A determination to accept or deny the claim will be made based upon the information available to Genesis. Warranty on purchased parts other than wear components is 6 months. Genesis does not cover labor costs to replace purchased parts replaced under warranty. There is no warranty period on wear parts or components.



## TOOL LIST

The following is a list of tools available for purchase from Genesis. This list may not include every tool used for this attachment, such as those that would also commonly be used for maintaining an excavator.

Part Number	Description
6900001	Service tool kit - includes part numbers 6900002 through 6900020
6900002	1½" 12-point socket, 1" drive
6900003	1-5/16" 12-point socket, 1" drive
6900004	⅝" impact hex bit socket, ¾" drive
6900005	¾" impact hex bit socket, ¾" drive
6900006	¾" drive female to 1" drive male adapter
6900007	1¼" combo wrench
6900008	Jet needle scaler
6900009	17mm socket, ¾" drive, metric impact
6900010	Torque multiplier, 2000 ft/lb
6900011	¾" drive torque wrench, 600 ft/lb
6900012	26" male/female ratchet, 1" drive
6900013	30" ratchet, 1" drive
6900014	5/16" LA hex key
6900015	1-5/16" combo wrench
6900016	⅞" combo wrench
6900017	1⅛" combo wrench
6900018	40mm 6-point impact socket, ¾" drive
6900019	46mm 6-point impact socket, ¾" drive
6900020	Tool box
6900021	⅞" impact hex bit socket, ¾" drive
6900022	1½" 6-point socket, 1" drive
6900023	⅞" impact hex bit socket, 1" drive
6900024	36mm 6-point impact socket, 1" drive

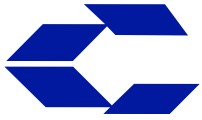

**GENESIS®**

The Promise of Performance.

## CONTACT INFORMATION

### Genesis Attachments

1000 Genesis Drive  
Superior, WI 54880 USA

Toll Free: 888-SHEAR-IT  
(888-743-2748)

Phone: 715.395.5252

E-mail:  
info@genesisattachments.com

### Europe/Africa/Middle East Genesis GmbH

Teramostrasse 23  
87700 Memmingen, Germany

Phone: +49 83 31 9 25 98 0

Fax: +49 83 31 9 25 98 80

genesis-europe.com

E-mail:  
info@genesis-europe.com

### Asia Pacific Representative Office

24 Upper Serangoon View #12-28  
Singapore 534205

Phone: +65 9673 9730

E-mail:  
tchoo@genesisattachments.com

### Central America & Colombia

Cra 13A #89-38 / Ofi 613  
Bogota, Colombia

Phone: +57 1 610 8160 / 795 8747

E-mail:  
contact@themsagroup.com

View and download all manuals: [genesisattachments.com/manuals](http://genesisattachments.com/manuals)

Patents: [genesisattachments.com/products/patents](http://genesisattachments.com/products/patents)