

GENESIS[®]

The Promise of Performance.

DemoPro 450 - 1200 (GDP)

SAFETY & OPERATOR'S MANUAL



CONTACT INFORMATION

Genesis Attachments

1000 Genesis Drive
Superior, WI 54880 USA

Toll Free: 888-SHEAR-IT
(888-743-2748)

Phone: 715.395.5252

E-mail:
info@genesisattachments.com

Europe/Africa/Middle East Genesis GmbH

Teramostrasse 23
87700 Memmingen, Germany

Phone: +49 83 31 9 25 98 0
Fax: +49 83 31 9 25 98 80
genesis-europe.com

E-mail:
info@genesis-europe.com

Asia Pacific Representative Office

24 Upper Serangoon View #12-28
Singapore 534205

Phone: +65 9673 9730

E-mail:
tchoo@genesisattachments.com

Central America & Colombia

Cra 13A #89-38 / Ofi 613
Bogota, Colombia

Phone: +57 1 610 8160 / 795 8747

E-mail:
contact@themsagroup.com

View and download all manuals: genesisattachments.com/manuals
Patents: genesisattachments.com/products/patents

PREFACE

To ensure years of safe, dependable service, only trained and authorized persons should operate and service your Genesis attachment. It is the responsibility of the product's owner to ensure the operator is trained in the safe operation of the product and has available this manual for review. It is the responsibility of the operator and maintenance personnel to read, fully understand and follow all operational and safety-related instructions in this manual. The attachment should not be operated until you have read and fully understand these instructions. Always use good safety practices to protect yourself and those around you.

Important

This operator's manual must accompany the attachment at all times and be readily available to the operator.

Manual Replacement

Should this manual become damaged or lost or if additional copies are required, immediately contact any authorized Genesis dealer or the Genesis Service Department at 888-743-2748 or 715-395-5252 for a replacement.

Registration Form

The Warranty Registration Form must be filled out by the dealer or customer and returned to Genesis indicating the date the attachment went into service.

Possible Variations

Genesis cannot anticipate every possible circumstance that might involve a potential hazard as the owner's requirements and equipment may vary. Therefore, the warnings in this publication and on the product may not be all-inclusive, and you must satisfy yourself that the procedure, application, work method or operating technique is safe for you and others before operating.

Public Notice

Genesis reserves the right to make changes and improvements to its products and technical literature at any time without public notice or obligation. Genesis also reserves the right to discontinue manufacturing any product at its discretion at any time.

Warranty

All work or repairs to be considered for warranty reimbursement must be pre-authorized by the Genesis Service Department. Any alterations, modifications or repairs performed before authorization by the Genesis Service Department will render all warranty reimbursement consideration null and void without exception. See page 50 for Warranty Claim Procedures.

Improper operation or improperly performed maintenance may render any warranty null and void.

TABLE OF CONTENTS

CONTACT INFORMATION	2
PREFACE	3
Important.....	3
Manual Replacement.....	3
Registration Form.....	3
Possible Variations.....	3
Public Notice.....	3
Warranty.....	3
SAFETY STATEMENTS	7
OPERATIONAL SAFETY	8
Read Manual Before Operating or Maintaining the Attachment.....	8
Personal Protection.....	8
Know Your Equipment.....	8
Before Operating.....	8
Check the Equipment.....	9
Stability.....	9
Know the Work Area.....	10
Starting Procedure.....	10
Place the Load Safely.....	10
Safely Operate Equipment.....	11
Transporting the Attachment.....	12
Equipment Condition.....	12
Working Overhead.....	12
Power Lines.....	12
Use Care with Hydraulic Fluid Pressure.....	13
Prioritized Oil Flow.....	14
Emergency Situations.....	14
Unsafe Conditions.....	14
Crystalline Silica Dust.....	14
Prop. 65 Warning for California Residents.....	14
Process Material Safely.....	15
Lift the Load Safely.....	15
Place the Load Safely.....	15
ATTACHMENT MARKINGS	16
ATTACHMENT INSTALLATION	17
ROTATOR INSTALLATION	18
Foot Switch Installation.....	18
Rotation Circuit.....	19
Rotation Circuit - Auxiliary Valve Rotation.....	21
Rotation Circuit - Gear Pump Rotation.....	22
Rotation Circuit - Accumulator Valve Rotation.....	23
HYDRAULIC START-UP	24
Start-up Procedure.....	24
GENERAL OPERATION INSTRUCTIONS	25
Start-up.....	25
Efficient and Productive Operation.....	25

TABLE OF CONTENTS

COMMON OPERATIONAL CONCERNS	26
Cutting Larger Materials	26
Chatter While Cutting	26
MAINTENANCE SAFETY	27
MAINTENANCE SCHEDULE	29
Scheduled Maintenance	29
Eight-Hour Checklist	30
LUBRICATION POINTS	31
BOLT TORQUE SPECS	32
JAW AND BLADE MAINTENANCE	33
Blade Bolts	33
GUIDE BLADES	34
Shimming	34
Rotation	34
Replacement	34
UPPER TIP BLADES	35
Blade Fuse	35
CUTTING BLADES	36
Removal	36
Rotation	37
Blade Gap	38
Blade Gap Measuring Procedure	38
Shimming	38
RAZOR BLADE	39
GENERAL WELDING GUIDELINES	40
Welding Ground Clamp	40
Welding Rules	40
HARD-SURFACING	41
Upper Tip Blades	41
Upper Tip Blade Rebuild Procedure	42
HARD-SURFACING PATTERNS	43
HYDRAULIC/ROTATION MAINTENANCE	44
Hydraulic Requirements	44
Rotation Valve Input	44
Rotation Valve Settings	44
GENFLOW REGENERATION VALVE	45
SLEWING RING MAINTENANCE	46
GEARBOX MAINTENANCE	47
Planetary Gearbox Lubrication	47
Gearbox Lube Change-out Procedure	47
TROUBLE-SHOOTING GUIDE	48
Attachment	48
Rotator	49
WARRANTY	50
Claim Procedure	50
Blade Warranty	50

TABLE OF CONTENTS

PARTS ORDER POLICY AND PROCEDURE	51
Parts Orders Should Include.....	51
Placing Orders.....	51
Part Numbers.....	51
Shipping.....	51
Invoices.....	51
Returns.....	51
Warranty Returns.....	51
PARTS ORDER FORM	52
TOOL LIST	53
CONTACT INFORMATION	54

NOTICE

For bolt torque specs, see the Genesis Fastener Manual.
genesisattachments.com/manuals

SAFETY STATEMENTS



This symbol by itself or used with a safety signal word throughout this manual is used to call attention to instructions involving your personal safety or the safety of others. Failure to follow these instructions can result in injury or death.



DANGER

This statement is used where serious injury or death will result if the instructions are not followed properly.



WARNING

This statement is used where serious injury or death could result if the instructions are not followed properly.



CAUTION

This statement is used where minor or moderate injury could result if the instructions are not followed properly.

NOTICE

This statement is used where property damage could result if the instructions are not followed properly.

OPERATIONAL SAFETY

Read Manual Before Operating or Maintaining the Attachment



Read this manual before attempting to operate the attachment. This operator's manual should be regarded as part of the attachment. For proper installation, operation and maintenance of the attachment, operators and maintenance personnel must read this manual.



WARNING

Serious injury or death could result if appropriate protective clothing and safety devices are not used.

Personal Protection

Use protective clothing and safety devices appropriate for the working conditions. These may include but are not limited to:

- ✓ Hard hat
- ✓ Safety glasses, goggles or face shield
- ✓ Hearing protection
- ✓ Safety shoes
- ✓ Heavy gloves
- ✓ Reflective clothing
- ✓ Respirator or filter mask



Safety matters

Know Your Equipment



Know your attachment's capabilities, dimensions and functions before operating. Inspect your attachment before operating and never operate an attachment that is not in proper working order. Remove and replace any damaged or worn parts.

Before Operating

- ✓ Warn all others in the area that you are about to start operation.
- ✓ Perform the Check the Equipment steps outlined in this manual.
- ✓ Check underneath and around the machine. Make sure all personnel and equipment are clear from the area of operation and equipment movement. Check clearances in all directions, including overhead.
- ✓ Be properly seated in the operator's seat.
- ✓ Do not attempt to operate until you have read and fully understand this manual and the OEM manual for the carrier.

OPERATIONAL SAFETY

Check the Equipment

Before use, check the equipment to ensure it is in good operating condition.

Check the following:

- ✓ Grease fittings. Pump grease at all fitting locations, see page 31.
- ✓ Hydraulic fluid level. Add hydraulic fluid as required.
- ✓ Hydraulic hoses and hose connections for wear or leaks. Repair or replace any damaged hoses or connections.
- ✓ All control levers for proper operation.
- ✓ Rotation bearing. Visually check for loose or damaged bolts. If repair is required, refer to qualified personnel.
- ✓ Grease rotation bearing and pinion gear.
- ✓ Check for loose or missing pin retaining bolts.
- ✓ Check cylinders for dents (barrel) or dings (rod).



**GOOD
CONDITION**



WARNING

Serious injury or death could result if warnings or instructions regarding carrier stability and the work area are not followed properly.

Stability

Your Genesis attachment is sized for carrier stability. However, improper operation, faulty maintenance or unauthorized modifications may cause instability.

- ✓ Know the working ranges and capacities of the carrier to avoid tipping.
- ✓ Use the recommended carrier counter weight.

The following conditions affect stability:

- Ground conditions
- Grade
- Weight of attachment
- Contents of attachment
- Operator judgement



For greater stability, knuckle the attachment to bring the load closer to the center of rotation (center of gravity) while lifting. Use extra caution during reaching to avoid tipping.

OPERATIONAL SAFETY

Know the Work Area

Check clearances in the work area. Keep all bystanders at a safe distance. Do not work under obstacles. Always check your location for overhead and buried power lines or other utilities before operation.

Check ground conditions. Avoid unstable or slippery areas. Position the carrier on firm level ground. If level ground is not possible, position the carrier to use the attachment to the front or back of the carrier. Avoid working over the side of the carrier.

To reduce the risk of tipping and slipping, never park on a grade exceeding 10% (one-foot rise over the span of a ten-foot run).

Starting Procedure

Before operating, walk completely around the equipment to make certain no one is under it, on it or close to it. Keep all bystanders at least 75 feet away from the area of operation and equipment movement. Let all other workers and bystanders know you are preparing to start. DO NOT operate until everyone is clear.

Always be properly seated in the operator's seat before operating any carrier controls.

To start:

- ✓ Make sure all controls are in the center (neutral) position.
- ✓ Be properly seated.
- ✓ Slowly operate all functions to check for proper operation and to bleed air from the hydraulic system.

To shut down:

- ✓ Return your Genesis attachment to a rest position on the ground.
- ✓ Shut off the carrier engine.
- ✓ Work controls in all directions to relieve hydraulic pressure, per excavator manufacturer's instructions.



WARNING

Serious injury or death could result if warnings or instructions regarding safe operation are not followed properly.

Place the Load Safely

Do not move the attachment, or anything held in the jaws, over people, equipment or buildings. Do not throw or drop the contents. Operate the controls smoothly and gradually.

OPERATIONAL SAFETY

Safely Operate Equipment

Do not operate equipment until you are trained by a qualified operator in its use and capabilities.

See your carrier's manual for these instructions.

- ✓ Operate only from the operator's seat. Check the seat belt daily and replace if frayed or damaged.
- ✓ Do not operate this or any other equipment under the influence of drugs or alcohol. If you are taking prescription medication or over-the-counter drugs ask your medical provider whether you can safely operate equipment.
- ✓ Never leave equipment unattended with the engine running or with the attachment in a raised position. Apply the brakes before exiting the equipment.
- ✓ Do not exceed the lifting capacity of your carrier.
- ✓ Avoid conditions that can lead to tipping. The carrier can tip when operated on hills, ridges, banks and slopes. Avoid operating across a slope which could cause the carrier to overturn.
- ✓ Reduce speed when driving over rough terrain, on a slope, or when turning to avoid overturning the carrier.
- ✓ Never use the attachment as a work platform or personnel carrier.
- ✓ Keep all step plates, grab bars, pedals and controls free of dirt, grease, debris and oil.
- ✓ Never allow anyone to be around the equipment when it is operating.
- ✓ Do not operate poorly maintained or otherwise faulty equipment. Inform the proper authority and DO NOT resume operation until the problem has been fixed.
- ✓ Do not alter or remove any safety features.
- ✓ Know your work site safety rules as well as traffic rules and flow. When in doubt on any safety issue, contact your supervisor or safety coordinator for an explanation.
- ✓ A heavy load can cause equipment instability. Use extreme care during travel. Slow down on turns and watch out for bumps. The equipment may need additional counter-weights to counterbalance the weight of the attachment.



OPERATIONAL SAFETY

Transporting the Attachment

- ✓ Travel only with the attachment in a safe transport position to prevent uncontrolled movement. Drive slowly over rough ground and on slopes.
- ✓ When driving on public roads use safety lights, reflectors, Slow Moving Vehicle signs, etc., to prevent accidents. Check local government regulations that may affect you.
- ✓ Do not drive close to ditches, excavations, etc., as cave-in could result.
- ✓ Do not smoke when refueling the prime mover. Allow room in the fuel tank for expansion. Wipe up any spilled fuel. Secure cap tightly when done.

Equipment Condition

Never operate poorly maintained equipment. When maintenance is required, repair or replace parts immediately.



WARNING

Serious injury or death could result if warnings or instructions regarding working overhead are not followed properly.

Working Overhead

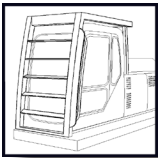

Avoid handling material overhead whenever possible. Safety glass and wire mesh cab guarding must be installed to protect the operator from flying debris that may be created during handling. Falling Object Protection Structures, or FOPS, are necessary for any application where material is to be handled overhead.



DANGER

Serious injury or death will result if warnings or instructions regarding power lines are not followed properly.

Power Lines

Do not operate the machine near energized power lines. All local, state/provincial and federal regulations must be met before approaching power lines, overhead or underground cables, or power sources of any kind with any part of the carrier or attachment. Always contact the appropriate utility when operating near power lines. The lines should be moved, insulated, disconnected or de-energized and grounded before operating in the area.



Current in high voltage lines may arc some distance from the wire to a nearby ground. Keep all parts of the machine at least 50 feet (16m) away from power lines.

OPERATIONAL SAFETY



WARNING

Serious injury or death could result if warnings or instructions regarding hydraulic fluid pressure are not followed properly.

Use Care with Hydraulic Fluid Pressure

Hydraulic fluid under pressure can penetrate the skin and cause serious injury or death. Hydraulic leaks under pressure may not be visible.

- ✓ Keep unprotected body parts, such as face, eyes and arms as far away as possible from a suspected leak. Flesh injected with hydraulic fluid may develop gangrene or other permanent injuries.
- ✓ If injured by injected fluid see a doctor immediately.
- ✓ Wear safety glasses and protective clothing and use a piece of cardboard or wood when searching for hydraulic leaks.

Do Not Use Your Hands!
See illustration below.

- ✓ Hydraulic oil becomes hot during operation. Do not let hydraulic oil or components contact skin, as it could cause severe burns. Allow hydraulic components to cool before working on them. Use appropriate protective clothing and safety equipment. If burned, seek immediate medical attention.

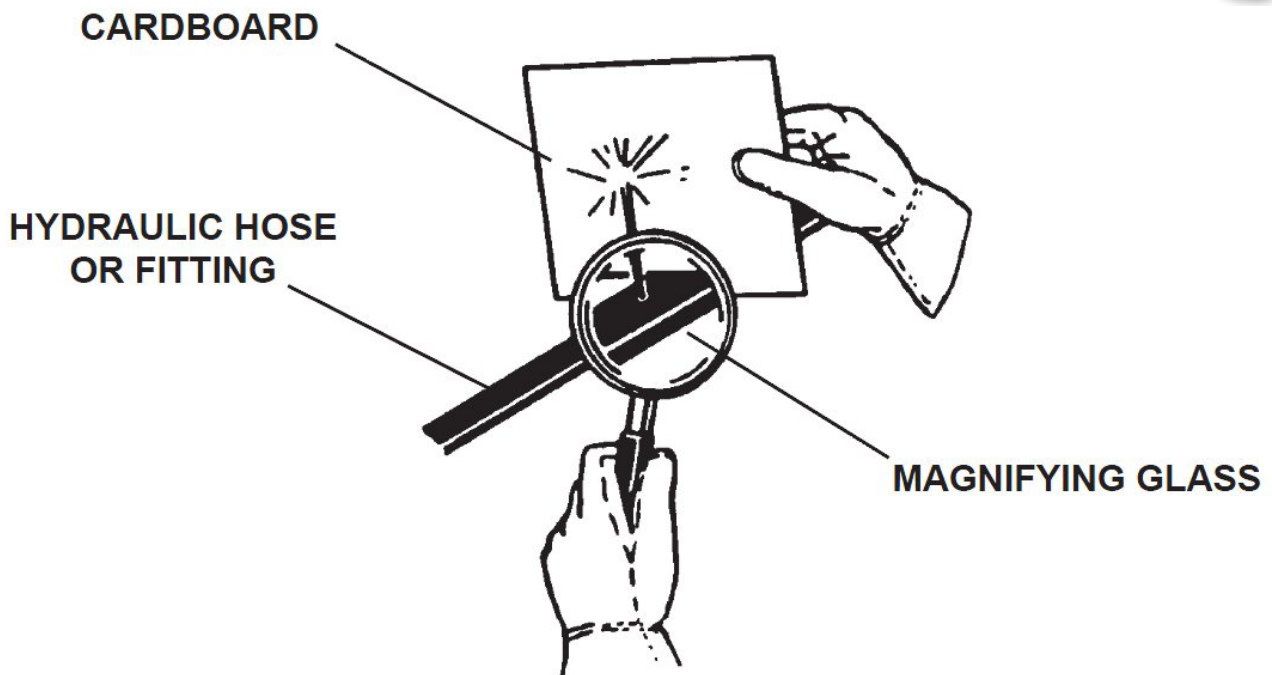
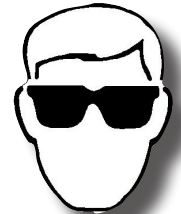

OPERATIONAL SAFETY

Prioritized Oil Flow

Equipment operators must ensure there is prioritized oil flow to the main valves in overhead operations or high reach conditions.

Emergency Situations

Always be prepared for emergencies. Make sure a fire extinguisher is available. Be familiar with its operation. Make sure to inspect and service the fire extinguisher regularly. Make sure a first aid kit is readily available.



Unsafe Conditions

Do not operate if an unsafe condition exists. Stop operation immediately, shut down the machine and report the unsafe condition to the proper authority. Equipment operation and maintenance practices directly affect your safety and the safety of those around you. Always use common sense while operating and be alert to unsafe conditions.

Crystalline Silica Dust

It is recommended to use dust suppression, dust collection and if necessary, personal protective equipment during the operation of any attachment that may cause high levels of dust.

 **DANGER** Exposure to respirable crystalline silica dust along with other hazardous dusts may cause serious or fatal respiratory disease.

IMPORTANT: Concrete and masonry products contain silica sand. Quartz, which is a form of silica and the most common mineral in the Earth's crust, is associated with many types of rock.

Some activities that may have silica dust present in the air include demolition, sweeping, loading, sawing, hammering, drilling or planing of rock, concrete or masonry.

It is recommended to use dust suppression (such as water) or dust collection (such as a vacuum) along with personal protective equipment if necessary during the operation of any attachment that may cause high levels of silica dust.



Prop. 65 Warning for California Residents

 **WARNING** This product may contain chemicals known to the State of California to cause cancer, birth defects, or other reproductive harm. For more information visit: P65Warnings.ca.gov

OPERATIONAL SAFETY



WARNING

Using your Genesis attachment in unauthorized applications may create an unsafe situation and will void the warranty.

Process Material Safely

- Do not process hardened steel material such as tool steel, railroad rail, axles, springs, machined parts or high-strength material. Hardened/high-strength material breaks, rather than shears, which may cause flying debris. It will also cause damaging decompression spikes to your Genesis attachment and base carrier hydraulic systems.
- Do not operate any functions of the carrier while cutting or crushing with your attachment, including boom and drive functions.
- Do not pull down structures with your Genesis attachment. Doing so may cause falling debris or material to break free and exceed the capacities of the carrier, causing a tipping hazard and rotation component failures.
- Do not use rotation to pry or break material. Doing so exerts high back-driving forces and spikes to the rotation circuit components that cannot be cushioned hydraulically. It may also cause motor and gearbox failures. The rotator should only be used for positioning an attachment.
- Do not process pressurized containers unless the main valve has been removed and you are absolutely certain the container is empty.
- Do not process spring loaded brake chambers and automotive struts as the release of compressed springs is extremely dangerous. Nothing made of spring material or containing springs should be processed.

Lift the Load Safely

- The hydraulic system has been preset and tested by your dealer. Do not alter hydraulic settings without consulting an authorized Genesis dealer or the Genesis Service Department. Doing so will void the warranty and may cause structural damage, accidents or tipping.
- Make sure the load is held securely in the jaws. Do not move a loaded attachment if load is loose or dangling. Make sure the load is pinched between the jaws – never cradle a load.
- For greater stability, knuckle the attachment to bring the load closer to the center of rotation (center of gravity) while lifting. Use extra caution during reaching to avoid tipping.

Place the Load Safely

- Do not move the attachment, or anything held in the jaws, over people, equipment or buildings. Place the load gently. Do not throw or drop the contents.
- Operate the controls smoothly and gradually. Jerky controls are hazardous and may cause damage to the carrier.
- Avoid fire hazards. Keep the area clean. Remove all flammable materials from the area during any welding or heating process. Have a fire extinguisher nearby and know how to use it.
- Never substitute pins or bolts. Use factory supplied pins. Replace all bolts with the same size and grade. Failure to do so may cause serious injury or death.
- Use your Genesis attachment only as directed in this manual. Do not use the attachment to lift and move other objects. Doing so may cause instability and tipping.

ATTACHMENT MARKINGS

Decals are necessary for safe operation and maintenance. To reorder, contact your Genesis dealer or call 715-395-5252.

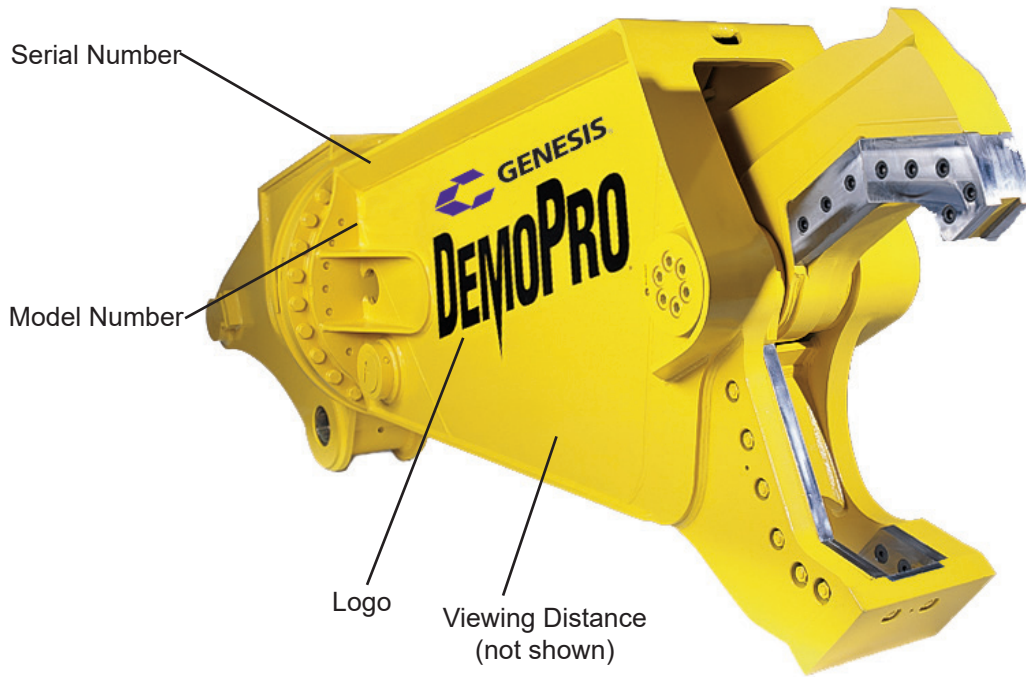

ATTACHMENT INSTALLATION

The attachment is usually shipped in an upright position. Extreme care must be used when inverting the attachment for installation.

Follow the excavator OEM's removal and safety instructions to remove the bucket or other stick attachments.

Position the attachment upside down on flat, solid ground. Blocking may be required to raise the mounting bracket into proper position.

Track the excavator to the attachment with the jaws facing the operator. Lift the excavator stick over the attachment, carefully positioning the stick tip connection with the attachment's mounting main pivot bore. Pin the excavator stick to the attachment.

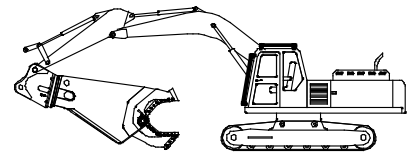
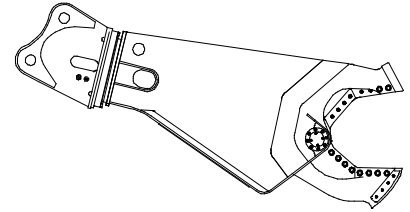

WARNING

Removing any connecting pin may be hazardous. To remove a connecting pin, position the attachment on the ground and properly support.



WARNING

Particles may fly when a pin is struck. Use a drift pin or mallet when striking pins. Keep all personnel at a safe distance.

Slowly raise the boom to lift the attachment, allowing the attachment cylinder pivot connection to come within range of the excavator cylinder stroke.

Extend the excavator cylinder until the rod-eye/linkage bore lines up with the attachment cylinder pivot connection. Pin excavator cylinder to the attachment.

Install excavator hydraulic hoses, supply and return, from the stick tip to the attachment manifold blocks.

Note: Genesis' standard pin material is Induction Hardened Chrome (IHC), which is to be used for all direct pin 2nd and 3rd member mounting. To avoid risk of pin failure when using a pin grabbing coupler, the standard IHC pins must be replaced with a heat-treated pin material from Genesis.

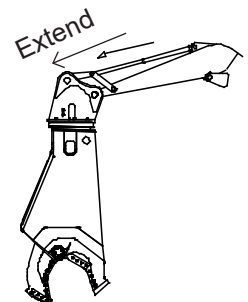
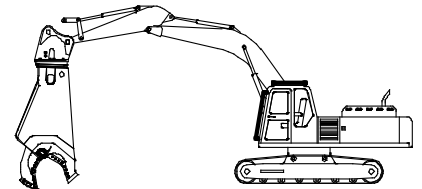

WARNING

Be sure hydraulic pressure is relieved before disconnecting hydraulic fittings. Remove necessary fittings SLOWLY.

ROTATOR INSTALLATION

The rotator requires a 1/2" case-drain line with a minimum working pressure rating of 250 PSI from the rotation head of the attachment to the filter on the excavator hydraulic reservoir. The maximum case-drain pressure measured at the attachment while rotating and cycling the jaws must never exceed 40 PSI.

Use the correct fittings. Secure the case-drain line to the excavator stick.

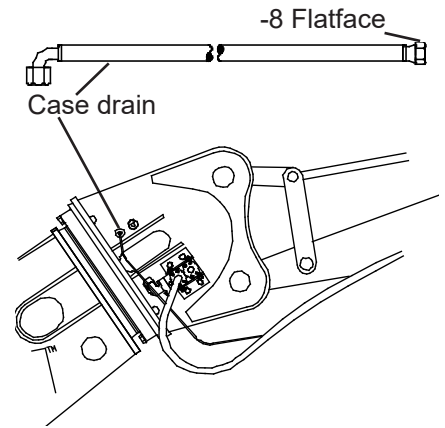

Foot Switch Installation

Install the foot switch in the excavator and connect with electrical harness. Consult excavator dealer when using an alternate to the Genesis supplied foot switch.

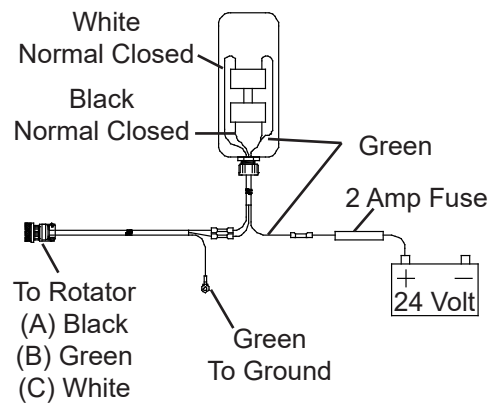

ROTATOR INSTALLATION

Rotation Circuit

The rotator requires an additional hydraulic circuit. One of the three available options has been supplied with the attachment. The diagrams below show the installation of the additional circuit.

Electric Valve

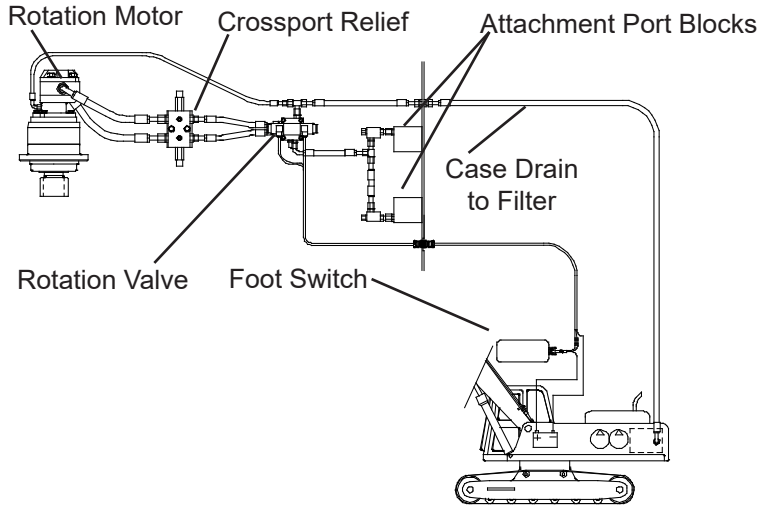

Auxiliary Valve

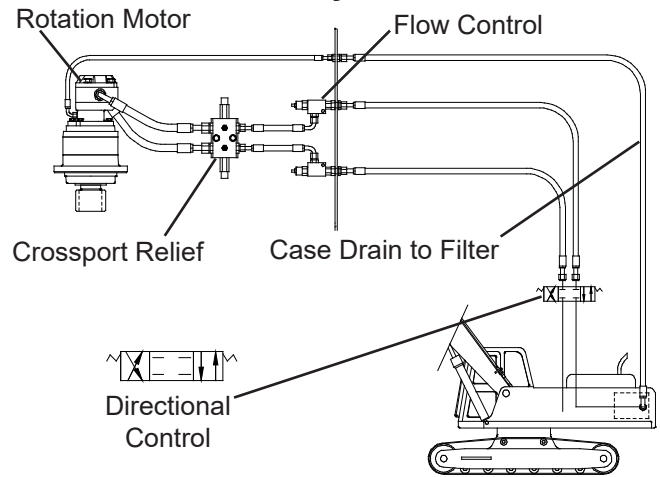

Gear Pump

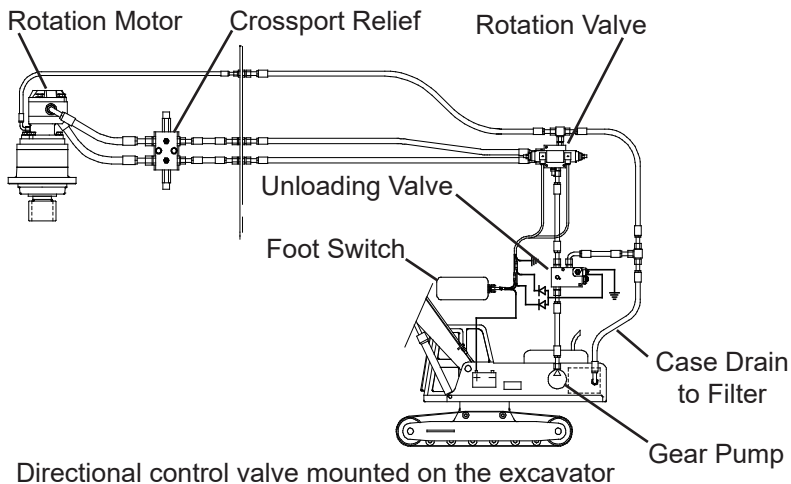

ROTATOR INSTALLATION

To meet diverse customer needs, Genesis offers several rotation valve options. These options vary in mounting, function, factory-supplied and customer-supplied parts, and operating advantages. For information on each type of rotation circuit, see the chart below and information on the following pages.

Valves are factory-set and should not need adjustment. If you believe adjustment is necessary, contact the Genesis Service Department. Unauthorized valve adjustment may void the warranty.

All rotation circuits use the same procedure for setting flow:

- Rotate attachment, timing one complete revolution.
- Adjust the corresponding flow control until the revolution time is 14-16 seconds.
- Repeat in opposite direction.

Note: Genesis does not recommend using the excavator bucket circuit for rotation circuit directional control as it may damage the rotation components.

Rotation	Auxiliary Valve	Gear Pump	Accumulator Valve
Mounting	On attachment	Crossover relief on attachment; valve on excavator	On attachment
Function	Supplies crossover relief for rotation motor; regulates pressure and flow	Supplies crossover relief for rotation motor; unloads gear pump; provides directional control.	Oil from jaw open/close circuit charges accumulator; attachment rotates when accumulator is electrically actuated
Factory Supplied	Valve	Valves; footswitch and wire harness	Accumulator; valve; footswitch and wire harness
Customer Supplied	Rotation circuit with directional control from excavator; case drain	Gear pump; case drain; must install wiring	Case drain; must install wiring
Advantage	Allows attachment to open/close and rotate simultaneously	Allows attachment to open/close and rotate simultaneously	Lower installation cost; easier move to other excavators

ROTATOR INSTALLATION

Rotation Circuit - Auxiliary Valve Rotation

Setting the crossover reliefs:

1. Increase supply pressure to the rotation valve to 2500 PSI.
2. Install pressure gauges on relief test ports.
3. Plug hoses at motor or secure the attachment from rotating.
4. Pressurize the valve to rotate.
5. Adjust the corresponding relief valve to the pressure specified in the rotation valve setting table.
6. Repeat for the other direction.
7. Reduce supply pressure to the pressure-reducer valve setting specified in the rotation valve setting table.

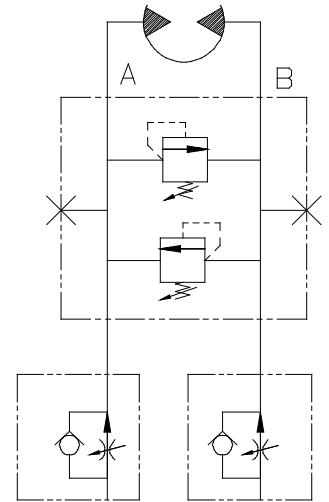
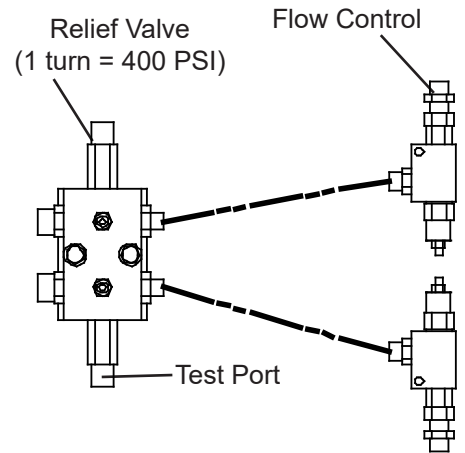

ROTATOR INSTALLATION

Rotation Circuit - Gear Pump Rotation

Setting the crossover reliefs:

1. Install a pressure gauge on the unloading valve, unplug the wires to the directional valve, and energize the valve on the unloading valve.
2. Adjust the unloading valve to 2500 PSI.
3. Reconnect the wires to the directional valve.
4. Plug hoses at motor or secure the attachment from rotating.
5. Press the switch to rotate left or right.
6. Adjust the corresponding relief valve to the pressure specified in the table.
7. Repeat for the other direction.
8. Set the unloading valve before operating.

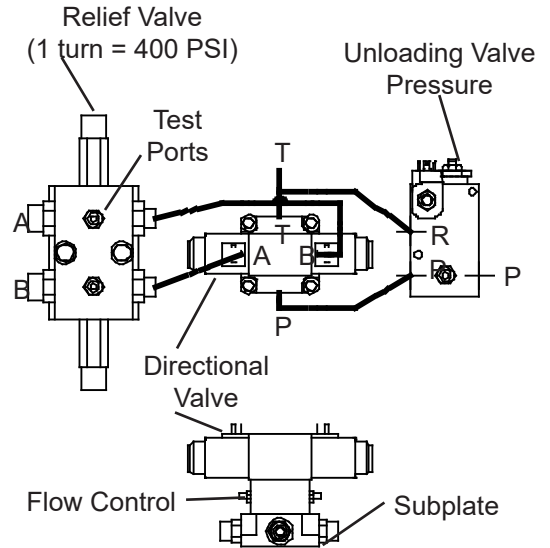

Setting the unloading valve:

1. Install a pressure gauge on the unloading valve, unplug the wires to the directional valve and press the switch to rotate left or right.
2. Adjust the unloading valve to the pressure specified in the table.
3. Plug the wires back into the directional valve.

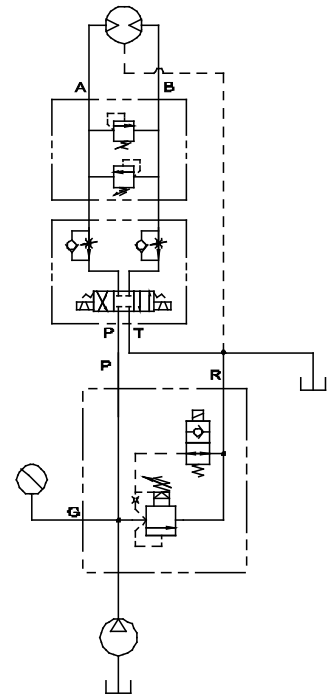

ROTATOR INSTALLATION

Rotation Circuit - Accumulator Valve Rotation

Setting the crossover reliefs:

1. Install pressure gauges on the G1 and G2 ports of the control valve assembly.
2. Disconnect hoses from motor; plug ports A and B on the control valve.
3. Close jaws and hold full pressure to close.
4. Energize the circuit to rotate the attachment.
5. Measure pressure at G1 and G2 ports; subtract low number from high number.
6. Release pressure and adjust the corresponding relief valve, if needed, to achieve correct relief pressure.
7. Repeat steps 3-6 to reach correct setting.
8. Repeat procedure in the other direction for the other relief valve.
9. Reconnect hoses.

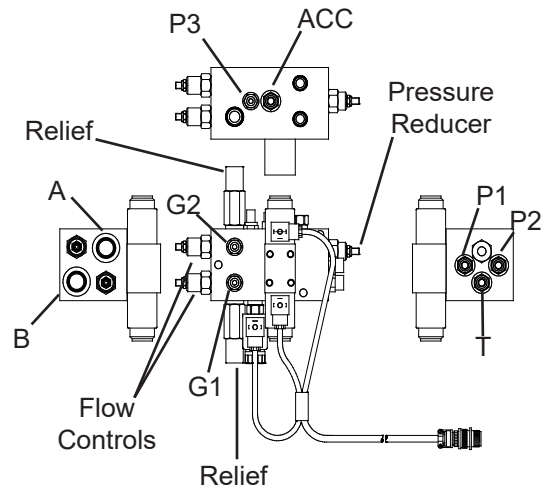

Setting the pressure reducer:

1. Install a pressure gauge on the P3 port of the control valve assembly.
2. Close jaws and hold full pressure to close.
3. Measure the pressure at the P3 gauge.
4. Release pressure; if measured pressure is not 3000 PSI, adjust reducer and repeat procedure until 3000 PSI is achieved.

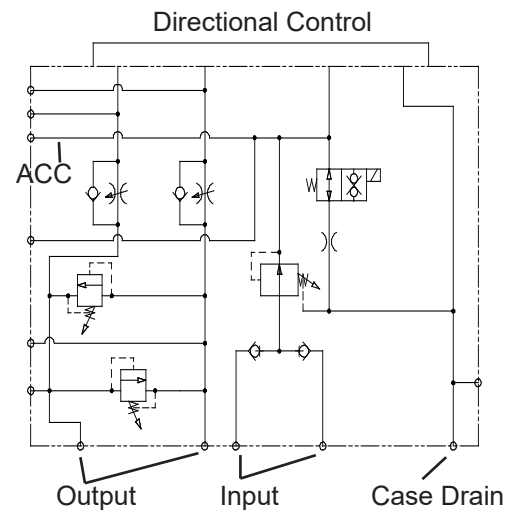

HYDRAULIC START-UP

Genesis attachments are designed to operate under full excavator pressure or up to 5500 PSI. Due to these high pressures, it is important that air is bled from the attachment cylinder after installation. Failure to follow these procedures could result in cylinder seal damage and/or excavator hydraulic system damage.

Start-up Procedure

- ✓ Check the excavator hydraulic tank for proper fluid level.
- ✓ Excavator oil should be warmed up before hooking up attachment lines in cold weather. If oil is cold, air from the cylinder will be pushed into the oil tank, causing oil to foam. This problem takes hours to correct, and it may cause pump cavitation.
- ✓ Follow the OEM procedures for starting and warming the excavator hydraulic system. Do not operate the attachment circuit during the warm-up period.
- ✓ After the excavator has reached normal operating temperature, set the engine to idle speed.
- ✓ Attachment must be vertical. Do not allow the tank to run low - have someone watch the oil gauge.
- ✓ Slowly fill the bore end of the attachment cylinder to partially close the jaws.

NOTICE

Do not fully extend or retract attachment cylinder with the first cycles.

Slowly fill the rod end of the attachment cylinder to open the jaws. Use partial strokes extending and retracting, slowly working to full strokes.

Stop and check the excavator hydraulic fluid level again to be sure there is still sufficient fluid. Service as required. Note: hydraulic fluid level should be checked with the attachment jaws open (cylinder retracted).

Cycle the attachment jaws five or six strokes before increasing to full operating pressure.

GENERAL OPERATION INSTRUCTIONS

Follow all rules and procedures outlined in the Operational Safety section of this manual.

Use the attachment only as intended, in approved applications, as set forth in this manual.

Do not allow attachment, exposed cylinder rod or hoses to come into contact with any obstacles, buildings or the excavator.

The attachment is not intended to crush or break objects or structures by swinging or dropping the attachment.

Start-up

During initial operation and any time jaw maintenance has been performed, process thin and lighter material first to work-harden wear areas, developing a harder, more durable edge. This is also the most effective time to process materials such as sheet metal or wire. The new or repaired edges will cut more efficiently and be less likely to jam material between the blades.

NOTICE

When operating in temperatures below freezing, it is also important to process light materials first. This allows the attachment's structural material to warm-up, preventing thermal cracking.

Efficient and Productive Operation

Operators should become accustomed to performing work in the most proficient manner possible.

When cutting, build up and cut out of small piles, keeping the surfaces of the attachment chin plate and upper jaw out of the dirt as much as possible. Dirt is much more abrasive than steel and needlessly increases build-up and hard-surfacing time and intervals.

It also helps to give yourself enough room to keep out of the way of other personnel and machines. Material should be picked from a pile and swung to the side and cut in a new area. This prevents redundant cutting of the same pieces and allows for the newly prepared material to be loaded out with another material handling machine.

Material processing areas should be as close as safely possible to the location for loading materials for transportation. Less time spent processing, loading and transporting materials greatly affects operational costs and productivity and dramatically reduces man hours, fuel costs and wear on equipment.

Operators should develop the habit of assessing materials to be processed and visualizing a starting and finishing point to use the fewest cuts possible. Excessive moving, positioning and handling cost time and money. Bringing the jaws to full open, when only partial jaw open is needed for a cut, wastes time and fuel, slows other excavator functions as well as causes needless wear to hydraulic components, hoses and o-rings. More efficient processing will extend the life of the attachment.

COMMON OPERATIONAL CONCERNS

Cutting Larger Materials

When cutting larger materials the attachment jaw stalls just before cutting.

Suspend the material on the prepared pile, open the jaw and position the material as close to the throat as possible. Without pushing down on the material with excavator force, rapidly close the jaw on the material. Using the speed of regeneration can improve performance when cutting larger materials.

Chatter While Cutting

If the attachment starts to chatter while cutting, back out of the cut and reposition at a different spot.

Chattering is an indication that material is jamming between the piercing blades and guide blades or between the upper and lower cutting blades. This indicates that blade maintenance needs to be performed immediately. Worn blades and improper blade gaps are usually the cause.

Insufficient piercing blade gaps will also cause this, as the blades and parent material of the jaws are subject to thermal expansion from cutting friction. The tighter the blades run, the hotter they get and the more they expand. Piercing blades and guide blades are the most susceptible to this and will show blue streaking on their corresponding faces. In some cases, they will get so hot that surface cracks and spidering occur. As this happens, it will spread the lower jaw and increase gaps between the primary and secondary blades, causing thin material to jam between them.

Another key area to watch is the opening between the guide blades. Be aware of material that may get into this opening before the piercing blade moves into this space, as it will be wedged between the piercing blades and guide blades.

Most jamming conditions can be prevented if the operator pays attention to the sound and vibration that is associated with a jam. Remember that because of the rod-to-bore ratios of displacement on the attachment's hydraulic cylinder piston, the attachment has half the force on jaw open compared to jaw close. So if the attachment is jamming while closing, it won't have enough retract force to open.

MAINTENANCE SAFETY

Only trained and authorized persons should perform maintenance on the attachment. To be qualified, you must understand the instructions in this manual, have training, and know the safety rules and regulations of the job site.

Do not alter the physical, mechanical or hydraulic operation of the attachment. Doing so may cause a dangerous situation for yourself and those around you and will void the warranty.

Do not attempt repairs you do not understand. If any questions arise regarding a safety or maintenance procedure, contact Genesis or your Genesis dealer.

Read this entire manual. All personnel must understand the maintenance and safety procedures.

Use factory authorized parts. The use of unauthorized parts may compromise safety, performance and durability of the attachment and may void the warranty.

Follow the daily checklist and maintenance schedules in this manual. Extreme conditions may dictate shorter maintenance intervals.

Do not exceed bolt torque specifications. See the Genesis Fastener Manual.

Do not weld on structural components without consulting Genesis. Doing so may cause structural failure and void the warranty.

Do not operate an attachment without the case-drain line properly installed if the attachment uses a rotation system that requires a case drain. Doing so will cause immediate failure of the rotate motor and gearbox.

Do not work on the attachment before ensuring it will not move. Completely lower the boom to the ground or a rest position and relieve hydraulic pressure.

Never operate poorly maintained equipment. When maintenance is required, repair or replace parts immediately.

Do not operate under unsafe conditions. If an unsafe condition arises during operation, immediately shut down the equipment and report the situation to the proper authority.

MAINTENANCE SAFETY

Do not work on any hydraulic lines or components while they are pressurized. Escaping hydraulic fluid can penetrate the skin, causing serious injury or death. Relieve pressure before performing maintenance. Keep hands and body parts away from pin holes and nozzles, which eject fluids under high pressure. Use a piece of cardboard to search for leaks.



If fluid is injected into the skin, seek medical assistance immediately from a doctor familiar with this type of injury.

NOTICE

See “Use Care with Hydraulic Fluid Pressure”, page 13

Hydraulic oil becomes hot during operation. Do not let hydraulic oil or components contact skin, as it could cause severe burns. Allow hydraulic components to cool before working on them. Use protective clothing and safety equipment.



Remove paint before welding or heating. Hazardous fumes/dust can be generated when paint is heated by welding, soldering or using a torch. Do all work outside or in a well ventilated area and dispose of paint and solvent properly.

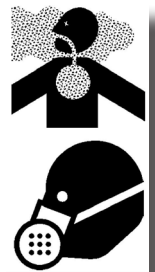

When sanding or grinding paint, avoid breathing the dust. Wear an approved respirator. If you use solvent or paint stripper, remove stripper with soap and water before welding. Remove solvent or paint stripper containers and other flammable materials from area. Allow fumes to disperse at least 15 minutes before welding or heating.

Avoid fire hazards. Keep the area clean. Remove all flammable materials from the area during any welding or heating process. Have a fire extinguisher nearby and know how to use it.



Never substitute pins or bolts. Use factory supplied pins. Replace all bolts with the same size and grade. Failure to do so may cause serious injury or death.

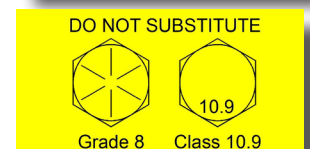

MAINTENANCE SCHEDULE

Performing scheduled maintenance will promote safe, reliable operation of your attachment. Inspect and grease components every eight hours of operation, as indicated in the following checklist. Use maintenance procedures described in this manual. If you are not able to safely and competently perform these procedures, have a Genesis dealer perform them.

After the first **80 hours** of operation, check all bolts, including slewing ring bolts.

Change gearbox lube after first **50 hours** of operation.

NOTICE

Extreme operating conditions may require shortened maintenance intervals.

Operating the attachment with excessively worn blades, blade gaps or main bearings could lead to premature cylinder failure. Excessive deflection of the upper jaw from these conditions will transfer side loading forces to the cylinder piston and barrel, which causes undue pressure on the wear bands of the piston, potentially resulting in cylinder failure.

Pounding the upper jaw lever arm or cylinder clevis on the ground or a hard object to clear a material jam can cause high pressure hydraulic spikes to the attachment and excavator which can damage the hydraulic system components. These spikes can damage the cylinder piston seals, which will allow oil to bypass and wash out the piston wear bands, resulting in premature and possibly catastrophic system failures.

Scheduled Maintenance

- ✓ Replace slewing ring bolts every 2000 hours.
- ✓ Check gearbox lube every 250 hours. Change annually.
- ✓ Replace regeneration valve components every 4000 hours.
- ✓ Reseal cylinder every 4000 hours.

MAINTENANCE SCHEDULE

Eight-Hour Checklist

Inspect:

- Bolts - check for loose bolts, replace if damaged
- Fittings and hoses for damage or leaks
- Bracket pivot for wear and pin retainers
- Cylinder pivot for wear and pin retainers
- Entire attachment for cracks (visual check)

Grease:

- Bracket pivot
- Bracket cylinder
- Attachment cylinder butt (two pumps per fitting)
- Attachment cylinder rod (two pumps per fitting)
- Main shaft/pivot (both sides)
- Rotation bearing (four locations)
- Rotation head (two locations)

Jaws and Blades:

- Check gap between guide blade and upper left-hand tip blade
- Check blade fuses
- Check blade tolerance
- Check blade edge radius
- Check gap between upper tip blades and razor blade
- Check for loose or damaged bolts
- Build-up and hard-surface as required

LUBRICATION POINTS



Shut off excavator and disable hydraulics per OEM instructions before greasing.

For normal conditions above 32°F (0°C), use a lithium-based, premium grade 2 extreme-pressure grease. For temperatures below 32°F, use a grade 0 grease.

Do not use grease containing Molybdenum (Moly).

Genesis GLG-2® anti-wear, extreme-pressure lithium grease, PN 6302601, is recommended for all temperature conditions.

The jaws must be closed for access to all grease fittings. Grease all fittings every eight hours of operation (see eight-hour checklist).

After greasing the rotation bearing, rotate the attachment through two full rotations.

Grease locations:

1. Bracket pivot
2. Bracket cylinder
3. Attachment cylinder butt
4. Attachment cylinder rod
5. Main shaft/pivot (both sides)
6. Rotation bearing (two locations)
7. Rotation head (two locations)

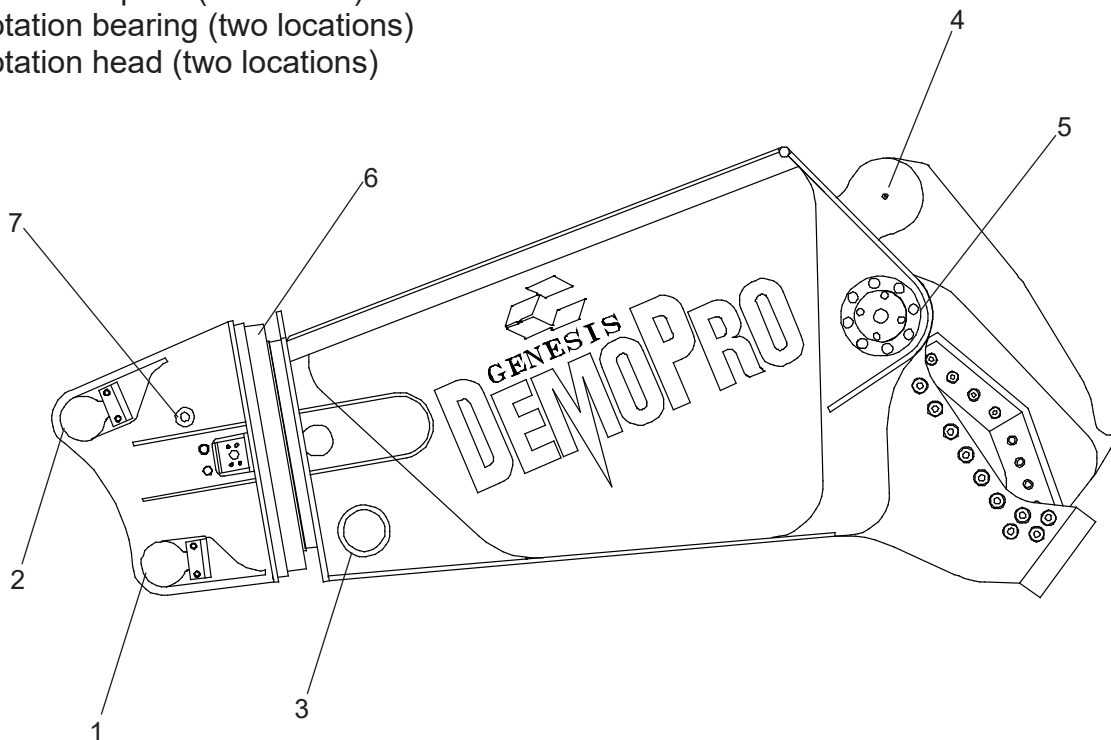

BOLT TORQUE SPECS

**Bolt torque specs and thread treatment procedures can be found in the
Genesis Fastener Manual.**

genesisattachments.com/manuals

JAW AND BLADE MAINTENANCE

Blade and blade seat maintenance greatly affects performance. To maximize cutting performance and optimize replacement part life, follow this specific sequence of checks, adjustments and maintenance.

1. Guide Blade - rotate, shim to tolerance, and replace when worn
2. Upper Left-hand Tip Blade - replace or rebuild when worn
3. Blade Fuses - replace if worn, cracked or damaged
4. Upper Right-hand Tip Blade - replace or rebuild when worn
5. Upper Tip Blade - replace or rebuild when worn
6. Upper Primary Blade - rotate to use two cutting edges, then replace
7. Lower Blades - rotate to use two cutting edges, shimming when necessary, then replace
8. Razor Blade - rotate to use four edges, then replace
9. Jaw hard-surfacing - build-up and hard-surface as needed.

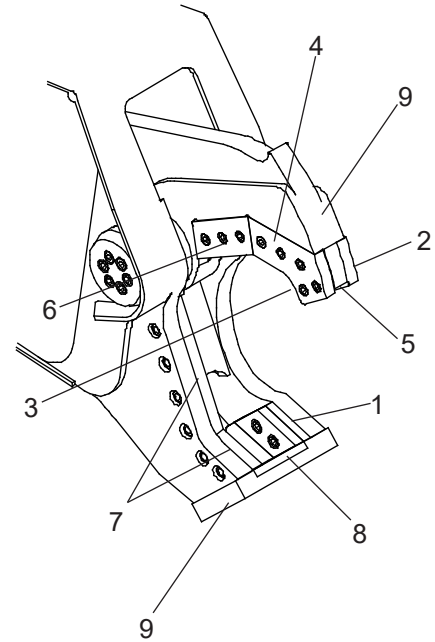

Blade Bolts

Visually check for loose or broken bolts daily. Retorque loose bolts to the specifications listed in the Genesis Fastener Manual torque chart. Replace broken bolts.

GUIDE BLADES

When necessary, shim the guide blade to maintain the gap within 0.005" to 0.020".

The top and bottom of the blade may be shimmed differently to maintain squareness. The difference should not be greater than 0.050" (1.3mm).

Rotate the guide blade when shim thickness exceeds 0.050" (1.3mm). Replace the guide blade when more than 0.100" (2.5mm) of shims are required.

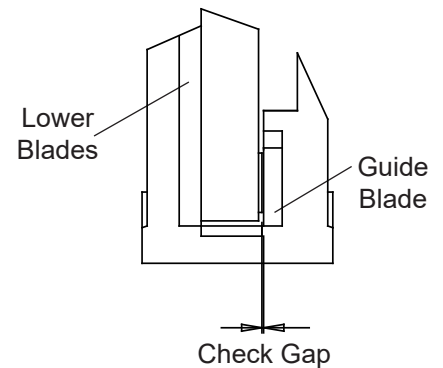

Shimming

Slowly close the jaw so the tip blade begins to bypass the guide blade. Stop the jaw and check the gap between the guide blade and tip blade.

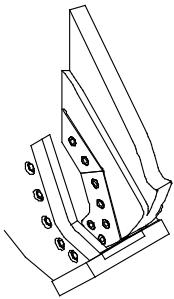

Cycle slowly, stopping at several points along the tip blade to check the gap each time.

Shim the guide blade as needed to keep the gap within the 0.020".

To install shims, loosen blade bolts and slide shims between the guide blade and guide blade seat.

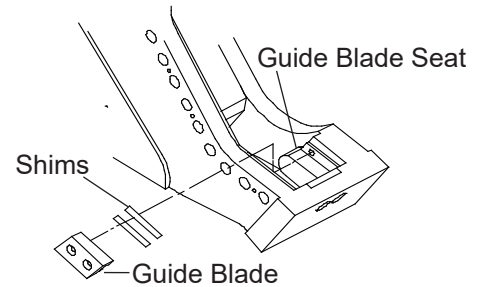

Retorque bolts and recheck the gap.

Rotation

Remove the blade bolts, guide blade and shims. Rotate the blade end-for-end. Reinstall and torque bolts. Check gap; shim if required.

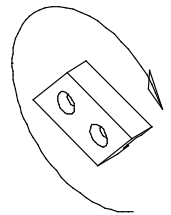

Replacement

Remove guide blade and shims. Install new guide blade with no shims. Check blade gap and shim as needed. If more than 0.100" of shims are needed, upper tip blade must be rebuilt or replaced.

UPPER TIP BLADES

Maintain tip blades to maximize productivity and safe operation. An excessive gap results in a great reduction in piercing and cutting efficiency and contributes to material jamming.

The front blades should be checked for wear daily. Replacement or rebuild should be performed every 40-80 hours depending on the application.

Slowly cycle the jaws until the upper blades pass the top edge of the razor blade.

With a tape measure, check the gap. Acceptable gap is 3/8"-3/4" (10-19mm).

Check the condition of the blades with a straight edge or square.

Check the profile along the blades.

The upper tip blades cannot be rotated. When the cutting edge has worn to a 1/8" (3mm) radius, they must be replaced or rebuilt as explained in the build-up and hard-surfacing procedures in this manual.

After installation of new or rebuilt tip blades, the upper jaw face should be built up flush with the blades to prevent the blades from getting caught and being ripped off when the upper jaw opens. See the build-up and hard-surfacing sections of this manual.

After installation or rework of upper tip blades, remove the guide blade and follow the Guide Blade Shimming procedure before cycling the jaw.

Blade Fuse

The blade fuse is an important safeguard to the front blade, blade seat and blade bolts. The blade fuses must be inspected for damage any time the blades are removed for rebuild or replacement. If cracks are found or the fuse is deformed, it must be replaced.

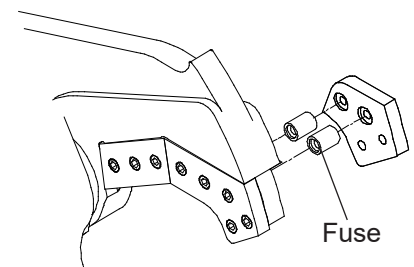
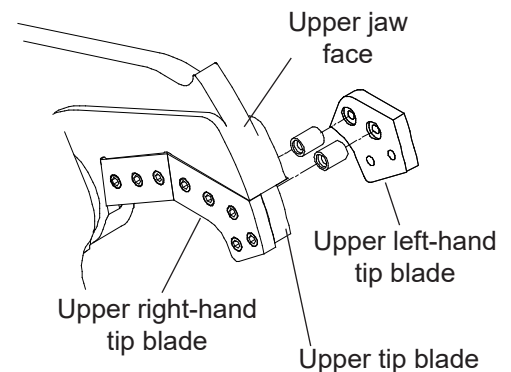
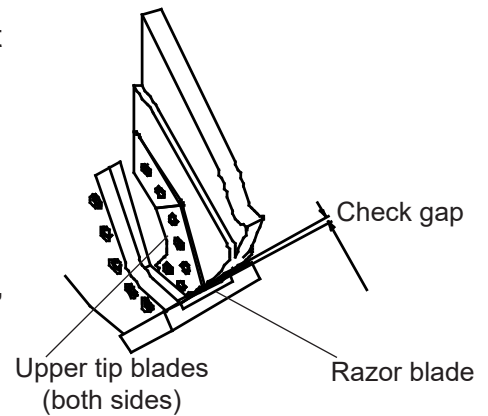

CUTTING BLADES

Proper maintenance of the cutting blades is required for optimal performance. Blade rotation extends blade life and improves cutting performance. Shimming to maintain blade tolerances helps prevent jamming. Dull blades make the excavator hydraulic system work harder and may cause structural damage to the attachment.

Rotate blades as described in this manual.

Always use Genesis-approved blades. Blades that do not meet Genesis specifications can cause major problems, and using them may void the warranty.

Before performing any blade maintenance, read, fully understand and follow these safety rules.

- Wear personal safety equipment including gloves, safety glasses, safety boots and proper clothing.
- Safe blade maintenance requires two people - one to steady the blade while the other loosens the bolts.
- Blades are heavy and may fall out of blade seat if not adequately supported. Bystanders must stand clear.
- Never strike a blade with a hardened steel tool. The blade may fragment, creating sharp flying objects.

Removal

Loosen the bolts, on one blade at a time, enough to loosen the blades.

If blades remain tight, insert a 7/16" drift pin into the through-hole on the lower jaw. Tap the drift pin with a hammer until the blade is loose.

Carefully remove bolts and blades.

Do not remove the adjustment plates from the lower jaw. These plates are custom-machined for your attachment and need only be replaced when damaged.

Inspect the top of each adjustment plate for burrs, nicks or other imperfections that may prevent proper seating of the blades and cause errant blade gap readings. Clean adjustment plates as necessary.

Do not grind on blade seat areas.

CUTTING BLADES

Rotation

Inspect blades every eight hours of operation. Retorque loose bolts and replace broken bolts. Rotate blades when the cutting edges are worn to a 1/8" (3mm) radius.

Recommended rotation intervals are approximately 40-80 hours of operation for a two-blade configuration, depending on the material being processed. Thin materials may require shorter rotation intervals. Blades must be replaced when all four edges are worn to 1/8" (3mm) radius.

Note: On models GDP 450 and GDP 900, the lower secondary blade may be exchanged with the guide blade to use two additional edges on each blade.

Upper Blade Rotation
Rotate primary blade end-for-end

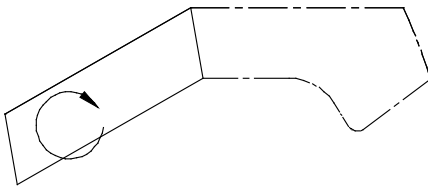

Lower Blade Rotation GDP 450-650
Rotate both blades end-for-end

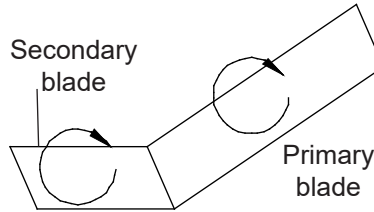

Lower Blade Rotation GDP 900
Rotate all blades end-for-end

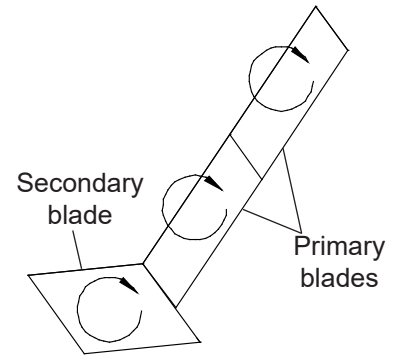

The following chart may be copied and used to track blade rotation.

40 - 80 Hours	Date	Hour Meter	Performed By
Installation			
Rotation			

CUTTING BLADES

Blade Gap

After each blade rotation, shim lower blades to eliminate any excess gap between upper and lower blades. Do not shim the upper blades. Use only Genesis shim kits.

The optimum gap is 0.005" to 0.010" and should not exceed 0.020".

Blade Gap Measuring Procedure

Slowly close jaws until blades begin to bypass. Check blade gap with a feeler gauge.

Continue closing the jaws and checking the gap along the entire length of the blades.

Note: The gap will be consistent along the entire length of the blades if they have been rotated correctly.

If blade gap reaches 0.020", shim lower blades. Replace blades when gap exceeds 0.115" or when more than 0.100" of shims are required to maintain gap.

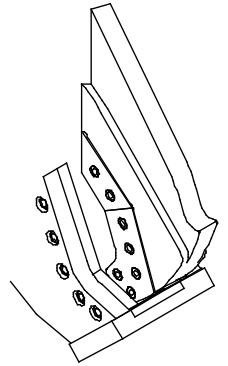

Shimming

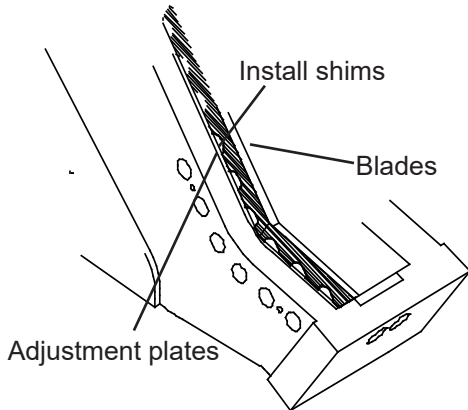

Loosen blade bolts.

Install shims between blades and adjustment plates as needed to bring into tolerance.

Torque bolts to spec and recheck tolerances.

Do not use more than 0.100" of shims.

RAZOR BLADE

Check the razor blade for wear every eight hours of operation. Rotate when worn. The first rotation is 180°, bringing the bottom edge to the top. The second rotation is 90°, bringing a side edge to the top. The third rotation is 180°, using the final edge.

After rotation, check gap between razor blade and upper tip blades. If gap exceeds maximum tolerance after new piercing blades have been installed, the razor blade must be replaced. Do not shim the razor blade.

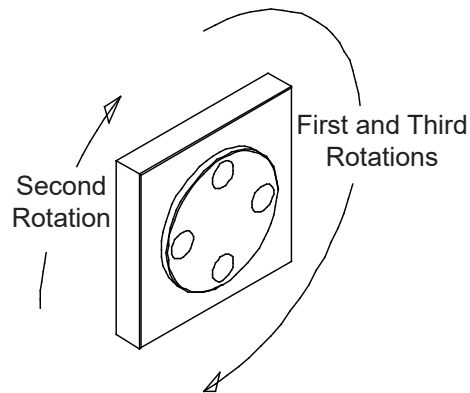

GENERAL WELDING GUIDELINES

Build-up and hard-surfacing are welding procedures that protect the parent material of the jaws and keep the blades in good adjustment. Build-up is the welding procedure that restores the jaws to their original shape. Building up the jaws helps protect the blades and increases the life of the attachment. Hard-surfacing is the welding material added over the parent material (or build-up material) to create a wear-resistant surface.

Welding should not be performed until the jaws are work-hardened. Work-hardening can take up to 80 hours. However, jaws must not wear lower than the height of a new blade. If either jaw wears down lower than blade height, immediately stop operating the attachment and perform build-up and hard-surfacing as described in the following pages of this manual.

When welding around blade seats or the piercing tip tang area, maintain the factory machined seat radius. If the rounded grooves are welded up, use a die grinder with a carbide tool to recut these areas to their original profile. Leaving a squared edge will eventually cause structural cracking. The radius provides a broader area to absorb structural stress.

Welding Ground Clamp

Disconnect all battery ground cables or shut off master battery switch, if equipped. Failure to do so may cause excavator electrical problems, including permanent damage to onboard computer systems.

Connect ground clamp as close as possible to the area being welded without allowing current to pass through the pivot group, cylinder pin, cylinder, swivel, motor, gearbox or slewing ring.

If you are welding on the lower jaw, connect weld clamp to the lower. If you are welding on the upper jaw, connect to the upper but not to the cylinder clevis. If needed, weld a piece of steel to the area for the grounding clamp and cut the piece off when welding is completed.

Welding Rules

Before you begin:

- Remove adjacent blades, as preheating and welding may cause blade damage.
- Wearing an approved respirator, grind the area to clean it, removing all existing hard-surfacing.
- Preheat area to 350° F (177° C). Maintain this temperature throughout the procedure. Do not exceed 450° F (232° C) interpass temperature.

During welding:

- Always grind and weld with the grain of the material.
- Peen each weld pass to relieve stress and harden the welds.
- Do not undercut the ends of the welds.
- Do not start or stop welds directly above a bolt hole or in the apex of the jaw.

After welding maintenance is complete:

- Cover the area with a heat blanket and allow it to cool slowly, approximately eight hours.
- Do not put the attachment into operation until the welds have been allowed to cool.

HARD-SURFACING

Do not apply hard-surfacing directly to the parent material as this could cause toe cracking, and the hard-surfacing will break away.

Procedure:

Follow the General Welding Guidelines and Rules.

Apply a single pass stringer bead pattern, with the grain, using E7018 electrode. Peen each pass.

Do not apply a stringer directly on the edge. Start the first pass 1/4" from the edge.

Stagger the ends of the stringer welds so they do not end in a straight line.

Cap each stringer bead with one pass of GenWire or GenRod to hard-surface. Do not apply more than two layers of hard-surfacing. Peen each pass.

Grind the ends of all stringer welds with the grain to taper 1" to 1-1/2" (25 - 38 mm) to the parent material.

See the following page for hard-surfacing illustrations and instructions specific to each area of the jaws.

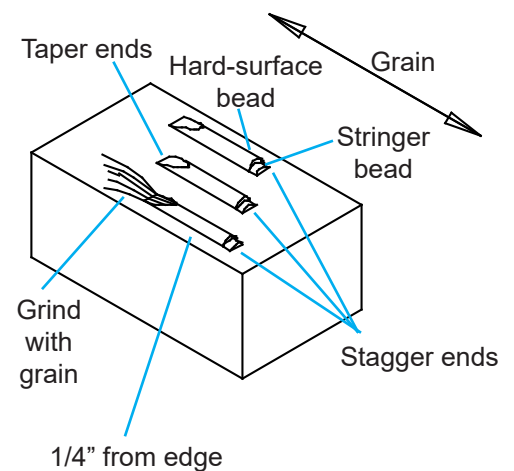

Upper Tip Blades

Blade life may be extended by hard-surfacing. However, a rebuilt cutting edge is not as durable as the original, leading to more maintenance time for less output.

Remove blades prior to rebuilding.

Hard-surfacing should be performed when the cutting edges are rounded to 1/8" (3mm). Build-up is not required under the hard-surfacing on blades. If the blade is rounded to the point of requiring more than two layers of hard-surfacing, it must be replaced.

Do not hard-surface the highlighted edges shown in the drawing, which are fitted to the blade seats or other blades. Improper fit will cause damage.

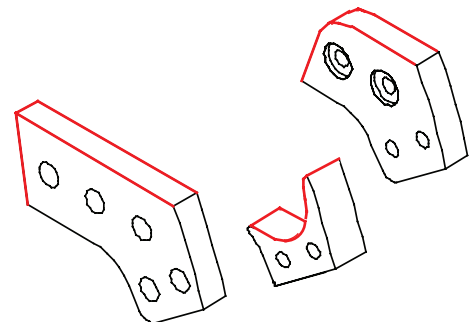

HARD-SURFACING

Upper Tip Blade Rebuild Procedure

Using a square, determine the original blade profile (A).

Apply hard-surface to the edges (B).

Grind edges square (C). Do not exceed original blade width.

After installation or rebuild of front blades, the upper jaw face should be built-up flush with the blades to prevent the blades from getting caught and being ripped off when the upper jaw opens.

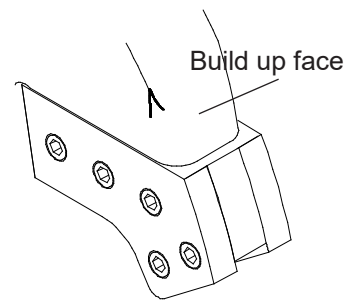
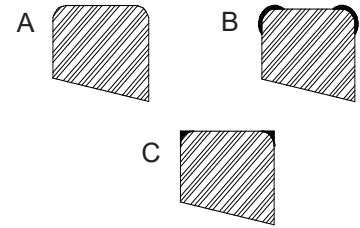

HARD-SURFACING PATTERNS

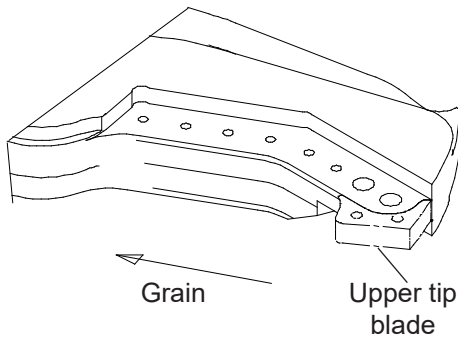

Upper Jaw

Single passes approximately 1" apart. Begin just behind the upper tip blade and continue toward the throat. Use three to five stringers, depending on the model of the processor. Note: Do not apply stringers in the area of the upper tip blade.

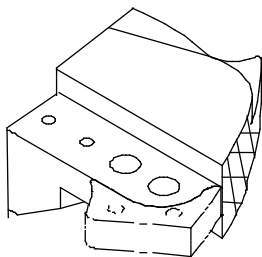

Upper Jaw Face

Crosshatch the upper jaw face with stringer beads at 45° angles to form 1" squares. Begin above the upper tip blade to approximately half way up the face. Note: Do not apply stringers in the area of the upper tip blade.

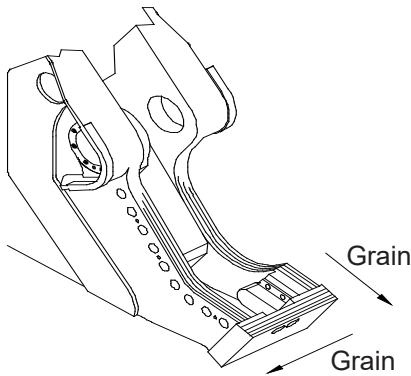

Lower Jaw

Single passes approximately 1" apart. Work across the top of the chin plate and along the lower jaw toward the throat. Use two to three stringers, depending on the model of the processor.

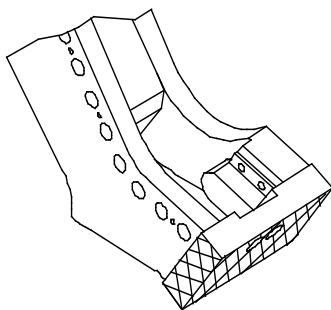

Lower Jaw Chin

Crosshatch the chin plate with stringer beads at 45° angles to form 1" squares.

HYDRAULIC/ROTATION MAINTENANCE

Hydraulic Requirements

Operating the attachment below the recommended flow and/or pressure range will adversely affect performance and may damage the rotate motor.

Operating the attachment above the recommended flow and/or pressure range may damage the attachment and its hydraulic components.

Model	Flow	Pressure
450	50 - 80 GPM 189 - 303 LPM	4500 - 5500 PSI 310 - 380 Bar
650	60 - 120 GPM 227 - 454 LPM	
900	80 - 120 GPM 303 - 454 LPM	
1200	85 - 125 GPM 322 - 473 LPM	

Rotation Valve Input

For cooler and more efficient hydraulic system operation, set the input pressure and flow as indicated in the chart. The attachment rotation speed should be 3 - 4 RPM. Exceeding 4 RPM will result in rotation component damage.

The maximum case drain pressure measured at the shear while rotating and cycling the jaws must never exceed 40 PSI. Pressure increases during cold-weather operation.

Model	Flow	Pressure
450	3 - 5 GPM 11 - 19 LPM	1700 - 1900 PSI 117 - 131 Bar
650 & 900	7 - 11 GPM 26 - 42 LPM	1950 - 2150 PSI 134 - 148 Bar
1200	8 - 12 GPM 30 - 45 LPM	

Rotation Valve Settings

When checking the crossover relief valve settings, put pressure gauges on both diagnostic ports. Subtract the lower reading from the higher reading.

Model	Flow	Pressure Reducer	Crossover Relief
450	3 GPM 11 LPM	1700 PSI 117 Bar	2100 PSI 145 Bar
650 & 900	7 GPM 26 LPM	1950 PSI 134 Bar	2200 PSI 150 Bar
1200	8 GPM 30 LPM		

GENFLOW REGENERATION VALVE

Your regeneration valve features a GenFlow adjustment cartridge to control the timing of the shift between speed and power modes. When the cartridge is properly set, the jaw closes rapidly until it begins to cut. The valve shifts, slowing jaw close and increasing power. You may hear a squeal or hiss as this happens. The valve shifts back into speed mode after the cut is complete.

The cartridge is factory-set, turned out approximately seven turns. This setting is appropriate for most applications. However, the cartridge may be custom-set if necessary.

Regeneration valve adjustment is a two-person job. The ground crew must be in full view of the operator at all times and must stand clear of the jaws when cycling. Check the cycle time when the hydraulic fluid is warmed up, timing from full open to full closed and back to full open. To increase power, turn adjustment cartridge out (counter-clockwise). To increase speed, turn in (clockwise).

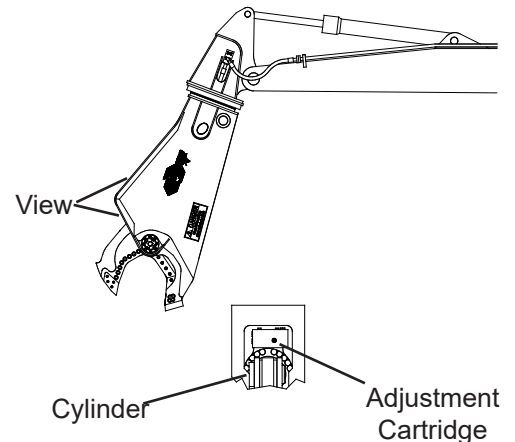

Shut down and disable hydraulics before adjusting the cartridge.

Loosen the lock nut with a 17mm socket.

Turn cartridge 180° (half-turn) with a 5mm allenhead socket.

Tighten lock nut.

Check the cycle time.

Repeat until the preferred balance of speed and power is met. Final adjustment may require less than half-turn.

SLEWING RING MAINTENANCE

Visually check slewing ring (rotation bearing) bolts every eight hours of operation. Do not reuse or re-torque these bolts. Loose or broken bolts, along with the bolts on either side, must be immediately replaced.

The bolts that secure the slewing ring are critical for safe attachment operation. Improper torque may cause the bolts to fail and the attachment to break free, which may result in serious personal injury and equipment damage. Improper torque will also cause uneven slewing ring wear.

Rotating components must be greased daily. Grease fittings are located on the outside of the slewing ring and on the inside of the rotating head assembly. Grease locations are marked with decals.

Grease each fitting and then rotate the attachment two full rotations.

For normal conditions above 32°F (0°C), use a lithium-based, premium grade 2 extreme-pressure grease. For temperatures below 32°F, use a grade 0 grease. **Do not use grease containing Molybdenum (Moly).**



Genesis GLG-2® anti-wear, extreme-pressure lithium grease, PN 6302601, is recommended for all temperature conditions.



Stand clear when the attachment is being rotated. Always stay in clear view of the operator.

GEARBOX MAINTENANCE

Planetary Gearbox Lubrication

Proper lubrication is critical to ensure performance and long life of the gearbox. Change gearbox lubricant after the initial 50 hours of operation. Check gearbox lubricant every 250 hours. See table for recommended grades and lubricant change-out schedule based on climate.

Low Temp.	Grade	Change
5°F (-15°C)	SAE 80W-90W	500 hours or annually
-50°F (-45°C)	Synthetic ISO 150	1000 hours or two years

Gearbox Lube Change-out Procedure

Position attachment so gearbox is level (horizontal) at a convenient working height.

Remove rotator access cover and place an oil drain pan under gearbox drain plug.

Remove bottom drain plug and top fill plug.

Once drained, replace bottom drain plug.

Add 32 ounces (950ml) of gearbox lubricant through fill plug. Do not overfill.

Replace fill and inspection plugs. Reinstall access cover.

Properly dispose of used lubricant.

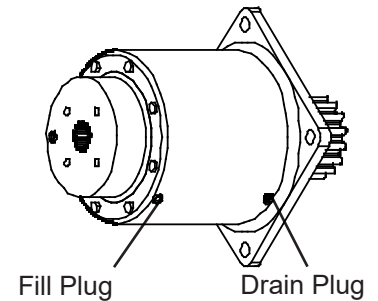

TROUBLE-SHOOTING GUIDE

Attachment

Symptom	Possible Cause	Possible Solution
Lacks power	Circuit not getting full pressure from excavator	Check hydraulic pressure at port block
	GenFlow cartridge needs adjustment	Make adjustments following procedure listed in this manual
	Attachment cylinder or swivel bypass	Check for bypass and replace seals if needed
Poor cutting	Material size is beyond attachment appetite range	Consult the factory
	Worn blades	See the jaw and blade maintenance sections of this manual
	Excess blade gap	
	Excess back pressure on return side of cylinder	Check excavator main control valve
Poor piercing	Excessive wear at upper tip blades and/or razor blade	See the jaw and blade maintenance sections of this manual
Slow jaw cycle time	Genflow cartridge needs adjustment	Make adjustments following procedure listed in this manual
Material jamming	Excess blade gap	See the jaw and blade maintenance sections of this manual
	Worn blades	
	Excess gap between upper tip blades and guide blade	
	Worn upper tip blades	
Slow jaw cycle in one direction	Excess back pressure on return side of cylinder	Check excavator main control valve
Jaw drifts closed or can be pushed closed	Excavator control valve	Check excavator main control valve
	Processor cylinder or swivel bypass	Check for bypass and replace seals if needed

TROUBLE-SHOOTING GUIDE

Rotator

Symptom	Possible Cause	Possible Solution
Does not rotate	Blown fuse	Replace fuse
	Electrical problem	Test for 24V at plugs on directional valve while depressing footswitch
	Incorrect pressure settings	Set pressures
	Faulty components	Contact Genesis to replace valve
Does not rotate in one direction	No electrical power to one side	Test for 24V at plugs on directional valve while depressing footswitch
	Faulty directional control valve	Check if directional control valve shifts both ways while actuating footswitch in both directions
	Faulty cartridge	Contact Genesis to replace valve
Rotator chatters	Electrical short	
	Pressure settings too high	Set pressures
	Power to both rotation solenoids at the same time	Test for 24V at plugs on directional valve while depressing footswitch
Rotates faster in one direction	One flow control cartridge set higher than the other	Set flow control
Rotates too fast or too slow	Flow control out of adjustment	Set flow control
Rotation speed changed from original setting	Jam nut loosened on rotation valve	Check jam nuts on rotation valve; set pressures
	Faulty cartridge (contamination)	Replace cartridge
	Faulty directional control valve	Replace valve
	Pressure set too low	Set pressures

WARRANTY

Claim Procedure

Notify the Genesis Service Department of the potential warranty claim prior to making the repair. Digital pictures are very helpful for diagnosing problems and recommending repairs.

Contact the Genesis Service Department before making alterations, changes or repairs to any component that is going to be considered for warranty. Not doing so will void all Genesis warranty consideration.

The Genesis Service Department will issue an authorization number to track the repair costs, outgoing parts, and/or defective parts returning to the factory.

Replacement parts must be ordered using a purchase order number. Shipping is standard ground. Overnight shipping is available by request, and Genesis will not cover the shipping charge.

When the repair is complete, submit an invoice to the Genesis Service Department within 30 days. Include itemized internal labor reporting, parts lists and invoices for outside contractors. Reference the authorization number on all invoices.

When returning parts for warranty consideration, include a copy of any related Genesis paperwork along with any other necessary documentation to ensure proper processing and credit. The Genesis Service Department will provide the necessary forms.

Your account will be credited when the warranty claim is accepted.

Blade Warranty

Standard warranty on blades will only be considered on the first edge, and wear on the edge must be 1/8" radius or less. Genesis does not warranty cutting blades that are cracked or broken from top to bottom (perpendicular to the long edge of the blade). Genesis also does not cover fasteners, the labor to replace wear components or collateral damage, such as blade seats, from broken blades, the piercing blade tang or adjustment plates.

Please direct any questions to the Genesis Service Department: 715-395-5252

PARTS ORDER POLICY AND PROCEDURE

Parts Orders Should Include

- Purchase order number
- Model and serial number of attachment
- Part number and quantity needed
- Shipping and billing address
- Method of shipment or required delivery date

Placing Orders

Orders may be placed by phone or e-mail. To e-mail an order, use the form on the following page or your purchase order form. Contact information is located at the front of this manual.

Part Numbers

Part numbers are listed in a separate Parts Manual or, if included, the Parts section of this manual. Contact the Genesis Parts Department with questions regarding part numbers, availability and pricing.

Shipping

All orders will be shipped best way surface unless an alternate shipping method is requested. Shipping charges are not included in the purchase price of parts.

Invoices

All invoices are due upon receipt. Any accounts with invoices open beyond 60 days are subject to review and may be placed on C.O.D. status without further notice.

Returns

Many unused Genesis parts may be returned with proper documentation. Return shipping is the responsibility of the purchaser. Credit will be issued upon return, less a 25% restocking fee. Documentation is required for credit of returned parts. Contact the Genesis Service Department at 715-395-5252 for an RGA (Return Goods Authorization) number and form. An RGA must accompany every return. Items shipped without an RGA may be returned to sender.

Warranty Returns

All parts returned to Genesis for warranty consideration must be returned with a completed RGA (Return Goods Authorization) provided by the Genesis Service Department. The form needs to be completed in its entirety, including any additional information requested by the Service Department. Return shipping is the responsibility of the sender and will be credited upon claim approval. A determination to accept or deny the claim will be made based upon the information available to Genesis. Warranty on purchased parts other than wear components is 6 months. Genesis does not cover labor costs to replace purchased parts replaced under warranty. There is no warranty period on wear parts or components.

TOOL LIST

The following is a list of tools available for purchase from Genesis. This list may not include every tool used for this attachment, such as those that would also commonly be used for maintaining an excavator.

Part Number	Description
6900001	Service tool kit - includes part numbers 6900002 through 6900020
6900002	1-1/2" 12-point socket, 1" drive
6900003	1-5/16" 12-point socket, 1" drive
6900004	5/8" impact hex bit socket, 3/4" drive
6900005	3/4" impact hex bit socket, 3/4" drive
6900006	3/4" drive female to 1" drive male adapter
6900007	1-1/4" combo wrench
6900008	Jet needle scaler
6900009	17mm socket, 3/4" drive, metric impact
6900010	Torque multiplier, 2000 ft/lb
6900011	3/4" drive torque wrench, 600 ft/lb
6900012	26" male/female ratchet, 1" drive
6900013	30" ratchet, 1" drive
6900014	5/16" LA hex key
6900015	1-5/16" combo wrench
6900016	7/8" combo wrench
6900017	1-1/8" combo wrench
6900018	40mm 6-point impact socket, 3/4" drive
6900019	46mm 6-point impact socket, 3/4" drive
6900020	Tool box
6900021	7/8" impact hex bit socket, 3/4" drive
6900022	1-1/2" 6-point socket, 1" drive
6900023	7/8" impact hex bit socket, 1" drive
6900024	36mm 6-point impact socket, 1" drive



GENESIS®

The Promise of Performance.

CONTACT INFORMATION

Genesis Attachments

1000 Genesis Drive
Superior, WI 54880 USA

Toll Free: 888-SHEAR-IT
(888-743-2748)

Phone: 715.395.5252

E-mail:
info@genesisattachments.com

Europe/Africa/Middle East Genesis GmbH

Teramostrasse 23
87700 Memmingen, Germany

Phone: +49 83 31 9 25 98 0

Fax: +49 83 31 9 25 98 80

genesis-europe.com

E-mail:
info@genesis-europe.com

Asia Pacific Representative Office

24 Upper Serangoon View #12-28
Singapore 534205

Phone: +65 9673 9730

E-mail:
tchoo@genesisattachments.com

Central America & Colombia

Cra 13A #89-38 / Ofi 613
Bogota, Colombia

Phone: +57 1 610 8160 / 795 8747

E-mail:
contact@themsagroup.com

View and download all manuals: genesisattachments.com/manuals

Patents: genesisattachments.com/products/patents