



# Versi Pro 15 (GVP 15)

## SAFETY, OPERATOR'S & PARTS MANUAL



## CONTACT INFORMATION

### Genesis Attachments

1000 Genesis Drive  
Superior, WI 54880 USA

Toll Free: 888-SHEAR-IT  
(888-743-2748)

Phone: 715.395.5252

E-mail:  
info@genesisattachments.com

### Europe/Africa/Middle East Genesis GmbH

Teramostrasse 23  
87700 Memmingen, Germany

Phone: +49 83 31 9 25 98 0  
Fax: +49 83 31 9 25 98 80  
genesis-europe.com

E-mail:  
info@genesis-europe.com

### Asia Pacific Representative Office

24 Upper Serangoon View #12-28  
Singapore 534205

Phone: +65 9673 9730

E-mail:  
tchoo@genesisattachments.com

### Central America & Colombia

Cra 13A #89-38 / Ofi 613  
Bogota, Colombia

Phone: +57 1 610 8160 / 795 8747

E-mail:  
contact@themsagroup.com

View and download all manuals: [genesisattachments.com/manuals](http://genesisattachments.com/manuals)  
Patents: [genesisattachments.com/products/patents](http://genesisattachments.com/products/patents)

## PREFACE

To ensure years of safe, dependable service, only trained and authorized persons should operate and service your Genesis attachment. It is the responsibility of the product's owner to ensure the operator is trained in the safe operation of the product and has available this manual for review. It is the responsibility of the operator and maintenance personnel to read, fully understand and follow all operational and safety-related instructions in this manual. The attachment should not be operated until you have read and fully understand these instructions. Always use good safety practices to protect yourself and those around you.

### **Important**

This operator's manual must accompany the attachment at all times and be readily available to the operator.

### **Manual Replacement**

Should this manual become damaged or lost or if additional copies are required, immediately contact any authorized Genesis dealer or the Genesis Service Department at 888-743-2748 or 715-395-5252 for a replacement.

### **Registration Form**

The Warranty Registration Form must be filled out by the dealer or customer and returned to Genesis indicating the date the attachment went into service.

### **Possible Variations**

Genesis cannot anticipate every possible circumstance that might involve a potential hazard as the owner's requirements and equipment may vary. Therefore, the warnings in this publication and on the product may not be all-inclusive, and you must satisfy yourself that the procedure, application, work method or operating technique is safe for you and others before operating.

### **Public Notice**

Genesis reserves the right to make changes and improvements to its products and technical literature at any time without public notice or obligation. Genesis also reserves the right to discontinue manufacturing any product at its discretion at any time.

### **Warranty**

All work or repairs to be considered for warranty reimbursement must be pre-authorized by the Genesis Service Department. Any alterations, modifications or repairs performed before authorization by the Genesis Service Department will render all warranty reimbursement consideration null and void without exception. See page 46 for Warranty Claim Procedures.

Improper operation or improperly performed maintenance may render any warranty null and void.

# TABLE OF CONTENTS

<b>CONTACT INFORMATION</b>	<b>2</b>
<b>PREFACE</b>	<b>3</b>
Important	3
Manual Replacement	3
Registration Form	3
Possible Variations	3
Public Notice	3
Warranty	3
<b>SAFETY STATEMENTS</b>	<b>7</b>
<b>OPERATIONAL SAFETY</b>	<b>8</b>
Read Manual Before Operating or Maintaining the Attachment	8
Personal Protection	8
Know Your Equipment	8
Before Operating	8
Check the Equipment	9
Stability	9
Know the Work Area	10
Starting Procedure	10
Place the Load Safely	10
Safely Operate Equipment	11
Transporting the Attachment	12
Equipment Condition	12
Working Overhead	12
Power Lines	12
Use Care with Hydraulic Fluid Pressure	13
Prioritized Oil Flow	14
Emergency Situations	14
Unsafe Conditions	14
Crystalline Silica Dust	14
Prop. 65 Warning for California Residents	14
Process Material Safely	15
Lift the Load Safely	15
Place the Load Safely	15
<b>ATTACHMENT MARKINGS</b>	<b>16</b>
<b>ATTACHMENT INSTALLATION</b>	<b>17</b>
Dual-Pump Flow	17
<b>ROTATOR INSTALLATION</b>	<b>19</b>
Rotation Circuit - Gear Pump Type	19
Rotation Circuit - Auxiliary Valve on Machine	20
<b>HYDRAULIC START-UP</b>	<b>21</b>
Start-up Procedure	21
Rotation Valve Input	21
<b>GENERAL OPERATION INSTRUCTIONS</b>	<b>22</b>
Start-up	22
Efficient and Productive Operation	22

# TABLE OF CONTENTS

<b>COMMON OPERATIONAL CONCERNS</b> .....	<b>23</b>
Cutting Larger Materials.....	23
Chatter While Cutting.....	23
<b>MAINTENANCE SAFETY</b> .....	<b>24</b>
<b>MAINTENANCE SCHEDULE</b> .....	<b>26</b>
Eight-Hour Checklist.....	26
Long-Term Maintenance.....	26
<b>LUBRICATION POINTS</b> .....	<b>27</b>
<b>JAW SET CHANGE-OVER</b> .....	<b>28</b>
Jaw Removal.....	28
Jaw Installation.....	28
<b>SHEAR JAW SET MAINTENANCE</b> .....	<b>29</b>
Piercing Blades.....	29
<b>PIERCING BLADES</b> .....	<b>30</b>
Replacement.....	31
<b>GUIDE BLADES</b> .....	<b>32</b>
Shimming.....	32
Rotation.....	32
Replacement.....	32
<b>PRIMARY AND SECONDARY BLADES</b> .....	<b>33</b>
Removal.....	33
Blade Bolts.....	33
Rotation.....	34
<b>CRACKER JAW SET MAINTENANCE</b> .....	<b>35</b>
Tooth Replacement Procedure.....	35
<b>GENERAL WELDING GUIDELINES</b> .....	<b>36</b>
Welding Ground Clamp.....	36
Welding Rules.....	36
<b>BUILD-UP</b> .....	<b>37</b>
<b>HARD-SURFACING</b> .....	<b>38</b>
<b>HARD-SURFACING PATTERNS</b> .....	<b>39</b>
<b>GENFLOW REGENERATION VALVE</b> .....	<b>40</b>
<b>GENFLOW REGENERATION VALVE - HOW IT WORKS</b> .....	<b>42</b>
<b>SLEWING RING MAINTENANCE</b> .....	<b>43</b>
<b>TROUBLE-SHOOTING GUIDE</b> .....	<b>44</b>
Jaw Set.....	44
Rotator.....	45
<b>WARRANTY</b> .....	<b>46</b>
Claim Procedure.....	46
Blade Warranty.....	46

# TABLE OF CONTENTS

<b>PARTS ORDER POLICY AND PROCEDURE</b>	<b>47</b>
Parts Orders Should Include	47
Placing Orders	47
Part Numbers	47
Shipping	47
Invoices	47
Returns	47
Warranty Returns	47
<b>PARTS ORDER FORM</b>	<b>48</b>
<b>PARTS</b>	<b>49</b>
Second-Member Mount Upper Head	50
Third-Member Mount Upper Head	51
Stick / Body	52
Shear Jaw Set	53
Cracker Jaw Set	54
Hydraulics	55
Rotation Drive System	56
<b>BOLT TORQUE SPECIFICATIONS</b>	<b>57</b>
<b>THREAD TREATMENT DIAGRAM</b>	<b>58</b>
Mobile Shears	58
Processors	59
<b>PROCEDURES</b>	<b>60</b>
Cleaning	60
Threadlocker	60
Anti-Seize	61
No Thread Treatment	61
<b>BOLT TORQUE SPECIFICATIONS</b>	<b>62</b>
Dry Torque Values	62
Wet Torque Values	62
<b>O-RING BOSS &amp; FLAT FACE O-RING TORQUE SPECIFICATIONS</b>	<b>63</b>
<b>BOLT DRIVE SPECIFICATIONS</b>	<b>64</b>
<b>TOOL LIST</b>	<b>65</b>
<b>CONTACT INFORMATION</b>	<b>66</b>

## SAFETY STATEMENTS



This symbol by itself or used with a safety signal word throughout this manual is used to call attention to instructions involving your personal safety or the safety of others. Failure to follow these instructions can result in injury or death.



This statement is used where serious injury or death will result if the instructions are not followed properly.



This statement is used where serious injury or death could result if the instructions are not followed properly.



This statement is used where minor or moderate injury could result if the instructions are not followed properly.

**NOTICE**

This statement is used where property damage could result if the instructions are not followed properly.

# OPERATIONAL SAFETY

## Read Manual Before Operating or Maintaining the Attachment



Read this manual before attempting to operate the attachment. This operator's manual should be regarded as part of the attachment. For proper installation, operation and maintenance of the attachment, operators and maintenance personnel must read this manual.



## **WARNING**

Serious injury or death could result if appropriate protective clothing and safety devices are not used.

## Personal Protection

Use protective clothing and safety devices appropriate for the working conditions. These may include but are not limited to:

- ✓ Hard hat
- ✓ Safety glasses, goggles or face shield
- ✓ Hearing protection
- ✓ Safety shoes
- ✓ Heavy gloves
- ✓ Reflective clothing
- ✓ Respirator or filter mask



# Safety matters

## Know Your Equipment



Know your attachment's capabilities, dimensions and functions before operating. Inspect your attachment before operating and never operate an attachment that is not in proper working order. Remove and replace any damaged or worn parts.

## Before Operating

- ✓ Warn all others in the area that you are about to start operation.
- ✓ Perform the Check the Equipment steps outlined in this manual.
- ✓ Check underneath and around the machine. Make sure all personnel and equipment are clear from the area of operation and equipment movement. Check clearances in all directions, including overhead.
- ✓ Be properly seated in the operator's seat.
- ✓ Do not attempt to operate until you have read and fully understand this manual and the OEM manual for the carrier.

# OPERATIONAL SAFETY

## Check the Equipment

Before use, check the equipment to ensure it is in good operating condition.

Check the following:

- ✓ Grease fittings. Pump grease at all fitting locations, see page 27.
- ✓ Hydraulic fluid level. Add hydraulic fluid as required.
- ✓ Hydraulic hoses and hose connections for wear or leaks. Repair or replace any damaged hoses or connections.
- ✓ All control levers for proper operation.
- ✓ Rotation bearing. Visually check for loose or damaged bolts. If repair is required, refer to qualified personnel.
- ✓ Grease rotation bearing and pinion gear.
- ✓ Check for loose or missing pin retaining bolts.
- ✓ Check cylinders for dents (barrel) or dings (rod).



**GOOD  
CONDITION**



**WARNING**

Serious injury or death could result if warnings or instructions regarding carrier stability and the work area are not followed properly.

## Stability

Your Genesis attachment is sized for carrier stability. However, improper operation, faulty maintenance or unauthorized modifications may cause instability.

- ✓ Know the working ranges and capacities of the carrier to avoid tipping.
- ✓ Use the recommended carrier counter weight.

The following conditions affect stability:

- Ground conditions
- Grade
- Weight of attachment
- Contents of attachment
- Operator judgement



For greater stability, knuckle the attachment to bring the load closer to the center of rotation (center of gravity) while lifting. Use extra caution during reaching to avoid tipping.

# OPERATIONAL SAFETY

## **Know the Work Area**

Check clearances in the work area. Keep all bystanders at a safe distance. Do not work under obstacles. Always check your location for overhead and buried power lines or other utilities before operation.

Check ground conditions. Avoid unstable or slippery areas. Position the carrier on firm level ground. If level ground is not possible, position the carrier to use the attachment to the front or back of the carrier. Avoid working over the side of the carrier.

To reduce the risk of tipping and slipping, never park on a grade exceeding 10% (one-foot rise over the span of a ten-foot run).

## **Starting Procedure**

Before operating, walk completely around the equipment to make certain no one is under it, on it or close to it. Keep all bystanders at least 75 feet away from the area of operation and equipment movement. Let all other workers and bystanders know you are preparing to start. DO NOT operate until everyone is clear.

Always be properly seated in the operator's seat before operating any carrier controls.

### **To start:**

- ✓ Make sure all controls are in the center (neutral) position.
- ✓ Be properly seated.
- ✓ Slowly operate all functions to check for proper operation and to bleed air from the hydraulic system.

### **To shut down:**

- ✓ Return your Genesis attachment to a rest position on the ground.
- ✓ Shut off the carrier engine.
- ✓ Work controls in all directions to relieve hydraulic pressure, per excavator manufacturer's instructions.



## **WARNING**

Serious injury or death could result if warnings or instructions regarding safe operation are not followed properly.

## **Place the Load Safely**

Do not move the attachment, or anything held in the jaws, over people, equipment or buildings. Do not throw or drop the contents. Operate the controls smoothly and gradually.

# OPERATIONAL SAFETY

## Safely Operate Equipment

Do not operate equipment until you are trained by a qualified operator in its use and capabilities.

See your carrier's manual for these instructions.

- ✓ Operate only from the operator's seat. Check the seat belt daily and replace if frayed or damaged.
- ✓ Do not operate this or any other equipment under the influence of drugs or alcohol. If you are taking prescription medication or over-the-counter drugs ask your medical provider whether you can safely operate equipment.
- ✓ Never leave equipment unattended with the engine running or with the attachment in a raised position. Apply the brakes before exiting the equipment.
- ✓ Do not exceed the lifting capacity of your carrier.
- ✓ Avoid conditions that can lead to tipping. The carrier can tip when operated on hills, ridges, banks and slopes. Avoid operating across a slope which could cause the carrier to overturn.
- ✓ Reduce speed when driving over rough terrain, on a slope, or when turning to avoid overturning the carrier.
- ✓ Never use the attachment as a work platform or personnel carrier.
- ✓ Keep all step plates, grab bars, pedals and controls free of dirt, grease, debris and oil.
- ✓ Never allow anyone to be around the equipment when it is operating.
- ✓ Do not operate poorly maintained or otherwise faulty equipment. Inform the proper authority and DO NOT resume operation until the problem has been fixed.
- ✓ Do not alter or remove any safety features.
- ✓ Know your work site safety rules as well as traffic rules and flow. When in doubt on any safety issue, contact your supervisor or safety coordinator for an explanation.
- ✓ A heavy load can cause equipment instability. Use extreme care during travel. Slow down on turns and watch out for bumps. The equipment may need additional counter-weights to counterbalance the weight of the attachment.



# OPERATIONAL SAFETY

## Transporting the Attachment

- ✓ Travel only with the attachment in a safe transport position to prevent uncontrolled movement. Drive slowly over rough ground and on slopes.
- ✓ When driving on public roads use safety lights, reflectors, Slow Moving Vehicle signs, etc., to prevent accidents. Check local government regulations that may affect you.
- ✓ Do not drive close to ditches, excavations, etc., as cave-in could result.
- ✓ Do not smoke when refueling the prime mover. Allow room in the fuel tank for expansion. Wipe up any spilled fuel. Secure cap tightly when done.

## Equipment Condition

Never operate poorly maintained equipment. When maintenance is required, repair or replace parts immediately.



### WARNING

Serious injury or death could result if warnings or instructions regarding working overhead are not followed properly.

## Working Overhead

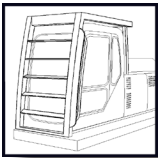

Avoid handling material overhead whenever possible. Safety glass and wire mesh cab guarding must be installed to protect the operator from flying debris that may be created during handling. Falling Object Protection Structures, or FOPS, are necessary for any application where material is to be handled overhead.



### DANGER

Serious injury or death will result if warnings or instructions regarding power lines are not followed properly.

## Power Lines

Do not operate the machine near energized power lines. All local, state/provincial and federal regulations must be met before approaching power lines, overhead or underground cables, or power sources of any kind with any part of the carrier or attachment. Always contact the appropriate utility when operating near power lines. The lines should be moved, insulated, disconnected or de-energized and grounded before operating in the area.



Current in high voltage lines may arc some distance from the wire to a nearby ground. Keep all parts of the machine at least 50 feet (16m) away from power lines.

## OPERATIONAL SAFETY



### WARNING

Serious injury or death could result if warnings or instructions regarding hydraulic fluid pressure are not followed properly.

#### Use Care with Hydraulic Fluid Pressure

Hydraulic fluid under pressure can penetrate the skin and cause serious injury or death. Hydraulic leaks under pressure may not be visible.

- ✓ Keep unprotected body parts, such as face, eyes and arms as far away as possible from a suspected leak. Flesh injected with hydraulic fluid may develop gangrene or other permanent injuries.
- ✓ If injured by injected fluid see a doctor immediately.
- ✓ Wear safety glasses and protective clothing and use a piece of cardboard or wood when searching for hydraulic leaks.

**Do Not Use Your Hands!**  
**See illustration below.**

- ✓ Hydraulic oil becomes hot during operation. Do not let hydraulic oil or components contact skin, as it could cause severe burns. Allow hydraulic components to cool before working on them. Use appropriate protective clothing and safety equipment. If burned, seek immediate medical attention.

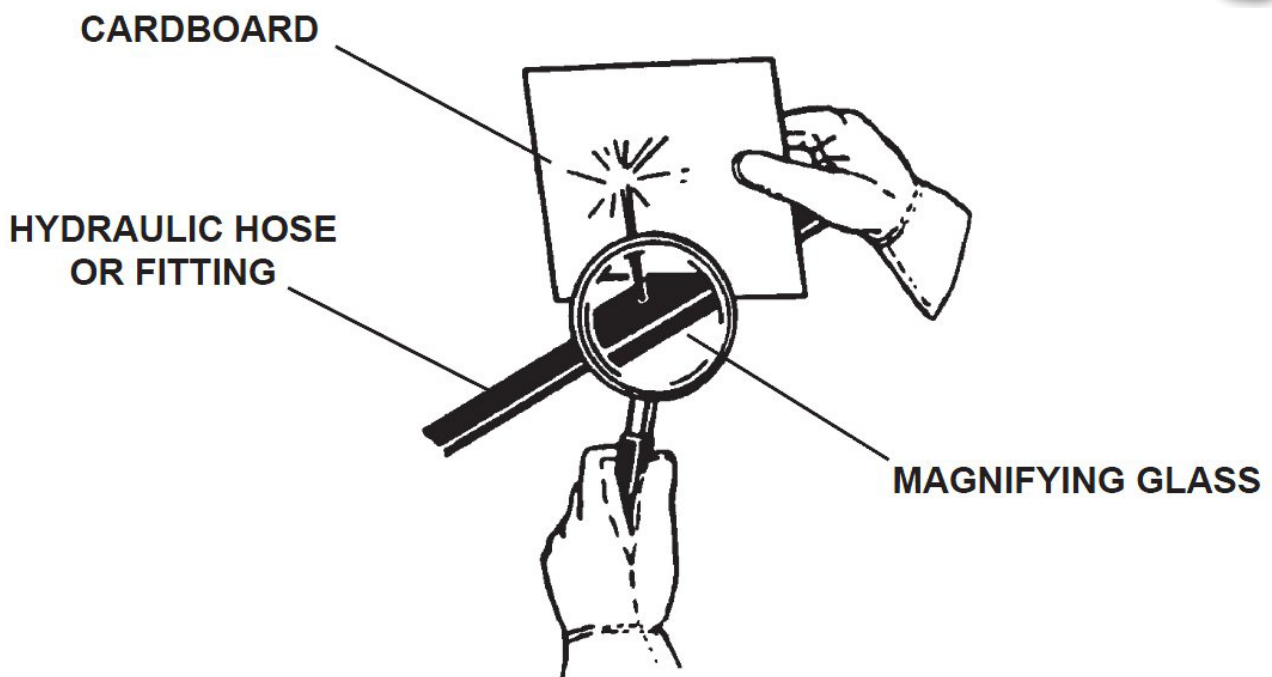

## OPERATIONAL SAFETY

### Prioritized Oil Flow

Equipment operators must ensure there is prioritized oil flow to the main valves in overhead operations or high reach conditions.

### Emergency Situations

Always be prepared for emergencies. Make sure a fire extinguisher is available. Be familiar with its operation. Make sure to inspect and service the fire extinguisher regularly. Make sure a first aid kit is readily available.



### Unsafe Conditions

Do not operate if an unsafe condition exists. Stop operation immediately, shut down the machine and report the unsafe condition to the proper authority. Equipment operation and maintenance practices directly affect your safety and the safety of those around you. Always use common sense while operating and be alert to unsafe conditions.

### Crystalline Silica Dust

It is recommended to use dust suppression, dust collection and if necessary, personal protective equipment during the operation of any attachment that may cause high levels of dust.



**DANGER**

Exposure to respirable crystalline silica dust along with other hazardous dusts may cause serious or fatal respiratory disease.

**IMPORTANT:** Concrete and masonry products contain silica sand. Quartz, which is a form of silica and the most common mineral in the Earth's crust, is associated with many types of rock.

Some activities that may have silica dust present in the air include demolition, sweeping, loading, sawing, hammering, drilling or planing of rock, concrete or masonry.

It is recommended to use dust suppression (such as water) or dust collection (such as a vacuum) along with personal protective equipment if necessary during the operation of any attachment that may cause high levels of silica dust.



### Prop. 65 Warning for California Residents



**WARNING**

This product may contain chemicals known to the State of California to cause cancer, birth defects, or other reproductive harm. For more information visit: [P65Warnings.ca.gov](http://P65Warnings.ca.gov)

## OPERATIONAL SAFETY



### **WARNING**

Using your Genesis attachment in unauthorized applications may create an unsafe situation and will void the warranty.

### **Process Material Safely**

- Do not process hardened steel material such as tool steel, railroad rail, axles, springs, machined parts or high-strength material. Hardened/high-strength material breaks, rather than shears, which may cause flying debris. It will also cause damaging decompression spikes to your Genesis attachment and base carrier hydraulic systems.
- Do not operate any functions of the carrier while cutting or crushing with your attachment, including boom and drive functions.
- Do not pull down structures with your Genesis attachment. Doing so may cause falling debris or material to break free and exceed the capacities of the carrier, causing a tipping hazard and rotation component failures.
- Do not use rotation to pry or break material. Doing so exerts high back-driving forces and spikes to the rotation circuit components that cannot be cushioned hydraulically. It may also cause motor and gearbox failures. The rotator should only be used for positioning an attachment.
- Do not process pressurized containers unless the main valve has been removed and you are absolutely certain the container is empty.
- Do not process spring loaded brake chambers and automotive struts as the release of compressed springs is extremely dangerous. Nothing made of spring material or containing springs should be processed.

### **Lift the Load Safely**

- The hydraulic system has been preset and tested by your dealer. Do not alter hydraulic settings without consulting an authorized Genesis dealer or the Genesis Service Department. Doing so will void the warranty and may cause structural damage, accidents or tipping.
- Make sure the load is held securely in the jaws. Do not move a loaded attachment if load is loose or dangling. Make sure the load is pinched between the jaws – never cradle a load.
- For greater stability, knuckle the attachment to bring the load closer to the center of rotation (center of gravity) while lifting. Use extra caution during reaching to avoid tipping.

### **Place the Load Safely**

- Do not move the attachment, or anything held in the jaws, over people, equipment or buildings. Place the load gently. Do not throw or drop the contents.
- Operate the controls smoothly and gradually. Jerky controls are hazardous and may cause damage to the carrier.
- Avoid fire hazards. Keep the area clean. Remove all flammable materials from the area during any welding or heating process. Have a fire extinguisher nearby and know how to use it.
- Never substitute pins or bolts. Use factory supplied pins. Replace all bolts with the same size and grade. Failure to do so may cause serious injury or death.
- Use your Genesis attachment only as directed in this manual. Do not use the attachment to lift and move other objects. Doing so may cause instability and tipping.

## ATTACHMENT MARKINGS

Decals are necessary for safe operation and maintenance. To reorder, contact your Genesis dealer or call 715-395-5252.

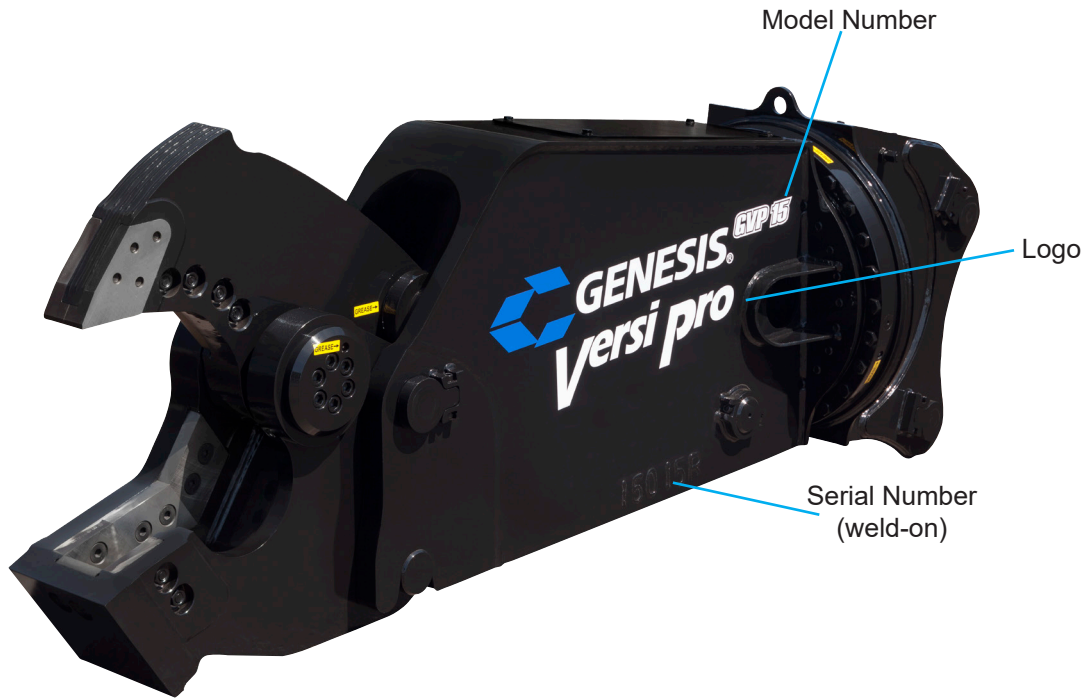

## ATTACHMENT INSTALLATION

**Preparation of the excavator prior to attachment delivery will make installation safer and easier. Contact Genesis or your Genesis dealer for assistance.**

### **Dual-Pump Flow**

An excavator typically has two hydraulic pumps that supply oil to its main control valve, which is usually separated into two halves. Combining the flow from both halves of the control valve is called summing, thus achieving dual-pump flow to operate one circuit.

Summing is the preferred method of achieving maximum speed to an attachment. However, interchanging the stick and bucket circuits may also substantially increase speed.

A bucket circuit is usually single-pump flow while a stick circuit is dual-pump flow. At times, adding an auxiliary circuit spool to the stick circuit helps reduce back pressure in the system and speed up jaw open and close.

In certain cases, the bucket and auxiliary circuits can be summated to achieve dual-pump flow, depending on whether the bucket and auxiliary are on separate sides of the main valve and whether the auxiliary circuit can be proportionally controlled by teeing into the bucket pilot control circuit.

The auxiliary circuit must also be capable of proportionally controlling pump initiation on the auxiliary side of the circuit. On many excavators, the auxiliary circuit is controlled by the flow percentage set in the operating system. Because attachments take all the flow the pumps can give them, when this percentage is reached, the pump will instantly turn on or off instead of gradually increasing or decreasing, which can cause sharp, damaging spikes in the hydraulic circuit.

If excavator circuits are electronically controlled, it may be necessary to reduce the spool shift and pump initiation in the excavator software to take spiking out of the circuit when changing attachment cylinder direction from full extend or full retract.

On excavators with full hydraulic spool piloting, install a flow control into the pilot lines between the joystick and spools. The flow control can then be adjusted to slow the pilot oil flow to the spool, which in turn slows how the spool shifts and the pumps stroke up.

## ATTACHMENT INSTALLATION



### WARNING

Be sure hydraulic pressure is relieved before disconnecting hydraulic fittings. Remove necessary fittings SLOWLY.

The attachment is usually shipped in an upright position. Extreme care must be used when inverting the attachment for installation.

Follow the excavator OEM's removal and safety instructions to remove the bucket or other stick attachments.

Position the Versi Pro upside down on flat, solid ground. Blocking may be required to raise the mounting bracket into proper position.

Track the excavator to the GVP with the jaws facing the operator. Lift the excavator stick over the Versi Pro, carefully positioning the stick tip connection with the GVP mounting main pivot bore. Pin the excavator stick to the GVP.

Slowly raise the boom to lift the GVP, allowing the cylinder pivot connection to come within range of the excavator cylinder stroke.

Extend the excavator cylinder until the power link bore lines up with the cylinder pivot connection. Pin the excavator cylinder to the GVP.

Crowd and extend the Versi Pro, checking closely to make sure there is no interference between the bracket and hard lines. Also check for interference between the cylinder and boom/stick.

Install excavator hydraulic hoses, supply and return, from the stick tip to the GVP manifold blocks.

The stick and bucket circuits are oriented as to rod and bore sides of their respective cylinders. Be sure to connect rod-to-rod and bore-to-bore when connecting a circuit to the attachment. When these are reversed, extra pressure is needed to open the jaw, which pulls down the engine, de-strokes the pumps, increases jaw cycle time, creates high oil temperature and burns more fuel.

The Versi Pro must be vertical before putting oil into it or an air lock in the regen valve may prevent the jaw from opening.

**Note: Genesis' standard pin material is Induction Hardened Chrome (IHC), which is to be used for all direct pin 2<sup>nd</sup> and 3<sup>rd</sup> member mounting. To avoid risk of pin failure when using a pin grabbing coupler, the standard IHC pins must be replaced with a heat-treated pin material from Genesis.**

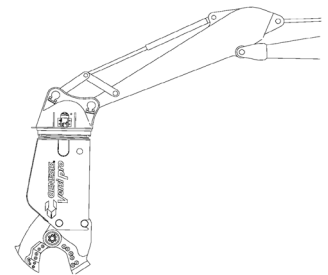
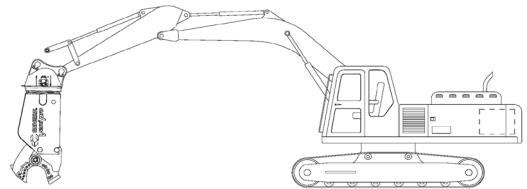
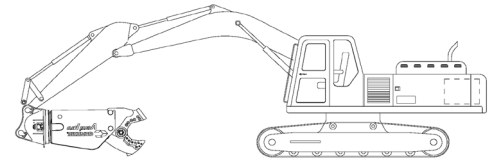

### WARNING

Removing any connecting pin may be hazardous. To remove a connecting pin, position the attachment on the ground and properly support. Particles may fly when a pin is struck. Use a drift pin or mallet when striking pins. Keep all personnel at a safe distance.

# ROTATOR INSTALLATION

## Rotation Circuit - Gear Pump Type

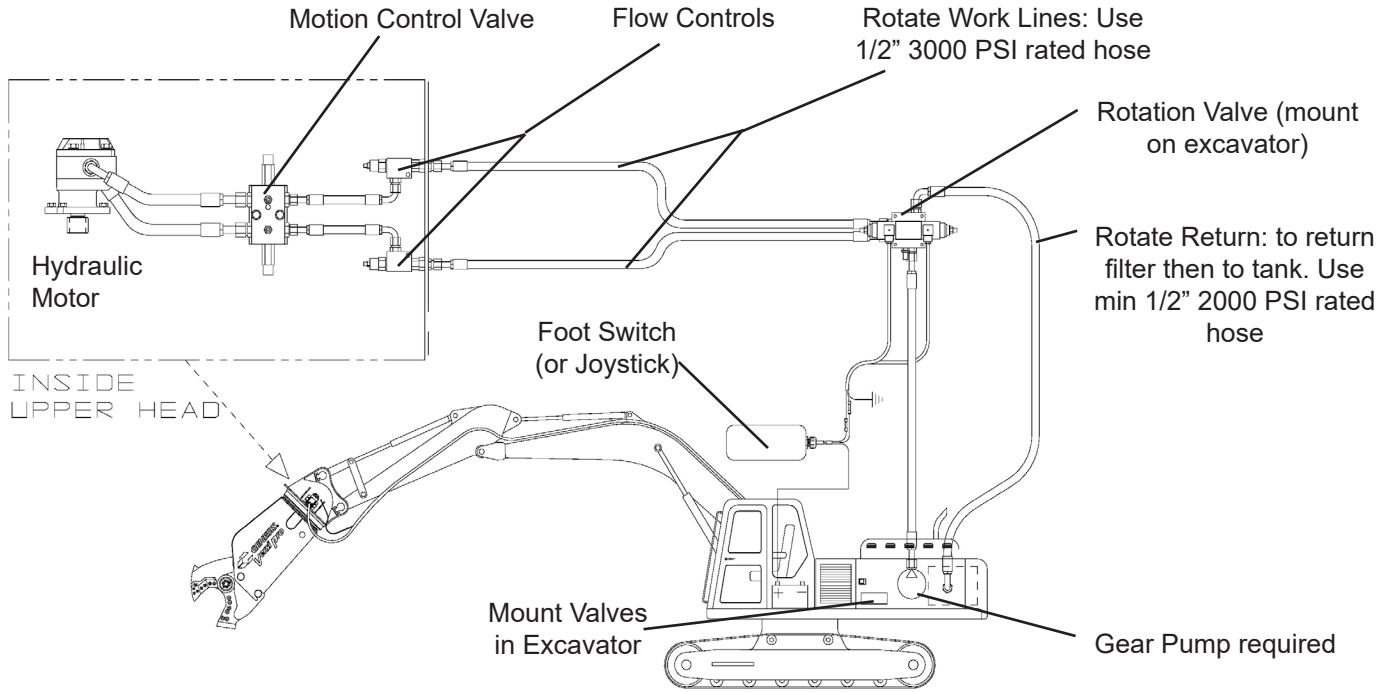

# ROTATOR INSTALLATION

## Rotation Circuit - Auxiliary Valve on Machine

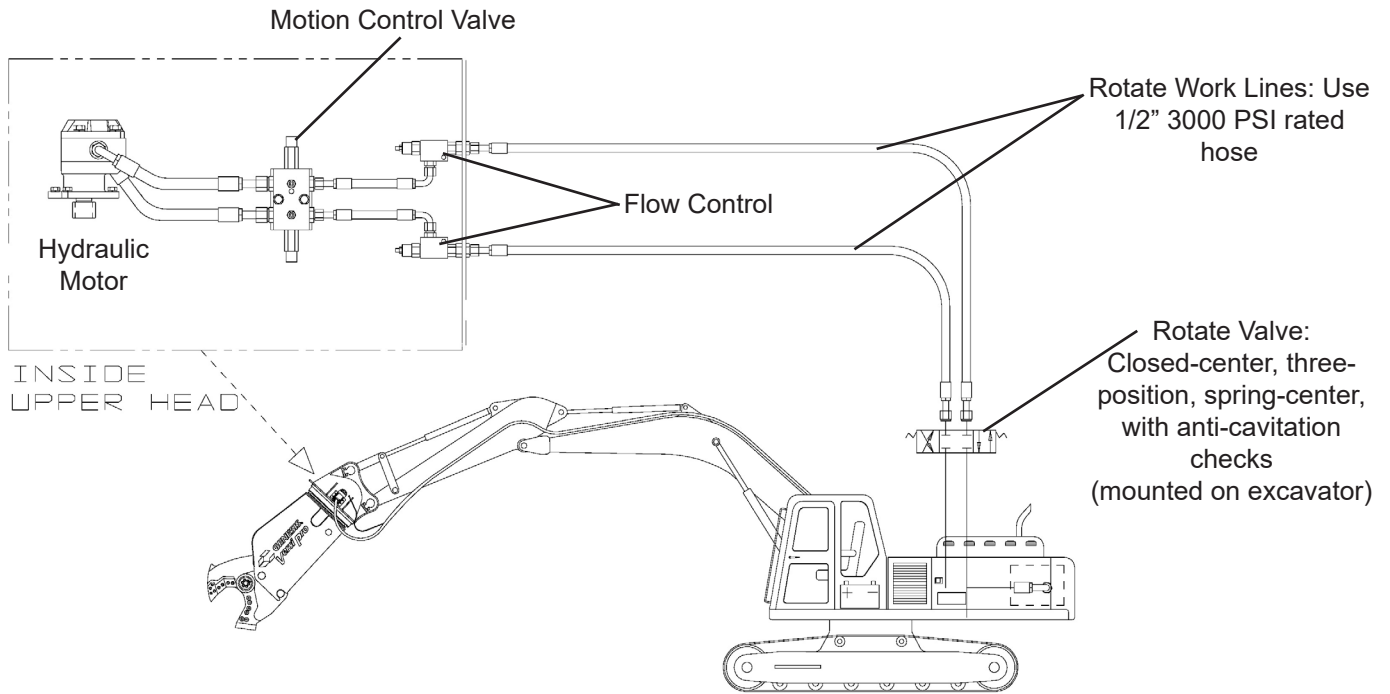

## HYDRAULIC START-UP

The GVP 15 is designed to operate under full excavator pressure or up to 5500 PSI. Due to these high pressures, it is important to bleed air from the attachment cylinder after installation. Failure to follow these procedures could result in cylinder seal damage and/or excavator hydraulic system damage.

### Start-up Procedure

- ✓ Check the excavator hydraulic tank for proper fluid level.
- ✓ Excavator oil should be warmed up before hooking up attachment lines in cold weather. If the oil is cold, air from the cylinder will be pushed into the oil tank, causing the oil to foam. This problem takes hours to correct and may cause pump cavitation.
- ✓ Follow the OEM procedures for starting and warming the excavator hydraulic system. Do not operate the attachment circuit during the warm-up period.
- ✓ After the excavator has reached normal operating temperature, set the engine to idle speed.
- ✓ The attachment must be vertical. Do not allow the tank to run low - have someone watch the oil gauge.
- ✓ Slowly fill the bore end of the attachment cylinder to partially close the jaws.

## NOTICE

Do not fully extend or retract the attachment cylinder with the first cycles.

Slowly fill the rod end of the attachment cylinder to open the jaws. Use partial strokes extending and retracting, slowly working to full strokes.

Stop and check the excavator hydraulic fluid level again to be sure there is still sufficient fluid. Service as required. The hydraulic fluid level should be checked with the attachment jaws open (cylinder retracted).

Cycle the attachment jaws five or six strokes before increasing to full operating pressure.

### Rotation Valve Input

For cooler and more efficient hydraulic system operation, set the input pressure and flow as indicated in the chart below. The attachment rotation speed should be 3 - 4 RPM. Exceeding 4 RPM will result in rotation component damage.

The maximum case drain pressure measured at the shear while rotating and cycling the jaws must never exceed 40 PSI. Pressure increases during cold-weather operation.

Jaw Circuit	Hydraulic Pressure	Rotate Circuit	Hydraulic Pressure
Flow	25 - 45 gpm (95 - 170 lpm)	Flow	3-5 gpm (11 - 19 lpm)
Pressure	4,000 - 5,500 psi (276 - 380 bar)	Pressure	1,500-1,700 psi (103 - 117 bar)

## GENERAL OPERATION INSTRUCTIONS

Follow all rules and procedures outlined in the Operational Safety section of this manual.

Use the attachment only as intended, in approved applications, as set forth in this manual.

Do not allow attachment, exposed cylinder rod or hoses to come into contact with any obstacles, buildings or the excavator.

The attachment is not intended to crush or break objects or structures by swinging or dropping the attachment.

### **Start-up**

During initial operation and any time jaw maintenance has been performed, process thin and lighter material first to work-harden wear areas, developing a harder, more durable edge. This is also the most effective time to process materials such as sheet metal or wire. The new or repaired edges will cut more efficiently and be less likely to jam material between the blades.

### **NOTICE**

When operating in temperatures below freezing, it is also important to process light materials first. This allows the attachment's structural material to warm up, preventing thermal cracking.

### **Efficient and Productive Operation**

Operators should become accustomed to performing work in the most proficient manner possible.

When cutting, build up and cut out of small piles, keeping the surfaces of the attachment chin plate and upper jaw out of the dirt as much as possible. Dirt is much more abrasive than steel and needlessly increases build-up and hard-surfacing time and intervals.

It also helps to give yourself enough room to keep out of the way of other personnel and machines. Material should be picked from a pile and swung to the side and cut in a new area. This prevents redundant cutting of the same pieces and allows for the newly prepared material to be loaded out with another material handling machine.

Material processing areas should be as close as safely possible to the location for loading materials for transportation. Less time spent processing, loading and transporting materials greatly affects operational costs and productivity and dramatically reduces man hours, fuel costs and wear on equipment.

Operators should develop the habit of assessing materials to be processed and visualizing a starting and finishing point to use the fewest cuts possible. Excessive moving, positioning and handling cost time and money. Bringing the jaws to full open, when only partial jaw open is needed for a cut, wastes time and fuel, slows other excavator functions as well as causes needless wear to hydraulic components, hoses and o-rings. More efficient processing will extend the life of the attachment.

## COMMON OPERATIONAL CONCERNS

### **Cutting Larger Materials**

When cutting larger materials the attachment jaw stalls just before cutting.

Suspend the material on the prepared pile, open the jaw and position the material as close to the throat as possible. Without pushing down on the material with excavator force, rapidly close the jaw on the material. Using the speed of regeneration can improve performance when cutting larger materials.

### **Chatter While Cutting**

If the attachment starts to chatter while cutting, back out of the cut and reposition at a different spot.

Chattering is an indication that material is jamming between the piercing blades and guide blades or between the upper and lower cutting blades. This indicates that blade maintenance needs to be performed immediately. Worn blades and improper blade gaps are usually the cause.

Insufficient piercing blade gaps will also cause this, as the blades and parent material of the jaws are subject to thermal expansion from cutting friction. The tighter the blades run, the hotter they get and the more they expand. Piercing blades and guide blades are the most susceptible to this and will show blue streaking on their corresponding faces. In some cases, they will get so hot that surface cracks and spidering occur. As this happens, it will spread the lower jaw and increase gaps between the primary and secondary blades, causing thin material to jam between them.

Another key area to watch is the opening between the guide blades. Be aware of material that may get into this opening before the piercing blade moves into this space, as it will be wedged between the piercing blades and guide blades.

Most jamming conditions can be prevented if the operator pays attention to the sound and vibration that is associated with a jam. Remember that because of the rod-to-bore ratios of displacement on the attachment's hydraulic cylinder piston, the attachment has half the force on jaw open compared to jaw close. So if the attachment is jamming while closing, it won't have enough retract force to open.

## MAINTENANCE SAFETY

Only trained and authorized persons should perform maintenance on the attachment. To be qualified, you must understand the instructions in this manual, have training, and know the safety rules and regulations of the job site.

Do not alter the physical, mechanical or hydraulic operation of the attachment. Doing so may cause a dangerous situation for yourself and those around you and will void the warranty.

Do not attempt repairs you do not understand. If any questions arise regarding a safety or maintenance procedure, contact Genesis or your Genesis dealer.

Read this entire manual. All personnel must understand the maintenance and safety procedures.

Use factory authorized parts. The use of unauthorized parts may compromise safety, performance and durability of the attachment and may void the warranty.

Follow the daily checklist and maintenance schedules in this manual. Extreme conditions may dictate shorter maintenance intervals.

Do not exceed bolt torque specifications.

Do not weld on structural components without consulting Genesis. Doing so may cause structural failure and void the warranty.

Do not operate an attachment without the case-drain line properly installed if the attachment uses a rotation system that requires a case drain. Doing so will cause immediate failure of the rotate motor and gearbox.

Do not work on the attachment before ensuring it will not move. Completely lower the boom to the ground or a rest position and relieve hydraulic pressure.

Never operate poorly maintained equipment. When maintenance is required, repair or replace parts immediately.

Do not operate under unsafe conditions. If an unsafe condition arises during operation, immediately shut down the equipment and report the situation to the proper authority.

## MAINTENANCE SAFETY

Do not work on any hydraulic lines or components while they are pressurized. Escaping hydraulic fluid can penetrate the skin, causing serious injury or death. Relieve pressure before performing maintenance. Keep hands and body parts away from pin holes and nozzles, which eject fluids under high pressure. Use a piece of cardboard to search for leaks.



If fluid is injected into the skin, seek medical assistance immediately from a doctor familiar with this type of injury.

### NOTICE

See Use Care with Hydraulic Fluid Pressure, page 13.

Hydraulic oil becomes hot during operation. Do not let hydraulic oil or components contact skin, as it could cause severe burns. Allow hydraulic components to cool before working on them. Use protective clothing and safety equipment.



Remove paint before welding or heating. Hazardous fumes/dust can be generated when paint is heated by welding, soldering or using a torch. Do all work outside or in a well ventilated area and dispose of paint and solvent properly.

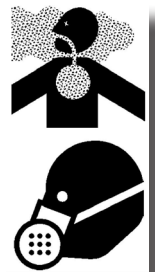

When sanding or grinding paint, avoid breathing the dust. Wear an approved respirator. If you use solvent or paint stripper, remove stripper with soap and water before welding. Remove solvent or paint stripper containers and other flammable materials from area. Allow fumes to disperse at least 15 minutes before welding or heating.

Avoid fire hazards. Keep the area clean. Remove all flammable materials from the area during any welding or heating process. Have a fire extinguisher nearby and know how to use it.



Never substitute pins or bolts. Use factory supplied pins. Replace all bolts with the same size and grade. Failure to do so may cause serious injury or death.

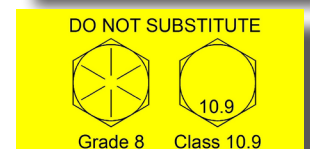

# MAINTENANCE SCHEDULE

Performing scheduled maintenance will promote safe, reliable operation of your attachment. Use the maintenance procedures described in this manual. If you are not able to safely and competently perform these procedures, have a Genesis dealer perform them.

Extreme operating conditions may require shortened maintenance intervals.

## **Eight-Hour Checklist**

### **Inspect:**

- Bolts - check for loose bolts, replace if damaged
- Fittings and hoses for damage or leaks
- Entire attachment for cracks (visual check)

### **Grease (every four hours, at mid-shift and end of the shift):**

- Rear cylinder pin
- Front cylinder pin
- Pivot group
- Remote grease fitting for rotation bearing
- Gear teeth inside bearing shroud

### **Jaws and Blades:**

- Check blade tolerance
- Check blade edge radius
- Check for loose or damaged bolts, retorquing loose bolts when cool
- Build-up and hard-surface as required
- Check grapple tine tips for excessive wear
- Check cracker teeth for wear; perform build-up and hard-surfacing as needed

## **Long-Term Maintenance**

- Grease cylinder pins at each jaw set change-over
- Check all bolts for loose washers, including slewing ring bolts, after the first 80 hours of operation
- Replace regeneration valve components every 2000 hours
- Reseal cylinder every 2000 hours

## LUBRICATION POINTS



Shut off excavator and disable hydraulics per OEM instructions before greasing.

For normal conditions above 32°F (0°C), use a lithium-based, premium grade 2 extreme-pressure grease. For temperatures below 32°F, use a grade 0 grease.

**Do not use grease containing Molybdenum (Moly).**

Genesis GLG-2® anti-wear, extreme-pressure lithium grease, PN 6302601, is recommended for all temperature conditions.

Grease all fittings every four hours of operation, at mid-shift and the end of the shift, when the attachment is warm. Grease until extrusion is visible.

After greasing the rotation bearing, rotate the attachment through two full rotations.

Grease locations:

1. Rear cylinder pin
2. Front cylinder pin
3. Pivot group
4. Remote grease fitting for rotation bearing
5. Gear teeth inside bearing shroud

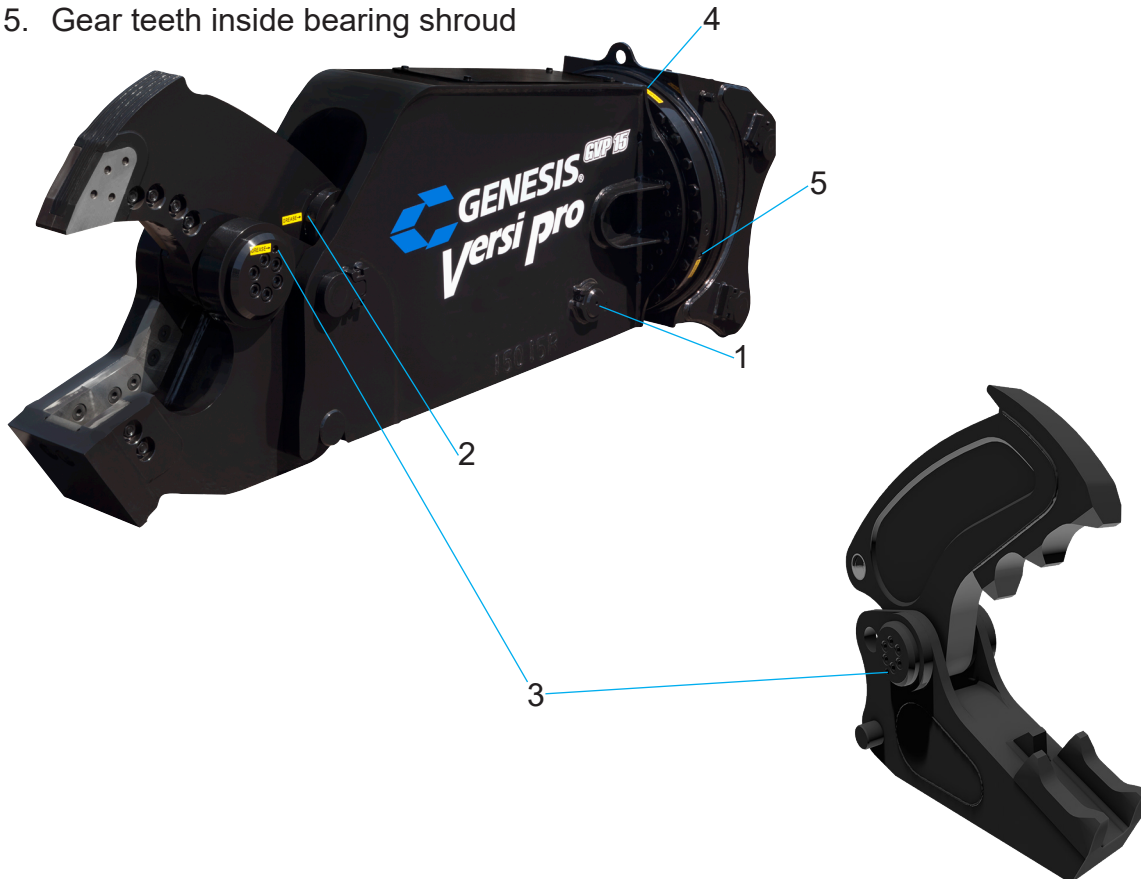

# JAW SET CHANGE-OVER

## Jaw Removal

It is safer, easier and quicker to change the jaw sets with two people; one person to remove the attaching pins and the other to operate the machine.

Position the attachment with the lower side of the stick toward the ground. Set the tool firmly onto flat, level ground.

Fully close the jaw. Remove the pin head retaining bolts from both the front cylinder pin and the jaw connection pin. (Fig. 1)

Remove the front cylinder pin. Slowly retract the cylinder rod (jaw open function). If the upper jaw moves, stop and pry the cylinder clevis away from the upper jaw.

Fig. 1

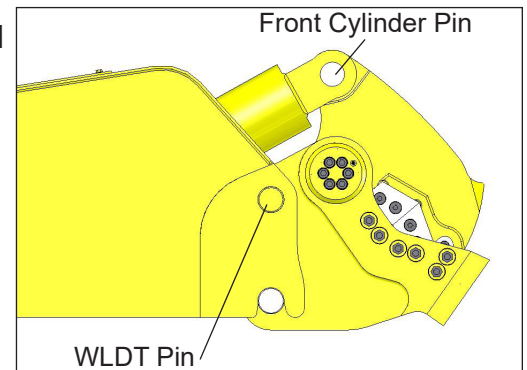

## **WARNING**

Close the jaws before rotating the attachment back to the vertical position. Failure to do so will allow the jaw to close which may cause serious injury or damage.

Remove the jaw connection pin.

With the pins removed and the attachment stick returned to a position with the lower side of the stick facing the ground, raise the stick up and tilt the jaw upward until the lower jaw attachment pins clear the stick body attachment hooks.

## Jaw Installation

The jaw set to be installed should be placed on firm level ground with the cylinder connection facing upward.

Tilt the shear stick back into a 30° position to hook onto the lower jaw attachment pins. Once they are connected, tilt the shear stick forward to align the jaw connection pin. (Fig. 2)

Install the jaw connection pin and its retaining bolt.

Extend the cylinder rod (jaw close function) until the cylinder connection aligns itself to the jaw connection. Install the front cylinder pin and its retaining bolt. You may need to pry the jaw open to properly align the jaw connection pin stick and jaw bores.

Slowly open and close the jaw to check for any interference.

Fig. 2

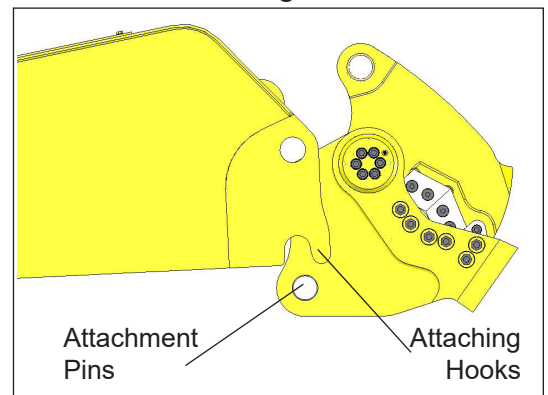

# SHEAR JAW SET MAINTENANCE

Perform the following daily maintenance checks to keep the attachment in good operating condition.

- Ensure proper pivot group adjustment
- Check piercing and cutting blades for excess wear and rotate or replace as needed
- Inspect jaws for wear

## Piercing Blades

Piercing blade maintenance is crucial for productivity and safe operation. An improper blade gap may cause material jamming and/or blade breakage.

Use the following procedure to check for wear.

1. Slowly close jaws until the piercing blades are flush with the top edge of the razor blade.
2. Check gap with a tape measure. Acceptable gap is 5/8".
3. Check the condition of the piercing blades with a straight edge or square.
4. Check the profile along the blades.
5. Badly worn blades must be replaced. However, slightly worn blades may be squared up with a grinder and a square. This may be repeated until a maximum of 1/2" of material is removed from the lower piercing edge.
6. Typical use requires blade replacement at approximately 200 hours; heavy piercing requires replacement at approximately 40 hours. These are general guidelines only. Replace blades based on wear not hours of operation.
7. Width of blades, top to bottom, may taper 0.060" (2 mm) total. Bottom edges may be worn to a maximum radius of 3/16".

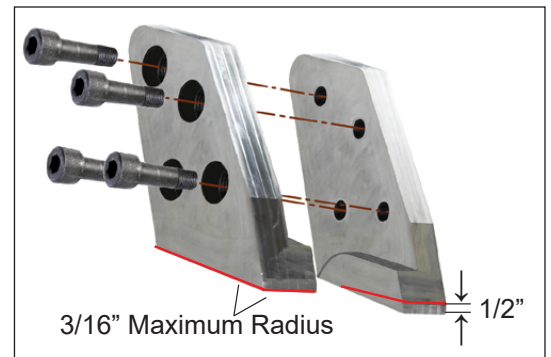
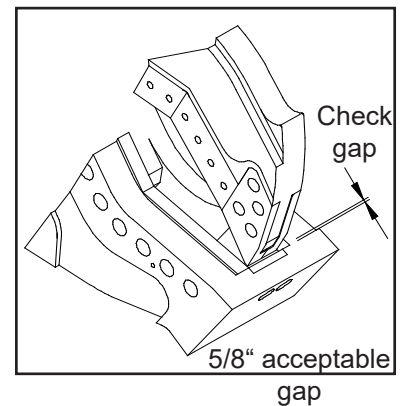

## PIERCING BLADES

Piercing blades must fit tightly in some areas while having clearance in others. Piercing blades are made from the same material as the cutting blades to withstand the friction caused by piercing hard materials.

Areas **Highlighted in Blue** require contact fit to the upper jaw and tang to prevent shattering.

Areas **Highlighted in Red** require an air gap, and blades may occasionally need to be ground down to provide clearance.

Piercing blade contact with the clearance areas (**red**) can cause abnormal stress in the blade. This may cause the piercing and/or guide blades to crack, break or shatter.

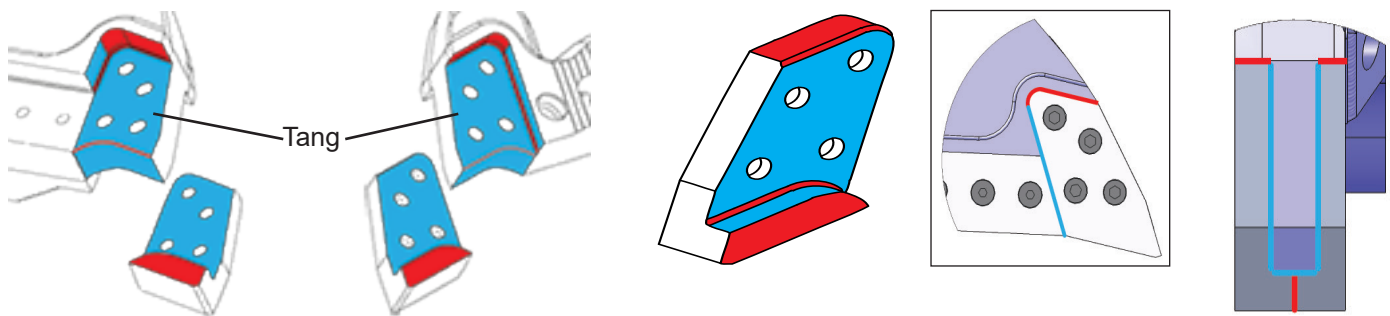

When necessary, build up the front lower edge of the tang and the front vertical surface of the upper (areas **highlighted in yellow**), following the procedures given in this manual. After welding, surfaces should be squared with a grinder and finished with a file and a machinist's straight edge.

It is critical that the piercing blade pocket and tang surfaces are straight and true, without dings, deformations, high or low spots, or areas that are worn away.

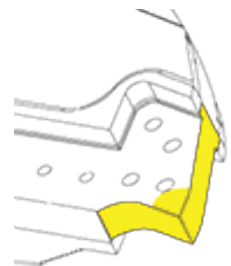

Piercing blade bolts must not make hard contact with the bolt holes in the upper tang. In rare cases it has been noted that improper alignment of piercing blade bolt holes and the bolt holes in the tang can cause the piercing blades to break through the bolt holes.

**When installing the piercing blades, the bolts must be freely installed by hand, not with an air impact wrench.**

The bolts may start freely, but when the bolt shank, which is larger in diameter than the threads, enters the hole in the tang, the interference can cause side loading to the piercing blades. This can cause the tips to break as they try to force the holes apart, or it may force the tips to seat improperly on the tang which can also cause tip failure. This is not a common issue, but one that should be noted as part of routine tip maintenance to prevent unnecessary costs and downtime. If this situation is encountered, contact the Genesis Parts or Service Departments for further instructions.

## PIERCING BLADES

### Replacement

1. Remove blades using an air-impact wrench or breaker bar and multiplier.
2. Remove dust and debris from blade seats; wipe down with a rag and solvent.
3. Lightly file deformities from blade seat edges. Do not sand or grind face of blade seats.
4. Install new, clean blades. Lubricate the threaded holes in the blade and on the bottom of the bolt head where it will contact the blade.
5. Snug lubricated blade bolts by hand to hold them in place; push blades up and into the upper and rear surfaces of the seats.
6. Torque bolts to 1/3 of the final torque value.
7. Check for firm contact against blade seats.
8. With a feeler gauge, confirm gap of 0.002" to 0.010" where blades meet at piercing surface. A very narrow gap may be confirmed by shining a flashlight from below the blades and seeing light pass through. If gap exceeds 0.010", call the Genesis Service Department. If no gap exists, remove blades, lightly grind facing surfaces and repeat steps 5-8.
9. Torque bolts to 2/3 final value, and then to final value, using a cross bolt pattern.

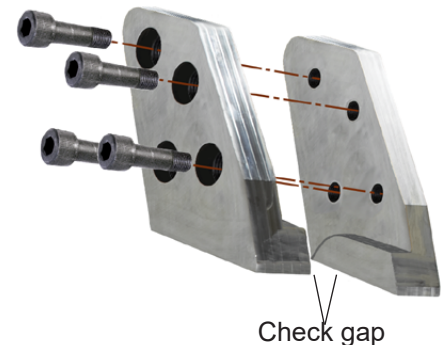

Correct clamping force is required to keep tips from moving on their seats. Over-tightening can cause bolt shanks to stretch, losing their clamping force. Loose bolts will cause the seating areas to erode.

### **NOTICE**

Piercing blade bolts must be lubricated and torqued as specified in the Bolt Torque Specifications section of this manual, see page 57.

## GUIDE BLADES

After performing piercing tip maintenance, check guide blade tolerances. When necessary, shim the guide blade to keep the gap within 0.005" - 0.010".

Rotate the guide blades when worn to a 1/8" (3 mm) radius. Replace the guide blade when more than 0.075" (2 mm) of shims are required to keep the blade gap within the tolerances.

Dual guide blades, one on either side of the lower jaw, allow for a wider tip-to-guide blade gap than is used between the main cutting blades. Friction and heat buildup cause piercing blades to expand, reducing clearance, possibly to the point of blade interference. Therefore, in some applications, it is beneficial to maintain a wider gap at the guide blades.

### **Shimming**

Slowly close the jaw so the upper piercing tip begins to bypass the guide blades. Stop the jaw and check the gap between the guide blades and piercing tip. Cycle the jaws slowly, stopping at several points along the piercing tip to check the gap each time.

Shim the guide blades as needed to keep the gap within the 0.005" - 0.010" tolerances.

To install shims, loosen blade bolts and slide shims between the guide blade and guide blade seat. Retorque bolts and recheck the gap.

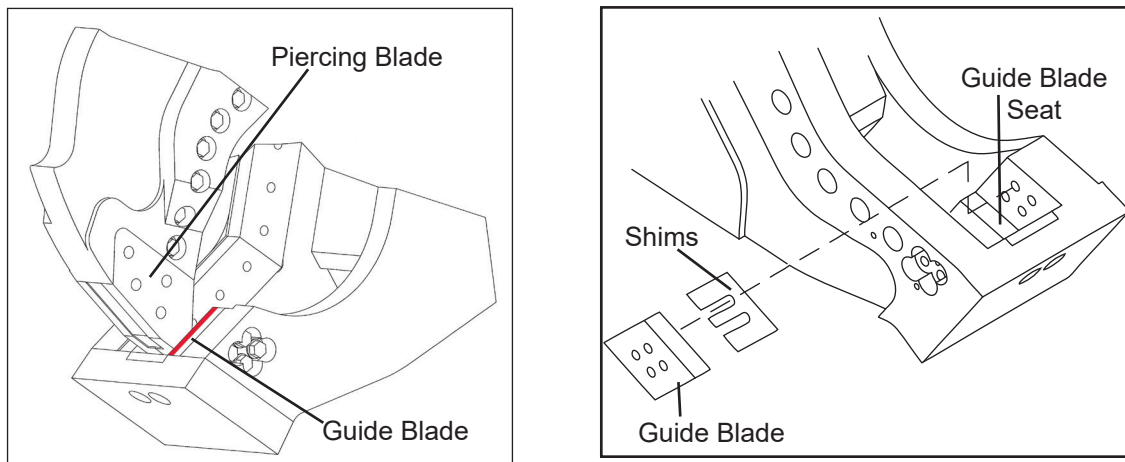

### **Rotation**

Remove the blade bolts, guide blade and shims. Rotate the blade end-for-end or side-to-side; reinstall and torque bolts. Check gap; shim if required.

If the guide blade faces are excessively worn, the blades cannot be rotated. Excessively worn blades will have uneven surfaces that, when placed upon guide blade seat surfaces, will not be supported and will break, resulting in blade seat damage.

### **Replacement**

Remove guide blade and shims. Install new guide blade with no shims. Check blade gap and shim as needed.

## PRIMARY AND SECONDARY BLADES

Proper maintenance of the primary and secondary blades, or cutting blades, is required for optimal performance. Blade rotation extends blade life and improves cutting performance. Dull blades make the carrier hydraulic system work harder and may cause structural damage to the attachment.

Rotate blades to use all four cutting edges. Always use Genesis-approved blades. Blades that do not meet Genesis specifications can cause major problems, and using them may void the warranty.

Before performing any blade maintenance, read, fully understand and follow these safety rules.

- Wear personal safety equipment including gloves, safety glasses, safety boots and proper clothing.
- Safe blade maintenance requires two people - one to steady the blade while the other loosens the bolts.
- Blades are heavy and may fall out of the blade seat if not adequately supported. Bystanders must stand clear.
- Never strike a blade with a hardened steel tool. The blade may fragment, creating sharp flying debris.

### **Removal**

Loosen the bolts on one blade at a time, enough to loosen the blades.

Carefully remove bolts and blades.

### **Blade Bolts**

Visually check for loose or broken bolts daily. Retorque loose bolts to the specifications listed in the Bolt Torque Specifications section of this manual, see page 57.

**Replace broken bolts immediately.**

# PRIMARY AND SECONDARY BLADES

## Rotation

Inspect blades every eight hours of operation. Retorque loose bolts and replace broken bolts. Rotate blades when the cutting edges are worn to a 1/8" (3 mm) radius.

Recommended rotation intervals are approximately 40-80 hours, depending on the material being processed. Thin materials may require shorter rotation intervals. Blades must be replaced when all four edges are worn to 1/8" (3 mm) radius.

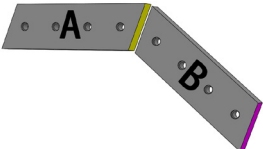
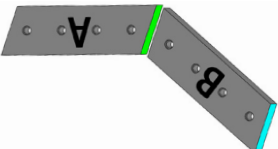
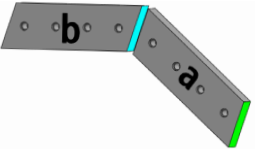
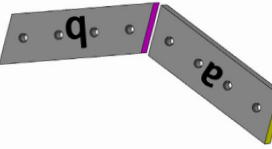
Original Blade Configuration	First Rotation Rotate both blades end-for-end	Second Rotation Rotate both blades front-to-back and exchange seat positions	Third Rotation Rotate both blades end-for-end
			

The following chart may be copied and used to track blade rotation.			
40 - 80 Hours	Date	Hour Meter	Performed By
<b>Installed</b>			
<b>Rotation 1</b>			
<b>Rotation 2</b>			
<b>Rotation 3</b>			

## CRACKER JAW SET MAINTENANCE

Replace teeth when points are worn down and can no longer process concrete efficiently. Weld new teeth in place using the following procedure.

If desired, points may also be rebuilt and hard-surfaced when 1/2" has worn away, as shown in the illustration. However, rebuilt points on the teeth will wear down faster than the original teeth.

### Tooth Replacement Procedure

Follow all welding safety precautions found in this manual.

Preheat the jaws surrounding the teeth to 350° F (177° C), being cautious to stay away from the pivot group. Maintain this temperature throughout the procedure. Do not exceed 400° F (204° C) interpass temperature.

Air arc to remove worn teeth, following the red lines shown in the illustration. Grind jaw surfaces smooth to accept new teeth.

Position and tack the new teeth in place as shown.

Weld with AWS E7018 electrode or equivalent. Begin with the sides, filling in the chamfered area with single passes, alternating sides and peening each pass. Weld the back and front of each piece following the same method.

When welding is complete, grind the welds flush on the sides of the upper jaw. Failure to grind these surfaces flat may prevent the teeth from bypassing the lower teeth.

Cycle the jaw slowly to check for interference.

Cover with heat blanket or insulation and allow to cool slowly.

DO NOT put unit into operation until cool, approximately eight hours.

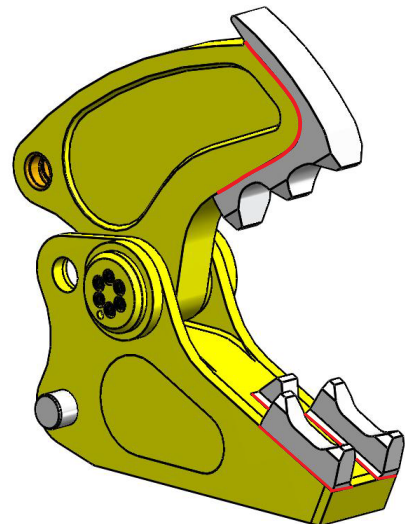
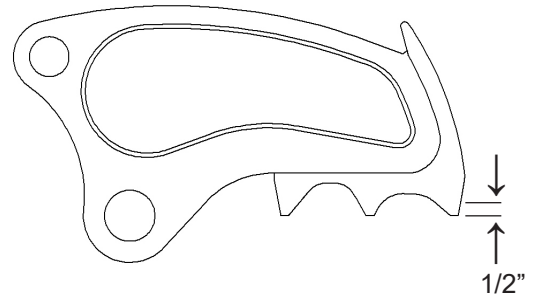

## GENERAL WELDING GUIDELINES

Build-up and hard-surfacing are welding procedures that protect the parent material of the jaws and keep the blades in good adjustment. Build-up is the welding procedure that restores the jaws to their original shape. Building up the jaws helps protect the blades and increases the life of the attachment. Hard-surfacing is the welding material added over the parent material (or build-up material) to create a wear-resistant surface.

Welding should not be performed until the jaws are work-hardened. Work-hardening can take up to 80 hours. However, jaws must not wear lower than the height of a new blade. If either jaw wears down lower than blade height, immediately stop operating the attachment and perform build-up and hard-surfacing as described in the following pages of this manual.

**When welding around blade seats or the piercing tip tang area, maintain the factory machined seat radius. If the rounded grooves are welded up, use a die grinder with a carbide tool to recut these areas to their original profile. Leaving a squared edge will eventually cause structural cracking. The radius provides a broader area to absorb structural stress.**

### Welding Ground Clamp

**Disconnect all battery ground cables or shut off master battery switch, if equipped. Failure to do so may cause excavator electrical problems, including permanent damage to onboard computer systems.**

**Connect ground clamp as close as possible to the area being welded without allowing current to pass through the pivot group, cylinder pin, cylinder, swivel, motor, gearbox or slewing ring.**

**If you are welding on the lower jaw, connect weld clamp to the lower. If you are welding on the upper jaw, connect to the upper but not to the cylinder clevis. If needed, weld a piece of steel to the area for the grounding clamp and cut the piece off when welding is completed.**

### Welding Rules

Before you begin:

- Remove adjacent blades, as preheating and welding may cause blade damage.
- Wearing an approved respirator, grind the area to clean it, removing all existing hard-surfacing.
- Preheat area to 350° F (177° C). Maintain this temperature throughout the procedure. Do not exceed 450° F (232° C) interpass temperature.

During welding:

- Always grind and weld with the grain of the material.
- Peen each weld pass to relieve stress and harden the welds.
- Do not undercut the ends of the welds.
- Do not start or stop welds directly above a bolt hole or in the apex of the jaw.

After welding maintenance is complete:

- Cover the area with a heat blanket and allow it to cool slowly, approximately eight hours.
- Do not put the attachment into operation until the welds have been allowed to cool.

## BUILD-UP

Procedure:

Follow the General Welding Guidelines and Rules.

Determine the area to build up, using a straight-edge or square. Jaws must not wear lower than the height of a new blade. Use a new blade to help determine build-up height for the jaw.

Build up the jaw to slightly higher than the original parent material profile with E7018. Apply single passes in each line with the grain of the steel, peening after each pass.

Protection strips, or raised areas under or around blade seats, must be built up and maintained during build-up procedure using E7018 or equivalent.

These areas should be maintained between blade height and 0.010" lower than blade height. These areas protect the bottom unused edges of the blades as well as reduce the chance for material to catch on the bottom of the blade during jaw open functions, which causes blades to move in their seats.

Denting, deformation or build-up higher than blades in these areas may cause upper jaw deflection, excessive blade gaps, wear to blade faces and undue stress to upper and lower jaws.

After build-up is complete, grind material to be flush with a new blade.

Note: Closely monitor areas above guide blade bolt countersinks and below front two upper blade bolt countersinks. These are high-wear areas. If allowed to wear too far, parent material starts to fold into the countersinks, and it becomes time-consuming to clean out this area when access is needed for blade rotation and replacement.

## HARD-SURFACING

Do not apply hard-surfacing directly to the parent material as this could cause toe cracking, and the hard-surfacing will break away.

Procedure:

Follow the General Welding Guidelines and Rules.

Apply a single pass stringer bead pattern, with the grain, using E7018 electrode. Peen each pass.

Do not apply a stringer directly on the edge. Start the first pass 1/4" from the edge.

Stagger the ends of the stringer welds so they do not end in a straight line.

Cap each stringer bead with one pass of GenWire or GenRod to hard-surface. Do not apply more than two layers of hard-surfacing. Peen each pass.

Grind the ends of all stringer welds with the grain to taper 1" to 1-1/2" (25 - 38 mm) to the parent material.

See the following page for hard-surfacing illustrations and instructions specific to each area of the jaws.

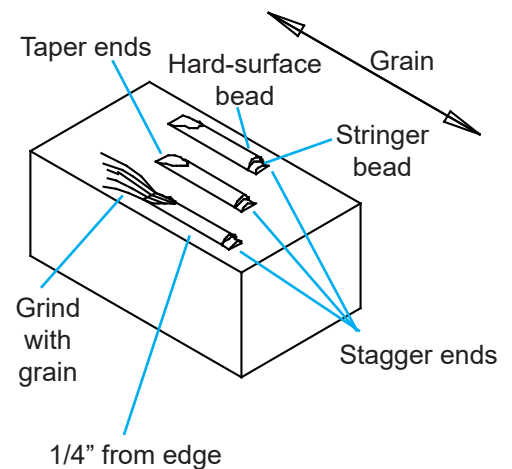

## HARD-SURFACING PATTERNS

Where parallel lines are shown, apply single passes approximately 1" apart. Where crosshatch is shown, apply stringer beads at 45° angles to form 1" squares.

Hard-surfacing patterns are indicated by red lines in the drawings.

**Do not crosshatch the curved areas of the jaws near the pivot.** Use only straight stringers on these areas.

### Shear Jaw Set

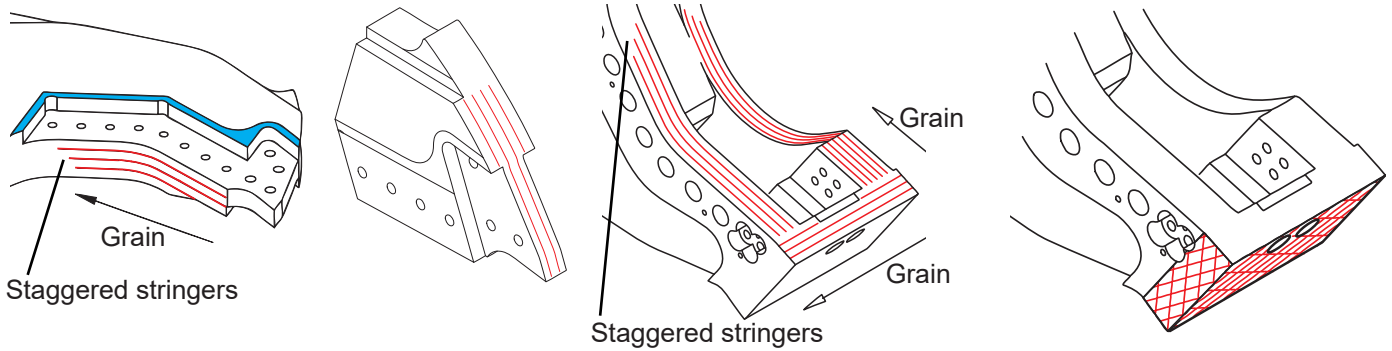

### Cracker Jaw Set

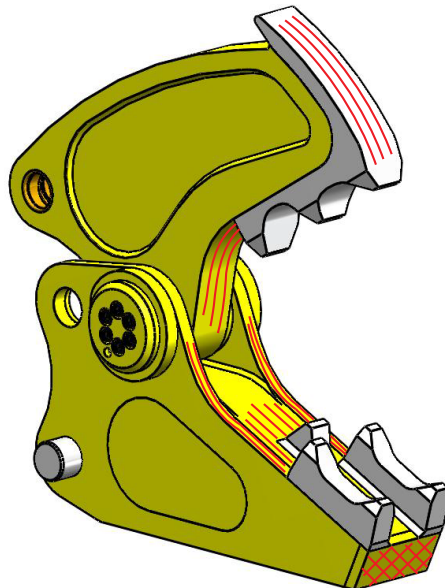

## GENFLOW REGENERATION VALVE

Regeneration valves feature GenFlow adjustment cartridges to control the timing of the shift between speed and power modes. When the cartridge is properly set, the processor closes rapidly until it begins to cut. The valve shifts, slowing jaw close and increasing power. You may hear a squeal or hiss as this happens. The valve shifts back into speed mode after the cut is complete.

Cartridges are factory-set, turned out approximately five turns. This setting is appropriate for most applications. However, the cartridges may be custom-set if necessary.

Regeneration valve adjustment is a two-person job. The ground crew must be in full view of the operator at all times and must stand clear of the processor jaws when cycling. Check the cycle time when the hydraulic fluid is warmed up, timing from full open to full closed and back to full open. To shift into power mode sooner, turn adjustment cartridge out (counter-clockwise). To shift into power mode later, turn in (clockwise).



Shut down and disable the hydraulics before adjusting the cartridge.

Loosen the lock nut with a 9/16" socket.

Turn cartridge 180° (half-turn, 145 PSI) with a 5/16" allen-head socket.

Tighten lock nut.

Check the cycle time.

Repeat until the preferred balance of speed and power is met. Final adjustment may require less than half-turn.

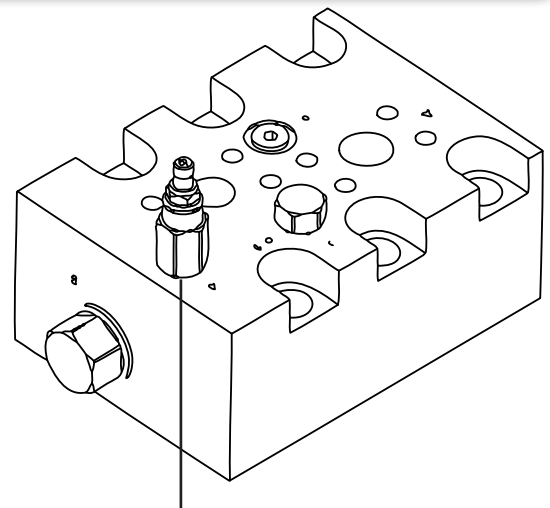

Adjustment Cartridge

# GENFLOW REGENERATION VALVE

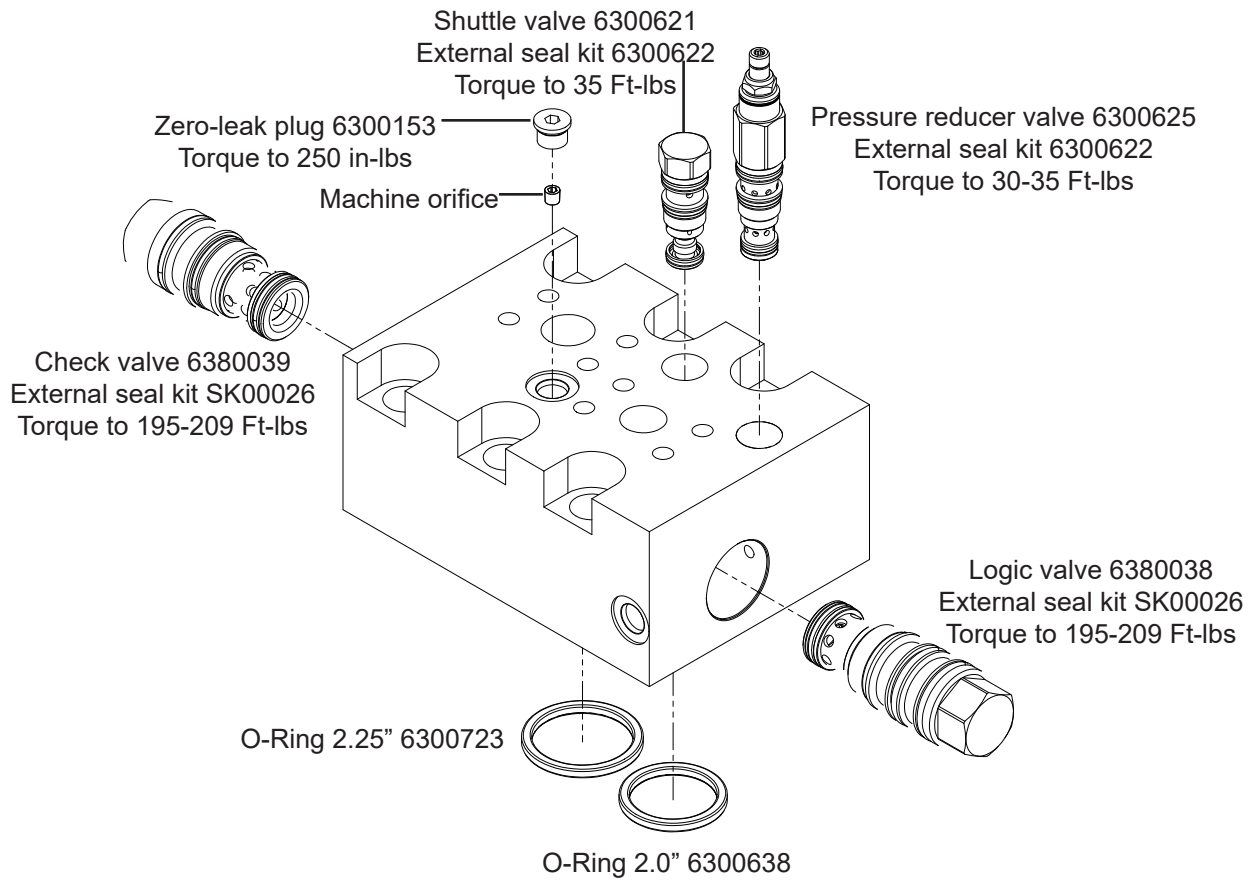

# GENFLOW REGENERATION VALVE - HOW IT WORKS

**Jaw Close in Regeneration:** Oil that would normally leave the rod end of the cylinder and return to the tank is diverted to the bore end of the cylinder, increasing flow by approximately 50 percent and speeding up jaw close. In this mode, oil pressure on both rod and bore sides of the cylinder piston are basically equal and, although this speeds up the cylinder extend speed, it results in pressurized fluid on the rod side. If left in this mode, cylinder power is greatly reduced.

**Jaw Close in Power Mode:** To provide full power, when the upper jaw hits the material, the pressure rises. Once pressure exceeds the adjustment cartridge settings, it then shifts the rod oil back to the excavator hydraulic tank instead of the bore end of the cylinder. Pressure in the rod also drops, allowing full force from the bore pressure to be applied to the upper jaw for full cutting.

**Jaw Open:** Oil goes to the rod end of the cylinder, and bore oil goes back to the tank.

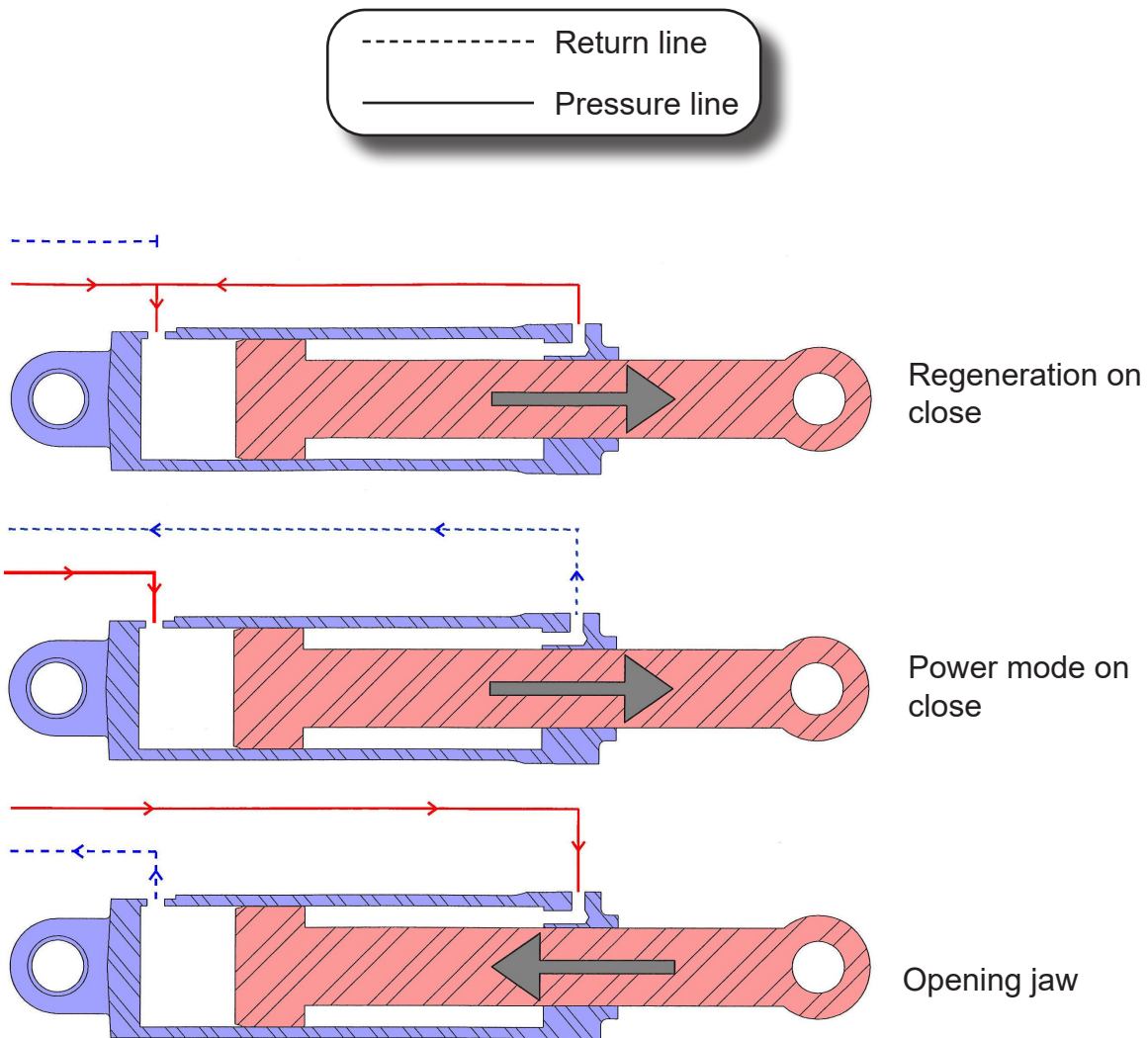

## SLEWING RING MAINTENANCE

Visually check slewing ring (rotation bearing) bolts every eight hours of operation. Do not reuse or re-torque these bolts. Loose or broken bolts, along with the bolts on either side, must be immediately replaced.

The bolts that secure the slewing ring are critical for safe attachment operation. Improper torque may cause the bolts to fail and the attachment to break free, which may result in serious personal injury and equipment damage. Improper torque will also cause uneven slewing ring wear.

Rotating components must be greased daily. Grease fittings are located on the outside of the slewing ring and on the inside of the rotating head assembly. Grease locations are marked with decals.

Grease each fitting and then rotate the attachment two full rotations.

For normal conditions above 32°F (0°C), use a lithium-based, premium grade 2 extreme-pressure grease. For temperatures below 32°F, use a grade 0 grease. **Do not use grease containing Molybdenum (Moly).**



Genesis GLG-2® anti-wear, extreme-pressure lithium grease, PN 6302601, is recommended for all temperature conditions.



Stand clear when the attachment is being rotated. Always stay in clear view of the operator.

# TROUBLE-SHOOTING GUIDE

## Jaw Set

Symptom	Possible Cause	Possible Solution
Lacks power	Circuit not getting full pressure from excavator	Check hydraulic pressure at port block
	GenFlow cartridge needs adjustment	Make adjustments following procedure listed in this manual
	Shear cylinder or swivel bypass	Check for bypass and replace seals if needed
	GenFlow valve has faulty cartridge or seal bypass	Contact Genesis Service Department Check valve seals, replace as needed
Poor cutting	Material size is beyond shear appetite range	Consult the factory
	Worn blades	See the jaw and blade maintenance sections of this manual
	Excess blade gap	
Poor piercing	Piercing tip or chin is worn	See the jaw and blade maintenance sections of this manual
Slow jaw cycle time	GenFlow cartridge needs adjustment	Make adjustments following procedure listed in this manual
Material jamming	Excess blade gap	See the jaw and blade maintenance sections of this manual
	Worn blades	
	Worn piercing tip, chin or guide block	
Slow jaw cycle in open direction	Excess back pressure on return side of cylinder	Check excavator main control valve or hydraulic line size
Jaw drifts closed or can be pushed closed	Excavator control valve	Check excavator main control valve
	Processor cylinder or swivel bypass	Check for bypass and replace seals if needed
	GenFlow valve seal bypass	Replace seal as necessary

# TROUBLE-SHOOTING GUIDE

## **Rotator**

<b>Symptom</b>	<b>Possible Cause</b>	<b>Possible Solution</b>
Does not rotate	Incorrect pressure settings	Set pressures
	Faulty control valve	Check excavator control valve
Does not rotate in one direction	Faulty directional control valve	Check if directional control valve shifts both ways while actuating foot switch in both directions
Rotator chatters	Pressure settings too high	Set pressures
	Faulty counterbalance valve	Replace or reseal
Rotates faster in one direction	One flow control cartridge set higher than the other	Set flow control
Rotates too fast or too slow	Flow control out of adjustment	Set flow control
Rotation speed changed from original setting	Jam nut loosened on rotation valve	Check jam nuts on rotation valve; set pressures
	Faulty cartridge (contamination)	Replace cartridge
	Faulty directional control valve	Check excavator control valve
	Pressure set too low	Set pressures

# WARRANTY

## **Claim Procedure**

Notify the Genesis Service Department of the potential warranty claim prior to making the repair. Digital pictures are very helpful for diagnosing problems and recommending repairs.

Contact the Genesis Service Department before making alterations, changes or repairs to any component that is going to be considered for warranty. Not doing so will void all Genesis warranty consideration.

The Genesis Service Department will issue an authorization number to track the repair costs, outgoing parts, and/or defective parts returning to the factory.

Replacement parts must be ordered using a purchase order number. Shipping is standard ground. Overnight shipping is available by request, and Genesis will not cover the shipping charge.

When the repair is complete, submit an invoice to the Genesis Service Department within 30 days. Include itemized internal labor reporting, parts lists and invoices for outside contractors. Reference the authorization number on all invoices.

When returning parts for warranty consideration, include a copy of any related Genesis paperwork along with any other necessary documentation to ensure proper processing and credit. The Genesis Service Department will provide the necessary forms.

Your account will be credited when the warranty claim is accepted.

## **Blade Warranty**

Standard warranty on blades will only be considered on the first edge, and wear on the edge must be 1/8" radius or less. Genesis does not warranty cutting blades that are cracked or broken from top to bottom (perpendicular to the long edge of the blade). Genesis also does not cover fasteners, the labor to replace wear components or collateral damage, such as blade seats, from broken blades, the piercing blade tang or adjustment plates.

**Please direct any questions to the Genesis Service Department: 715-395-5252**

# PARTS ORDER POLICY AND PROCEDURE

## **Parts Orders Should Include**

- Purchase order number
- Model and serial number of attachment
- Part number and quantity needed
- Shipping and billing address
- Method of shipment or required delivery date

## **Placing Orders**

Orders may be placed by phone or e-mail. To e-mail an order, use the form on the following page or your purchase order form. Contact information is located at the front of this manual.

## **Part Numbers**

Part numbers are listed in a separate Parts Manual or, if included, the Parts section of this manual. Contact the Genesis Parts Department with questions regarding part numbers, availability and pricing.

## **Shipping**

All orders will be shipped best way surface unless an alternate shipping method is requested. Shipping charges are not included in the purchase price of parts.

## **Invoices**

All invoices are due upon receipt. Any accounts with invoices open beyond 60 days are subject to review and may be placed on C.O.D. status without further notice.

## **Returns**

Many unused Genesis parts may be returned with proper documentation. Return shipping is the responsibility of the purchaser. Credit will be issued upon return, less a 25% restocking fee. Documentation is required for credit of returned parts. Contact the Genesis Service Department at 715-395-5252 for an RGA (Return Goods Authorization) number and form. An RGA must accompany every return. Items shipped without an RGA may be returned to sender.

## **Warranty Returns**

All parts returned to Genesis for warranty consideration must be returned with a completed RGA (Return Goods Authorization) provided by the Genesis Service Department. The form needs to be completed in its entirety, including any additional information requested by the Service Department. Return shipping is the responsibility of the sender and will be credited upon claim approval. A determination to accept or deny the claim will be made based upon the information available to Genesis. Warranty on purchased parts other than wear components is 6 months. Genesis does not cover labor costs to replace purchased parts replaced under warranty. There is no warranty period on wear parts or components.



## PARTS

The following pages contain illustrations and part lists for the Genesis Versi Pro 15. These photos and generalized drawings identify major components and may not be identical in fine detail to a particular attachment.

The part lists included here are intended to aid in operation and maintenance. Part numbers listed are those currently used. These may differ from the part numbers of the components originally installed in your attachment. To ensure use of the correct internal components, always indicate your attachment's model and serial numbers when ordering parts.

If further information is required, contact the Genesis Parts Department for a breakdown and parts list specific to your attachment model and serial number.

# PARTS

## Second-Member Mount Upper Head

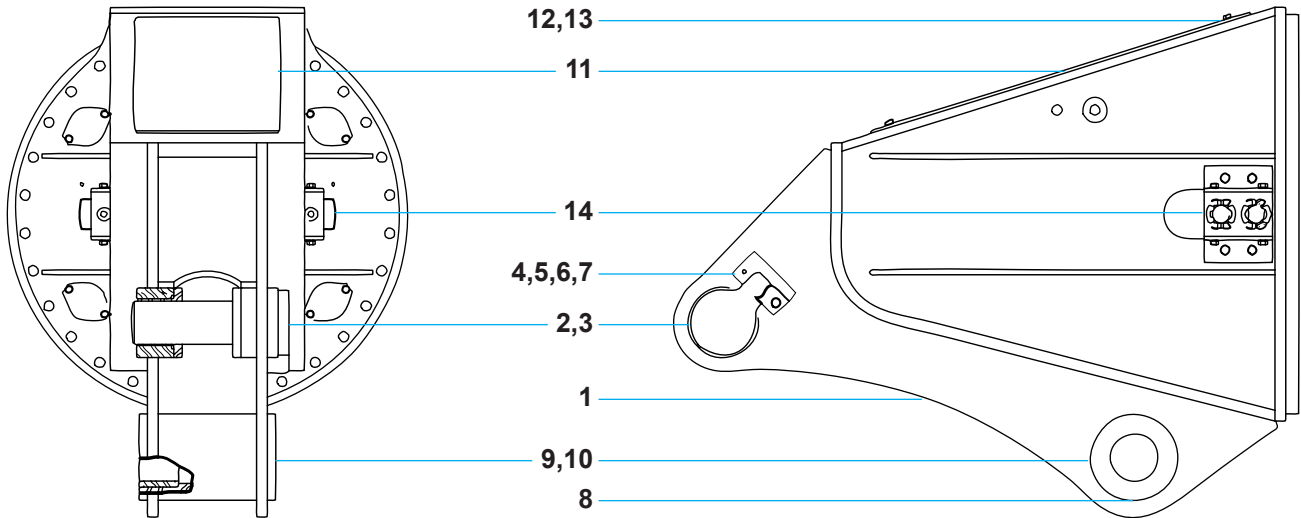

(Boom pin provided by excavator OEM)

Item	Description
1	Upper Head
2	Cylinder Pin
3	Spacer Sleeves
4	Pin Keeper
5	Strap
6	Bolt (hex head capscrew)
7	Lock Washer
8	Grease Fitting
9	Boom Bearings
10	Machine Bearings, where used
11	Inspection/Access Cover
12	Bolt (hex head capscrew)
13	Flat Washer
14	Port Block Assembly

Custom parts - call the Genesis Parts Department, 715-395-3488, for part numbers specific to your serial number.

# PARTS

## Third-Member Mount Upper Head

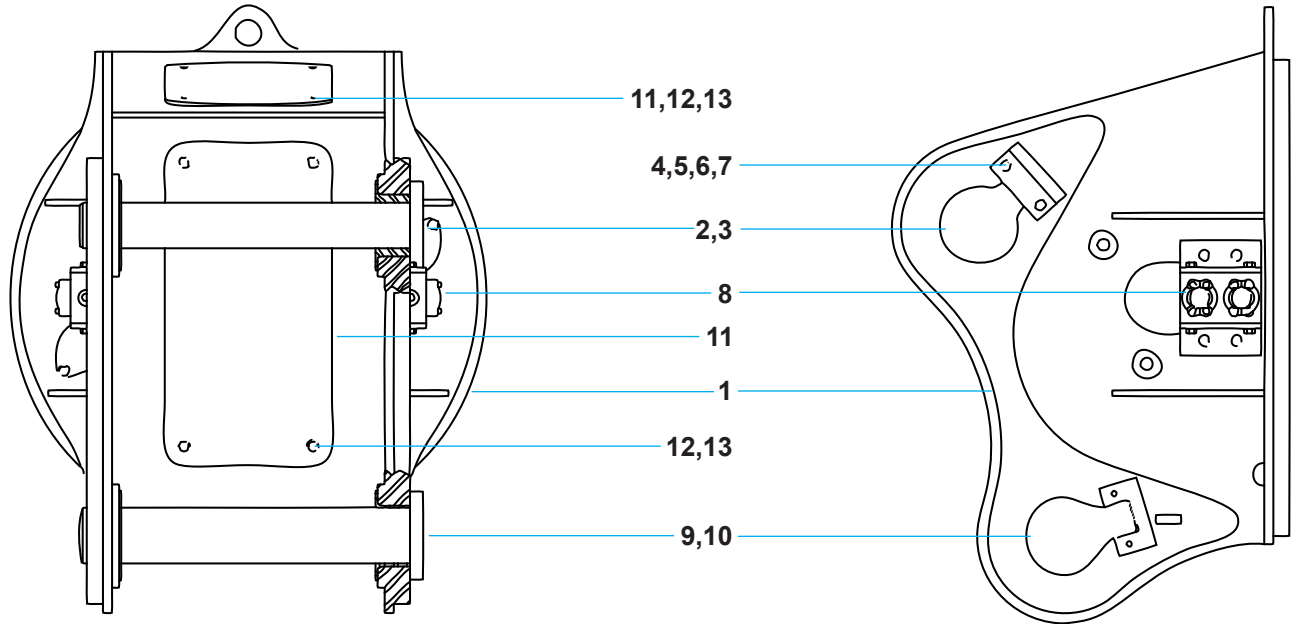

Item	Description
1	Upper Head
2	Cylinder Link Pin
3	Spacer Sleeves, where used
4	Pin Keeper
5	Strap
6	Bolt (hex head capscrew)
7	Lock Washer
8	Port Block Assembly
9	Bearings and/or Spacer Sleeves, where used
10	Stick Pin
11	Inspection/Access Cover
12	Bolt (hex head capscrew)
13	Flat Washer

Custom parts - call the Genesis Parts Department, 715-395-3488, for part numbers specific to your serial number.

## PARTS

### Stick / Body

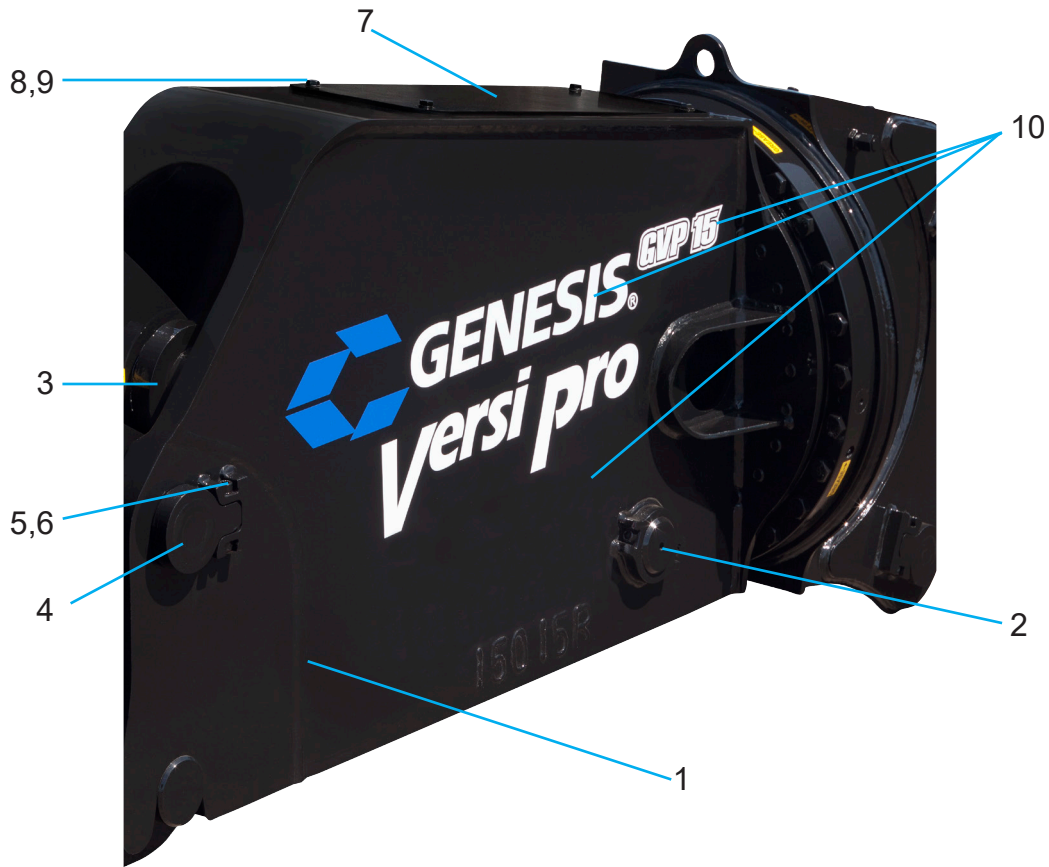

Item	Qty	Part Number	Description
1	1	3501224	Stick
2	1	3501252	Rear Cylinder Pin
3	1	3501251	Front Cylinder Pin
4	1	3201255	Jaw Connection Pin
5	3	F0612110 (rear cyl pin) F0612070 (front cyl & jaw pins)	Pin Bolts, M12 x 1.75 x 110 (Rear) M12 x 1.75 x 70 (Front & Jaw)
6	3	F1012175	Pin Nuts
7	1	3501253	Access Cover
8	4	F0110030	Cover Bolts, M10 x 1.5 x 30
9	4	F1201021	Cover Washers
10	1	6400209	GVP 15 Decal Kit

# PARTS

## Shear Jaw Set

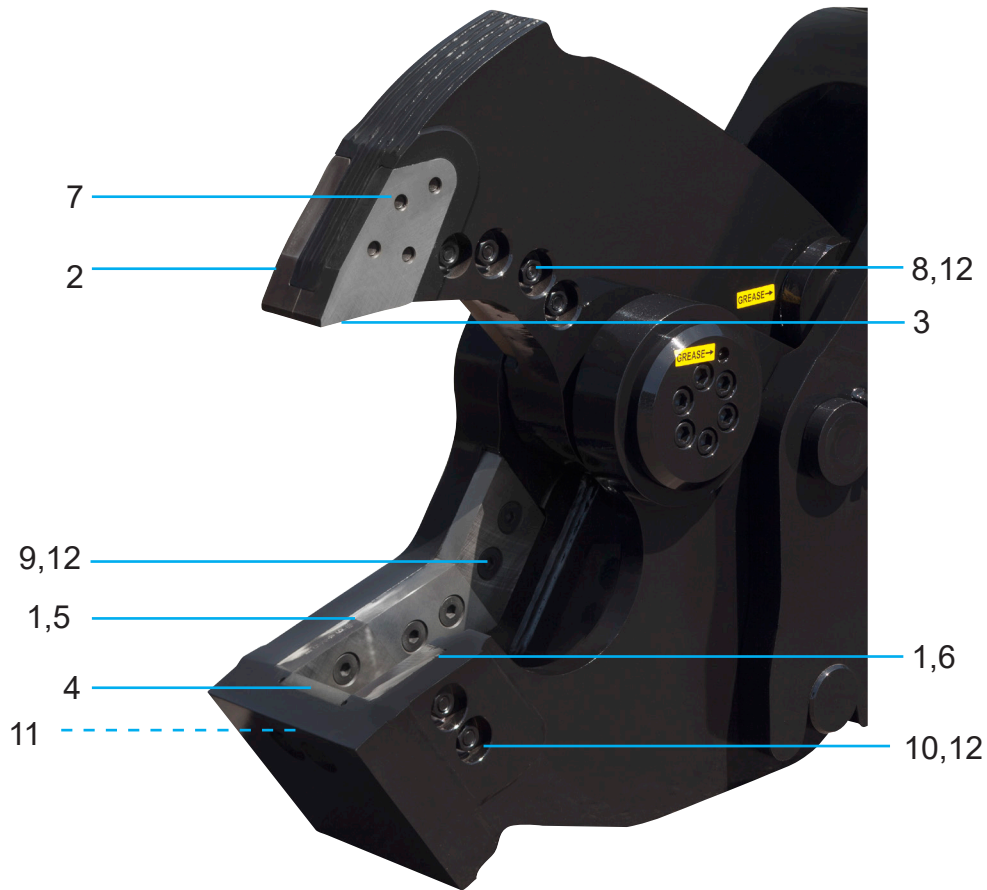

Item	Qty	Part Number	Description
1	6	4500398	Upper and Lower Blades and Guide Blades
2	1	4500394	RH Tip Blade
3	1	4500395	LH Tip Blade
4	1	4500399	Razor Blade
5	1	4500470	Blade Shims
6	1	3501260	Guide Shims
7	4	F0775300	Tip Blade Bolts, $\frac{3}{4}$ " - 10 x 3
8	4	F0575350	Upper Blade Bolts, $\frac{3}{4}$ " - 10 x $3\frac{1}{2}$
9	6	F0575300	Lower Blade and RH Guide Blade Bolts, $\frac{3}{4}$ " - 10 x 3
10	2	F0575250	LH Guide Blade Bolts, $\frac{3}{4}$ " - 10 x $2\frac{1}{2}$
11	2	F0275125	Razor Blade Bolts, $\frac{3}{4}$ " - 10 x $1\frac{1}{4}$
12	12	F0907510	Hex Nuts $\frac{3}{4}$ - 10

# PARTS

## Cracker Jaw Set

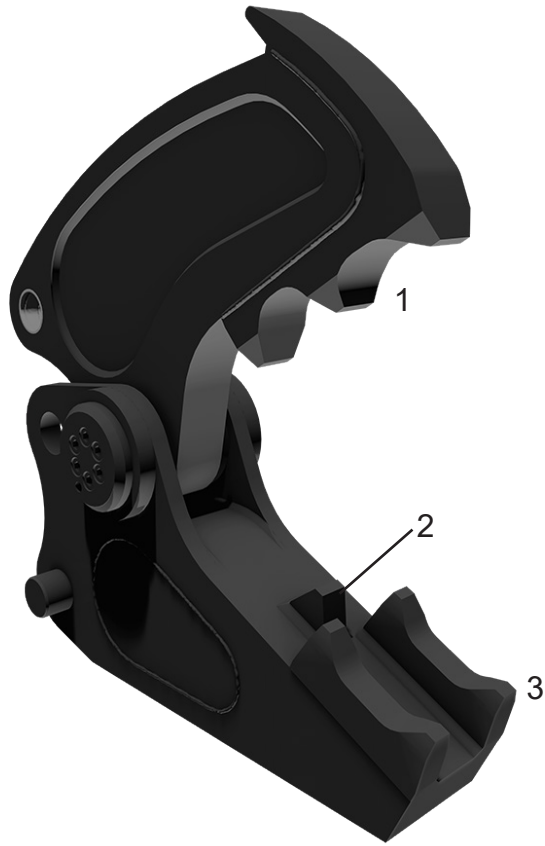

Item	Qty	Part Number	Description
1	1	3501204	Weld-on Upper Teeth
2	1	3501222	Weld-on Lower Teeth (Single)
3	2	3501215	Weld-on Lower Teeth (Double)

# PARTS

## Hydraulics

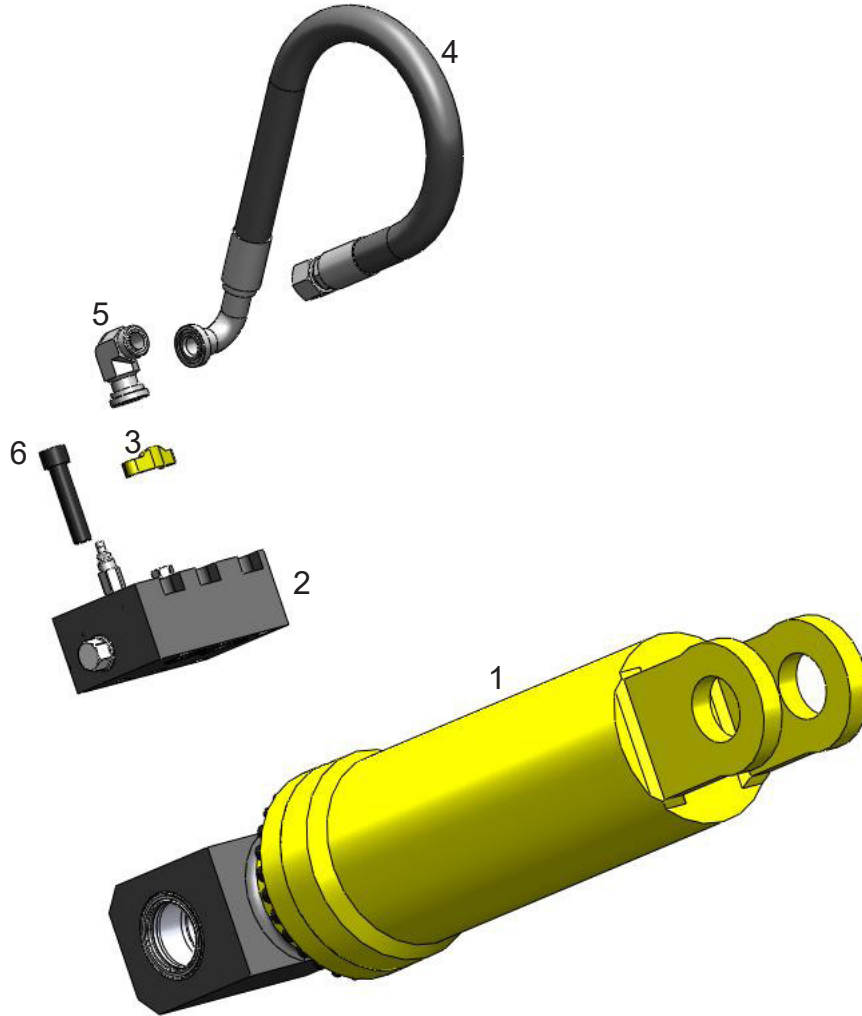

Item	Qty	Part Number	Description
1	1	6350026	Cylinder
2	1	6360004	Regeneration Valve
3	4	H0261100	Split Flange
4	2	5300386	Hose
5	2	6310004	Adapter
6	6	F0620090	Bolt M20 x 2.5 x 90

# PARTS

## Rotation Drive System

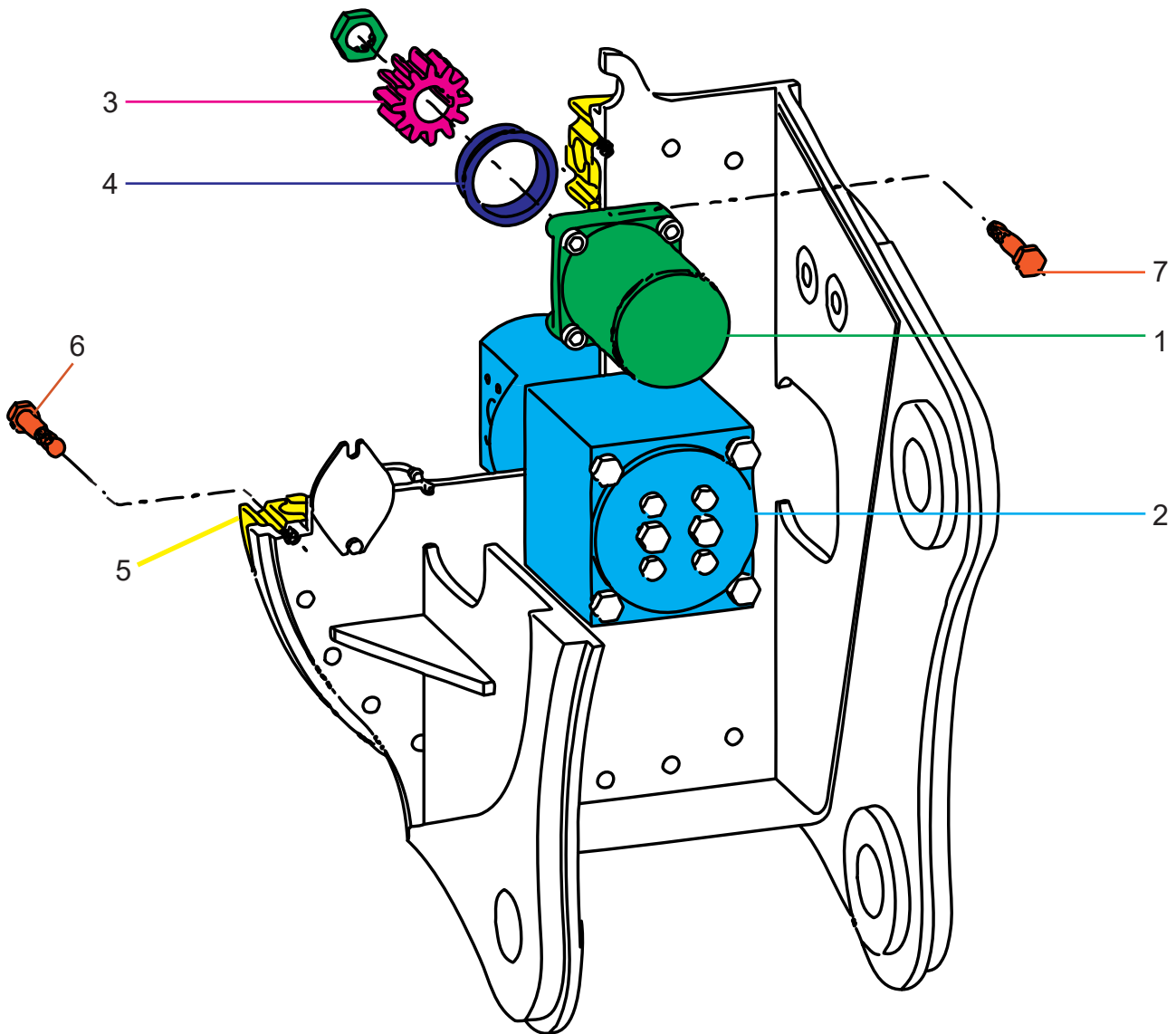

Item	Qty	Part Number	Description
1	1	6380100	Motor
2	1	5410015	Swivel Assembly
3	1	3502192	Pinion
4	1	1107014	Spacer
5	1	6100092	Rotation Bearing
6	30	F0120100	Bolts M20 x 2.5 x 100
7	36	F0120090	Bolts M20 x 2.5 x 90

## BOLT TORQUE SPECIFICATIONS

Reference the product Thread Treatment Diagrams beginning on page 58 to determine whether to use wet or dry torque values for specific bolts.

Reference Procedures on page 60 for threadlocker or anti-seize application and bolt and bolt hole cleaning.

Prior to torquing, clean all bolt holes, bolts and nuts to remove dirt, grease and oil, and identify bolt type.

Never re-torque bolts that use Loctite. If a bolt becomes loose or damaged after the initial use when Loctite was applied and the bolt was torqued, the bolt must be replaced.

Never break tightened bolts loose with a torque wrench. Doing so may break the torque wrench or take it out of calibration.

Torque wrenches should be calibrated on an annual basis.

When using a torque multiplier with a torque wrench, incorrect settings will be multiplied by the ratio of the torque wrench.

Never use an impact driver on a torque multiplier.

# THREAD TREATMENT DIAGRAM

## Mobile Shears

Use this diagram to determine what thread treatment, if any, is required for each fastener.  
 For thread treatment application procedures, see page 60. For prescribed torque values, see page 62.

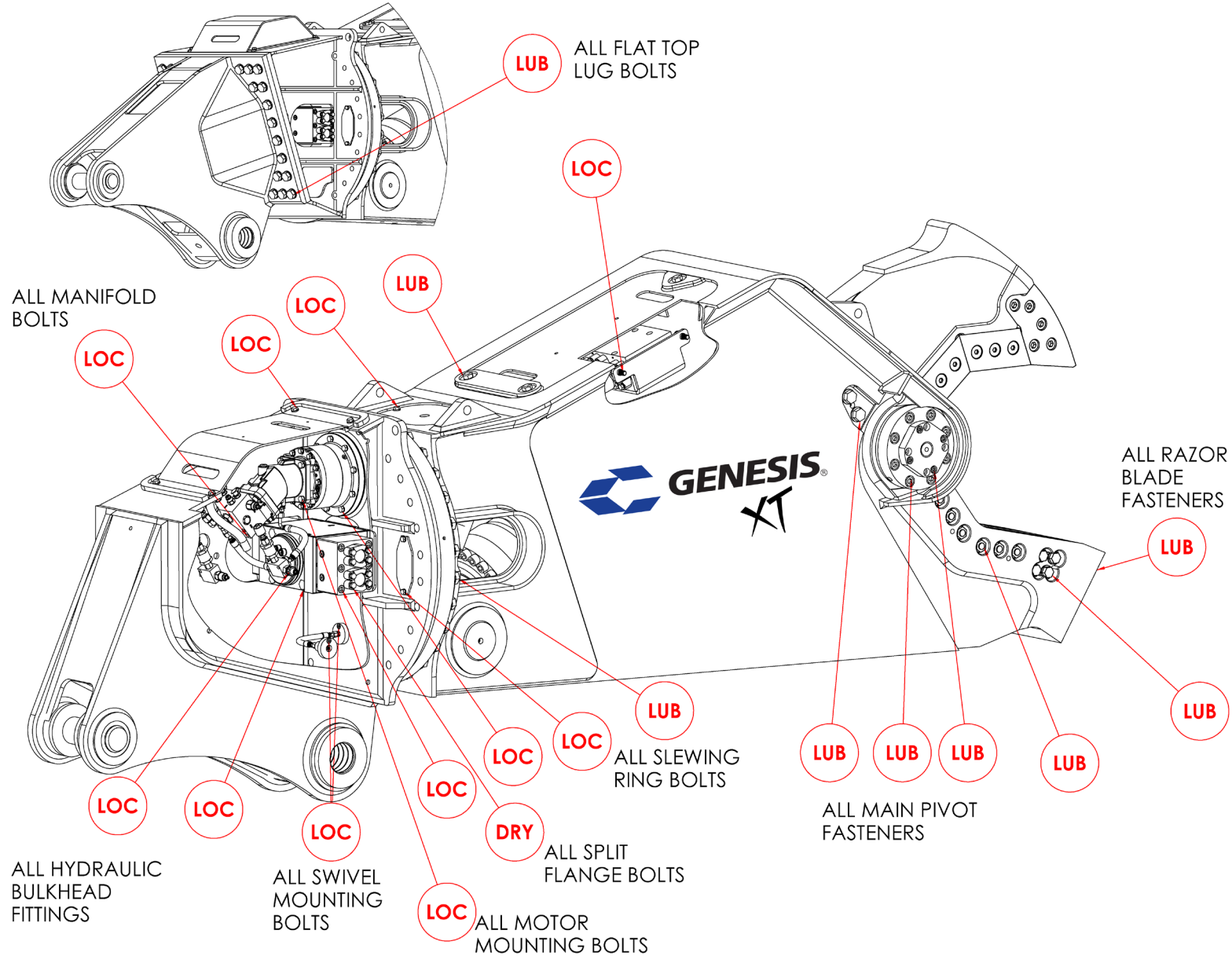

# THREAD TREATMENT DIAGRAM

## Processors

Use this diagram to determine what thread treatment, if any, is required for each fastener.

For thread treatment application procedures, see page 60. For prescribed torque values, see page 62.

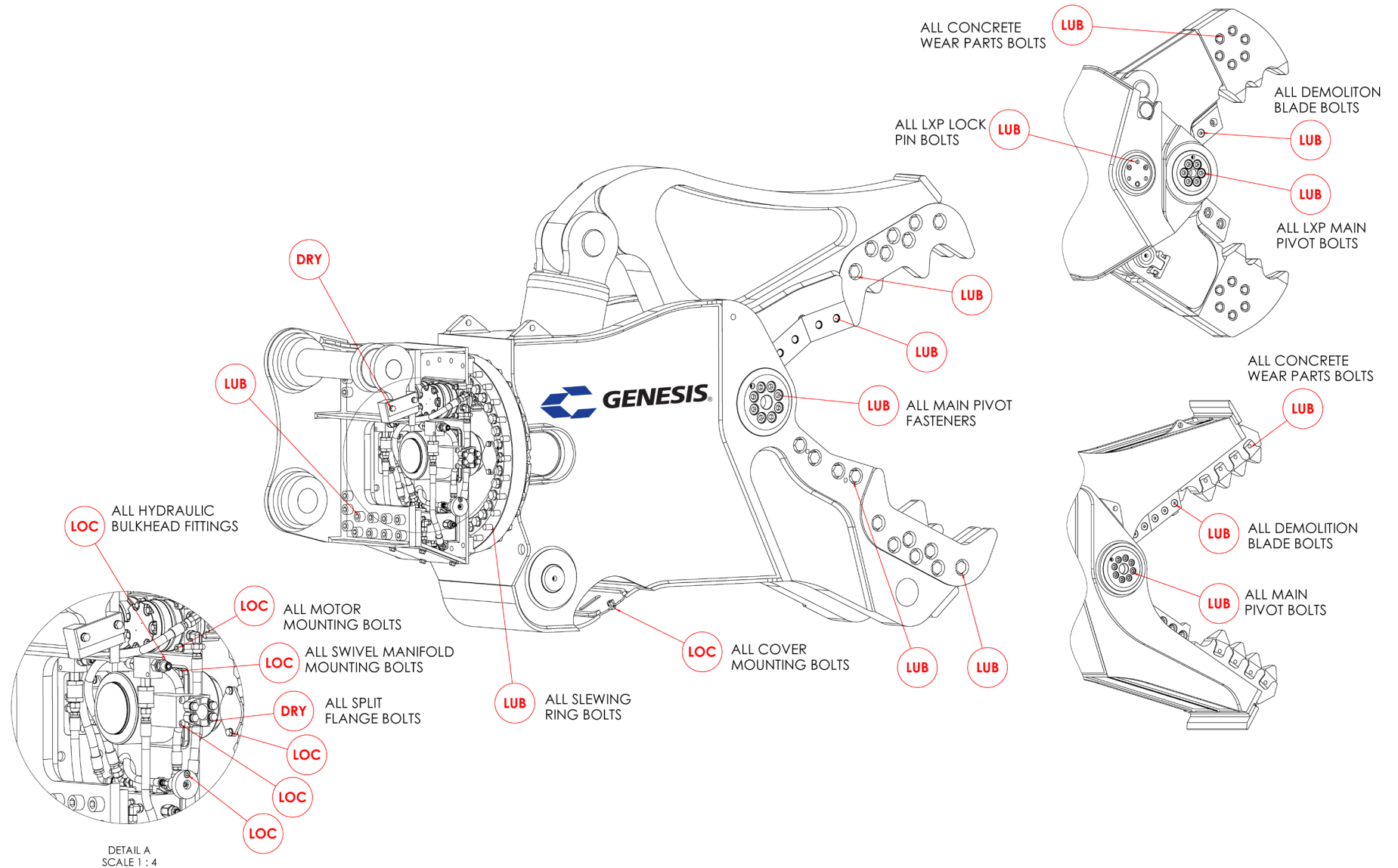

## PROCEDURES

Reference the product Thread Treatment Diagrams beginning on page 58 to determine which of the following procedures is required.

### Cleaning

To ensure proper performance of thread treatment and accurate torque values, clean and degrease **all internal and external threads** prior to application of threadlocker, anti-seize or primer and before installation of hardware.

- Ensure both internal and external threads are free of dirt or debris.
- Use brake cleaner or similar cleaning solvent on all threads to remove any grease or oil.
- Allow threads to dry.

## NOTICE

Failure to properly clean threads will cause threadlocker, primer, and/or anti-seize to not properly cure!

LOC

### Threadlocker

For bolted connections requiring threadlocker, use **Loctite 263** or equivalent applied using the following procedure:

- Clean and degrease all threads.
- For thru holes or nuts, apply threadlocker to bolt threads.
- For blind holes, apply stripe of threadlocker along the length of the hole (applying to the bolt can cause escaping air to remove threadlocker as the bolt is inserted).
- Torque bolt to specified **Wet Torque Value**, see page 62.

For threaded hydraulic fitting connections, use **Loctite 5452** or equivalent thread sealant in conjunction with **Loctite 7471** primer using the following procedure:

- Clean and degrease all threads.
- Apply Loctite 7471 primer to both external and internal threads and allow to dry.
- Apply threadlocker to 360 degrees of the threads on the male fitting, ensuring adequate coverage.
- Assemble fitting per directions in operator's manual.
- For O-ring boss and flat face O-ring connections, torque fittings to values specified on page 63.

Threadlocker

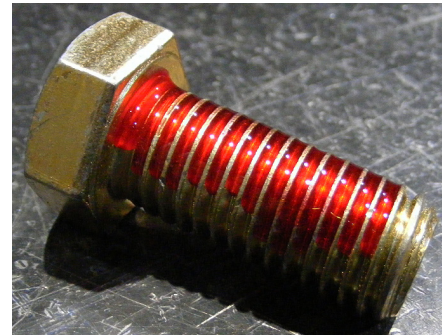

Blind Hole

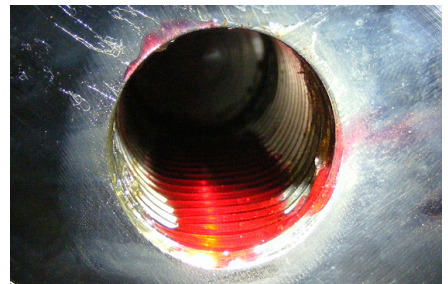

Hydraulic Fitting



## PROCEDURES

LUB

### Anti-Seize

For bolted connections requiring anti-seize lubrication, use **Loctite LB8008** or equivalent using the following procedure:

- Clean and degrease all threads.
- Apply thin coat of anti-seize to internal and external threads and under bolt head and/or nut, ensuring complete coverage.
- Torque bolt to specified **Wet Torque Value**, see page 62.

Anti-Seize







DRY

### No Thread Treatment

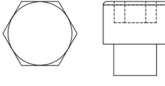
- Clean and degrease all threads.
- Torque bolt to specified **Dry Torque Value**, see page 62.

# BOLT TORQUE SPECIFICATIONS

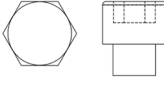
<b>Dry Torque Values</b>					
		<b>Hex/Socket Head</b>		<b>Flat Head</b>	
					
Fastener Grade	Size x Pitch	Nm	Ft-lb	Nm	Ft-lb
CL 10.9	M8 x 1.25	35	26	27	20
	M10 x 1.50	71	53	58	42
	M12 x 1.75	124	92	101	73
	M14 x 1.50	200	148	163	118
	M14 x 2.00	200	148	163	118
	M16 x 2.00	311	230	254	184
	M20 x 1.50	610	450	498	360
	M20 x 2.50	608	449	497	359
	M24 x 3.00	1054	778	861	622
	M27 x 3.00	1543	1138	1260	910
	M30 x 3.50	2095	1545	1712	1236
	M36 x 4.00	3659	2699	2991	2159
8	1/4-20	14	11	11	8
	5/16-18	32	24	26	19
	3/8-16	59	44	48	35
	7/16-14	94	70	77	56
	1/2-13	143	106	116	84
	1/2-20	162	120	133	96
	5/8-11	287	212	234	169
	3/4-10	509	376	415	300
	7/8-9	821	606	670	484
	1.00-8	1232	909	1007	727
	1.00-14	1383	1020	1130	816
	1.25-7	2463	1817	2013	1453
8/L9	1.50-6	4287	3162	3504	2529

<b>Wet Torque Values</b>					
		<b>Hex/Socket Head</b>		<b>Flat Head</b>	
					
Fastener Grade	Size x Pitch	Nm	Ft-lb	Nm	Ft-lb
CL 10.9	M8 x 1.25	29	22	23	17
	M10 x 1.50	61	45	49	36
	M12 x 1.75	105	78	85	62
	M14 x 1.50	150	111	121	88
	M14 x 2.00	170	126	138	100
	M16 x 2.00	265	196	216	156
	M20 x 1.50	456	337	372	269
	M20 x 2.50	517	382	422	305
	M24 x 3.00	894	660	731	528
	M27 x 3.00	1312	968	1072	774
	M30 x 3.50	1779	1312	1453	1049
	M36 x 4.00	3110	2294	2542	1835
8	1/4-20	13	10	11	8
	5/16-18	27	20	22	16
	3/8-16	50	37	40	29
	7/16-14	80	59	65	47
	1/2-13	122	90	99	72
	1/2-20	138	102	112	81
	5/8-11	244	180	199	144
	3/4-10	433	320	354	256
	7/8-9	698	515	570	412
	1.00-8	1046	772	854	617
	1.00-14	1175	867	960	693
	1.25-7	2095	1545	1712	1236
8/L9	1.50-6	3644	2688	2979	2150

## O-RING BOSS & FLAT FACE O-RING TORQUE SPECIFICATIONS

<b>O-Ring Boss Torque Values</b>		
Size Dash	Nm	Ft-lb
-4	22	16
-5	27	20
-6	36	26
-8	83	60
-10	110	80
-12	187	135
-14	249	180
-16	304	220
-20	387	280
-24	498	360

<b>Flat Face O-Ring Torque Values</b>		
Size Dash	Nm	Ft-lb
-4	18	13
-6	30	22
-8	60	44
-10	85	62
-12	121	88
-14	121	88
-16	160	116
-20	213	154
-24	274	198

# BOLT DRIVE SPECIFICATIONS

Thread Size x Pitch	Hex Head	Socket Head	Flat Head
			
<b>Wrench/Drive Size</b>			
M8 x 1.25	13mm	6mm	5mm
M10 x 1.50	17mm	8mm	6mm
M12 x 1.75	19mm	10mm	8mm
M14 x 1.50	22mm	12mm	10mm
M14 x 2.00	22mm	12mm	10mm
M16 x 2.00	24mm	14mm	10mm
M20 x 1.50	30mm	17mm	12mm
M20 x 2.50	30mm	17mm	12mm
M24 x 3.00	36mm	19mm	14mm
M27 x 3.00	41mm	19mm	-
M30 x 3.50	46mm	22mm	-
M36 x 4.00	55mm	27mm	-
1/4-20	7/16"	3/16"	5/32"
5/16-18	1/2"	1/4"	3/16"
3/8-16	9/16"	5/16"	7/32"
7/16-14	5/8"	3/8"	1/4"
1/2-13	3/4"	3/8"	5/16"
1/2-20	3/4"	3/8"	5/16"
5/8-11	15/16"	1/2"	3/8"
3/4-10	1-1/8"	5/8"	1/2"
7/8-9	1-5/16"	3/4"	9/16"
1.00-8	1-1/2"	3/4"	5/8"
1.00-14	1-1/2"	3/4"	5/8"
1.25-7	1-7/8"	7/8"	7/8"
1.50-6	2-1/4"	1"	1"

## TOOL LIST

The following is a list of tools available for purchase from Genesis. This list may not include every tool used for this attachment, such as those that would also commonly be used for maintaining an excavator.

Part Number	Description
6900016	BHWBW-1167FP 7/8" COMBINATION WR 12 PT
6900017	BHWBW-1172FP 1 1/8" COMBINATION WR 12 PT
6900028	7/16" COMBINATION WR 12PT
6900029	1/2" COMBINATION WR 12PT
6900030	9/16" COMBINATION WR 12PT
6900031	11/16" COMBINATION WR 12PT
6900032	3/4" COMBINATION WR 12PT
6900033	13/16" COMBINATION WR 12PT
6900034	3/4" 6PT SOCKET (1/2" DRIVE)
6900035	15/16" COMBINATION WR 12PT
6900036	#2 FLAT SCREWDRIVER
6900037	1 3/8" COMBINATION WR 12PT
6900038	1 1/2" COMBINATION WR 12PT
6900039	1 5/8" COMBINATION WR 12PT
6900040	18mm COMBINATION WR 12PT
6900041	19mm COMBINATION WR 12PT
6900042	22mm COMBINATION WR 12PT
6900043	36mm COMBINATION WR 12PT
6900044	3/8' RATCHET DRIVE
6900045	1/2' RATCHET DRIVE
6900046	3" DRIVE EXTENSION (3/8" DRIVE)
6900047	6" DRIVE EXTENSION (3/8" DRIVE)
6900048	9" DRIVE EXTENSION (3/8" DRIVE)
6900049	7/16" 12PT SOCKET (3/8" DRIVE)
6900050	1/2" 12PT SOCKET (3/8" DRIVE)
6900051	9/16" 12PT SOCKET (3/8" DRIVE)
6900052	3/4" 12PT SOCKET (3/8" DRIVE)
6900053	6mm ALLEN SOCKET (3/8" DRIVE)
6900054	14mm ALLEN SOCKET (3/8" DRIVE)
6900055	10 PIECE SAE ALLEN WR SET (1/16-3/8")
6900056	10 PIECE MM ALLEN WR SET (1.5-10mm)



**GENESIS®**

The Promise of Performance.

## CONTACT INFORMATION

### Genesis Attachments

1000 Genesis Drive  
Superior, WI 54880 USA

Toll Free: 888-SHEAR-IT  
(888-743-2748)

Phone: 715.395.5252

E-mail:  
info@genesisattachments.com

### Europe/Africa/Middle East Genesis GmbH

Teramostrasse 23  
87700 Memmingen, Germany

Phone: +49 83 31 9 25 98 0

Fax: +49 83 31 9 25 98 80  
genesis-europe.com

E-mail:  
info@genesis-europe.com

### Asia Pacific Representative Office

24 Upper Serangoon View #12-28  
Singapore 534205

Phone: +65 9673 9730

E-mail:  
tchoo@genesisattachments.com

### Central America & Colombia

Cra 13A #89-38 / Ofi 613  
Bogota, Colombia

Phone: +57 1 610 8160 / 795 8747

E-mail:  
contact@themsagroup.com

View and download all manuals: [genesisattachments.com/manuals](http://genesisattachments.com/manuals)  
Patents: [genesisattachments.com/products/patents](http://genesisattachments.com/products/patents)