



Demolition Recycler (GDR)

SAFETY, OPERATOR'S AND PARTS MANUAL



CONTACT INFORMATION

Genesis Attachments

1000 Genesis Drive
Superior, WI 54880 USA

Toll Free: 888-SHEAR-IT
(888-743-2748)

Phone: 715.395.5252

E-mail:
info@genesisattachments.com

Europe/Africa/Middle East Genesis GmbH

Teramostrasse 23
87700 Memmingen, Germany

Phone: +49 83 31 9 25 98 0
Fax: +49 83 31 9 25 98 80
genesis-europe.com

E-mail:
info@genesis-europe.com

Asia Pacific Representative Office

24 Upper Serangoon View #12-28
Singapore 534205

Phone: +65 9673 9730

E-mail:
tchoo@genesisattachments.com

Central America & Colombia

Cra 13A #89-38 / Ofi 613
Bogota, Colombia

Phone: +57 1 610 8160 / 795 8747

E-mail:
contact@themsagroup.com

View and download all manuals: genesisattachments.com/manuals
Patents: genesisattachments.com/products/patents

PREFACE

To ensure years of safe, dependable service, only trained and authorized persons should operate and service your Genesis attachment. It is the responsibility of the product's owner to ensure the operator is trained in the safe operation of the product and has available this manual for review. It is the responsibility of the operator and maintenance personnel to read, fully understand and follow all operational and safety-related instructions in this manual. The attachment should not be operated until you have read and fully understand these instructions. Always use good safety practices to protect yourself and those around you.

Important

This operator's manual must accompany the attachment at all times and be readily available to the operator.

Manual Replacement

Should this manual become damaged or lost or if additional copies are required, immediately contact any authorized Genesis dealer or the Genesis Service Department at 888-743-2748 or 715-395-5252 for a replacement.

Registration Form

The Warranty Registration Form must be filled out by the dealer or customer and returned to Genesis indicating the date the attachment went into service.

Possible Variations

Genesis cannot anticipate every possible circumstance that might involve a potential hazard as the owner's requirements and equipment may vary. Therefore, the warnings in this publication and on the product may not be all-inclusive, and you must satisfy yourself that the procedure, application, work method or operating technique is safe for you and others before operating.

Public Notice

Genesis reserves the right to make changes and improvements to its products and technical literature at any time without public notice or obligation. Genesis also reserves the right to discontinue manufacturing any product at its discretion at any time.

Warranty

All work or repairs to be considered for warranty reimbursement must be pre-authorized by the Genesis Service Department. Any alterations, modifications or repairs performed before authorization by the Genesis Service Department will render all warranty reimbursement consideration null and void without exception. See page 49 for Warranty Claim Procedures.

Improper operation or improperly performed maintenance may render any warranty null and void.

TABLE OF CONTENTS

CONTACT INFORMATION	2
PREFACE	3
Important	3
Manual Replacement	3
Registration Form	3
Possible Variations	3
Public Notice	3
Warranty	3
SAFETY STATEMENTS	7
OPERATIONAL SAFETY	8
Read Manual Before Operating or Maintaining the Attachment	8
Personal Protection	8
Know Your Equipment	8
Before Operating	8
Check the Equipment	9
Stability	9
Know the Work Area	10
Starting Procedure	10
Place the Load Safely	10
Safely Operate Equipment	11
Transporting the Attachment	12
Equipment Condition	12
Working Overhead	12
Power Lines	12
Use Care with Hydraulic Fluid Pressure	13
Prioritized Oil Flow	14
Emergency Situations	14
Unsafe Conditions	14
Crystalline Silica Dust	14
Prop. 65 Warning for California Residents	14
Process Material Safely	15
Lift the Load Safely	15
Place the Load Safely	15
ATTACHMENT MARKINGS	16
TRANSPORT ROTATION LOCK	17
ATTACHMENT INSTALLATION	18
Installation Procedure	18
ROTATOR INSTALLATION	19
Foot Switch Installation	19
Rotation Circuit - Gear Pump Type	20
Rotation Circuit - Auxiliary Valve on Machine	21
HYDRAULIC START-UP	22
Start-up Procedure	22
GENERAL OPERATION INSTRUCTIONS	23
Start-up	23
Efficient and Productive Operation	23

TABLE OF CONTENTS

COMMON OPERATIONAL CONCERNS	24
Cutting Larger Materials	24
Chatter While Cutting	24
MAINTENANCE SAFETY	25
MAINTENANCE SCHEDULE	27
Four-Hour Checklist	27
Eight-Hour Checklist	27
Long-term Maintenance	27
LUBRICATION POINTS	28
TOOTH AND BLADE MAINTENANCE	29
Pulverizing Teeth	29
Cutting Blades	30
Blade Removal	30
Blade Rotation	30
Blade Gap	31
Blade Gap Measuring Procedure	31
Shimming Procedure	31
GENERAL WELDING GUIDELINES	32
Welding Ground Clamp	32
Welding Rules	32
BUILD-UP AND HARD-SURFACING	33
Hard-Surfacing Patterns	33
HARD-SURFACING	34
HYDRAULIC/ROTATION MAINTENANCE	35
Hydraulic Requirements	35
Rotation Valve Settings	35
GenFlow Regeneration Valve	36
Regeneration Valve Adjustment	36
GENFLOW REGENERATION VALVE - HOW IT WORKS	37
GENFLOW REGENERATION VALVE	38
GDR 150/200/300	38
GDR 400	39
SLEWING RING MAINTENANCE	40
ROTATION CIRCUIT	41
Rotation with Motion Control Valve	42
Flow Divider Rotation	43
Gear Pump Rotation	44
GDR 400 MOTOR REPLACEMENT	45
TROUBLE-SHOOTING GUIDE	46
WARRANTY	49
Claim Procedure	49
Blade Warranty	49

TABLE OF CONTENTS

PARTS ORDER POLICY AND PROCEDURE	50
Parts Orders Should Include.....	50
Placing Orders.....	50
Part Numbers.....	50
Shipping.....	50
Invoices.....	50
Returns.....	50
Warranty Returns.....	50
PARTS ORDER FORM	51
PARTS	52
Third-member Mount Upper Head.....	53
GDR 150/200 Cracker Jaw Configuration.....	54
GDR 300/400 Cracker Jaw Configuration.....	55
GDR 150/200 Pulverizer Jaw Configuration.....	56
GDR 300/400 Pulverizer Jaw Configuration.....	57
GDR 150/200 Shear Jaw Configuration.....	58
GDR 300 Shear Jaw Configuration.....	59
GDR 150 Pivot and Pins.....	60
GDR 200 - 400 Pivot and Pins.....	61
GDR 150 Cylinder Assembly.....	62
GDR 200 Cylinder Assembly.....	63
GDR 300 Cylinder Assembly.....	64
GDR 400 Cylinder Assembly.....	65
Rotation Drive System.....	66
TOOL LIST	69
BOLT TORQUE SPECIFICATIONS	70
THREAD TREATMENT DIAGRAM	71
Processors.....	71
PROCEDURES	72
Cleaning.....	72
Threadlocker.....	72
Anti-Seize.....	73
No Thread Treatment.....	73
BOLT TORQUE SPECIFICATIONS	74
Dry Torque Values.....	74
Wet Torque Values.....	74
O-RING BOSS & FLAT FACE O-RING TORQUE SPECIFICATIONS	75
BOLT DRIVE SPECIFICATIONS	76
CONTACT INFORMATION	77

SAFETY STATEMENTS



This symbol by itself or used with a safety signal word throughout this manual is used to call attention to instructions involving your personal safety or the safety of others. Failure to follow these instructions can result in injury or death.



This statement is used where serious injury or death will result if the instructions are not followed properly.



This statement is used where serious injury or death could result if the instructions are not followed properly.



This statement is used where minor or moderate injury could result if the instructions are not followed properly.

NOTICE

This statement is used where property damage could result if the instructions are not followed properly.

OPERATIONAL SAFETY

Read Manual Before Operating or Maintaining the Attachment



Read this manual before attempting to operate the attachment. This operator's manual should be regarded as part of the attachment. For proper installation, operation and maintenance of the attachment, operators and maintenance personnel must read this manual.



WARNING

Serious injury or death could result if appropriate protective clothing and safety devices are not used.

Personal Protection

Use protective clothing and safety devices appropriate for the working conditions. These may include but are not limited to:

- ✓ Hard hat
- ✓ Safety glasses, goggles or face shield
- ✓ Hearing protection
- ✓ Safety shoes
- ✓ Heavy gloves
- ✓ Reflective clothing
- ✓ Respirator or filter mask



Safety matters

Know Your Equipment



Know your attachment's capabilities, dimensions and functions before operating. Inspect your attachment before operating and never operate an attachment that is not in proper working order. Remove and replace any damaged or worn parts.

Before Operating

- ✓ Warn all others in the area that you are about to start operation.
- ✓ Perform the Check the Equipment steps outlined in this manual.
- ✓ Check underneath and around the machine. Make sure all personnel and equipment are clear from the area of operation and equipment movement. Check clearances in all directions, including overhead.
- ✓ Be properly seated in the operator's seat.
- ✓ Do not attempt to operate until you have read and fully understand this manual and the OEM manual for the carrier.

OPERATIONAL SAFETY

Check the Equipment

Before use, check the equipment to ensure it is in good operating condition.

Check the following:

- ✓ Grease fittings. Pump grease at all fitting locations, see page 28.
- ✓ Hydraulic fluid level. Add hydraulic fluid as required.
- ✓ Hydraulic hoses and hose connections for wear or leaks. Repair or replace any damaged hoses or connections.
- ✓ All control levers for proper operation.
- ✓ Rotation bearing. Visually check for loose or damaged bolts. If repair is required, refer to qualified personnel.
- ✓ Grease rotation bearing and pinion gear.
- ✓ Check for loose or missing pin retaining bolts.
- ✓ Check cylinders for dents (barrel) or dings (rod).



**GOOD
CONDITION**



WARNING

Serious injury or death could result if warnings or instructions regarding carrier stability and the work area are not followed properly.

Stability

Your Genesis attachment is sized for carrier stability. However, improper operation, faulty maintenance or unauthorized modifications may cause instability.

- ✓ Know the working ranges and capacities of the carrier to avoid tipping.
- ✓ Use the recommended carrier counter weight.

The following conditions affect stability:

- Ground conditions
- Grade
- Weight of attachment
- Contents of attachment
- Operator judgement



For greater stability, knuckle the attachment to bring the load closer to the center of rotation (center of gravity) while lifting. Use extra caution during reaching to avoid tipping.

OPERATIONAL SAFETY

Know the Work Area

Check clearances in the work area. Keep all bystanders at a safe distance. Do not work under obstacles. Always check your location for overhead and buried power lines or other utilities before operation.

Check ground conditions. Avoid unstable or slippery areas. Position the carrier on firm level ground. If level ground is not possible, position the carrier to use the attachment to the front or back of the carrier. Avoid working over the side of the carrier.

To reduce the risk of tipping and slipping, never park on a grade exceeding 10% (one-foot rise over the span of a ten-foot run).

Starting Procedure

Before operating, walk completely around the equipment to make certain no one is under it, on it or close to it. Keep all bystanders at least 75 feet away from the area of operation and equipment movement. Let all other workers and bystanders know you are preparing to start. DO NOT operate until everyone is clear.

Always be properly seated in the operator's seat before operating any carrier controls.

To start:

- ✓ Make sure all controls are in the center (neutral) position.
- ✓ Be properly seated.
- ✓ Slowly operate all functions to check for proper operation and to bleed air from the hydraulic system.

To shut down:

- ✓ Return your Genesis attachment to a rest position on the ground.
- ✓ Shut off the carrier engine.
- ✓ Work controls in all directions to relieve hydraulic pressure, per excavator manufacturer's instructions.



WARNING

Serious injury or death could result if warnings or instructions regarding safe operation are not followed properly.

Place the Load Safely

Do not move the attachment, or anything held in the jaws, over people, equipment or buildings. Do not throw or drop the contents. Operate the controls smoothly and gradually.

OPERATIONAL SAFETY

Safely Operate Equipment

Do not operate equipment until you are trained by a qualified operator in its use and capabilities.

See your carrier's manual for these instructions.

- ✓ Operate only from the operator's seat. Check the seat belt daily and replace if frayed or damaged.
- ✓ Do not operate this or any other equipment under the influence of drugs or alcohol. If you are taking prescription medication or over-the-counter drugs ask your medical provider whether you can safely operate equipment.
- ✓ Never leave equipment unattended with the engine running or with the attachment in a raised position. Apply the brakes before exiting the equipment.
- ✓ Do not exceed the lifting capacity of your carrier.
- ✓ Avoid conditions that can lead to tipping. The carrier can tip when operated on hills, ridges, banks and slopes. Avoid operating across a slope which could cause the carrier to overturn.
- ✓ Reduce speed when driving over rough terrain, on a slope, or when turning to avoid overturning the carrier.
- ✓ Never use the attachment as a work platform or personnel carrier.
- ✓ Keep all step plates, grab bars, pedals and controls free of dirt, grease, debris and oil.
- ✓ Never allow anyone to be around the equipment when it is operating.
- ✓ Do not operate poorly maintained or otherwise faulty equipment. Inform the proper authority and DO NOT resume operation until the problem has been fixed.
- ✓ Do not alter or remove any safety features.
- ✓ Know your work site safety rules as well as traffic rules and flow. When in doubt on any safety issue, contact your supervisor or safety coordinator for an explanation.
- ✓ A heavy load can cause equipment instability. Use extreme care during travel. Slow down on turns and watch out for bumps. The equipment may need additional counter-weights to counterbalance the weight of the attachment.



OPERATIONAL SAFETY

Transporting the Attachment

- ✓ Travel only with the attachment in a safe transport position to prevent uncontrolled movement. Drive slowly over rough ground and on slopes.
- ✓ When driving on public roads use safety lights, reflectors, Slow Moving Vehicle signs, etc., to prevent accidents. Check local government regulations that may affect you.
- ✓ Do not drive close to ditches, excavations, etc., as cave-in could result.
- ✓ Do not smoke when refueling the prime mover. Allow room in the fuel tank for expansion. Wipe up any spilled fuel. Secure cap tightly when done.

Equipment Condition

Never operate poorly maintained equipment. When maintenance is required, repair or replace parts immediately.



WARNING

Serious injury or death could result if warnings or instructions regarding working overhead are not followed properly.

Working Overhead

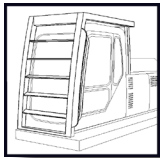

Avoid handling material overhead whenever possible. Safety glass and wire mesh cab guarding must be installed to protect the operator from flying debris that may be created during handling. Falling Object Protection Structures, or FOPS, are necessary for any application where material is to be handled overhead.



DANGER

Serious injury or death will result if warnings or instructions regarding power lines are not followed properly.

Power Lines

Do not operate the machine near energized power lines. All local, state/provincial and federal regulations must be met before approaching power lines, overhead or underground cables, or power sources of any kind with any part of the carrier or attachment. Always contact the appropriate utility when operating near power lines. The lines should be moved, insulated, disconnected or de-energized and grounded before operating in the area.



Current in high voltage lines may arc some distance from the wire to a nearby ground. Keep all parts of the machine at least 50 feet (16m) away from power lines.

OPERATIONAL SAFETY



WARNING

Serious injury or death could result if warnings or instructions regarding hydraulic fluid pressure are not followed properly.

Use Care with Hydraulic Fluid Pressure

Hydraulic fluid under pressure can penetrate the skin and cause serious injury or death. Hydraulic leaks under pressure may not be visible.

- ✓ Keep unprotected body parts, such as face, eyes and arms as far away as possible from a suspected leak. Flesh injected with hydraulic fluid may develop gangrene or other permanent injuries.
- ✓ If injured by injected fluid see a doctor immediately.
- ✓ Wear safety glasses and protective clothing and use a piece of cardboard or wood when searching for hydraulic leaks.

Do Not Use Your Hands!
See illustration below.

- ✓ Hydraulic oil becomes hot during operation. Do not let hydraulic oil or components contact skin, as it could cause severe burns. Allow hydraulic components to cool before working on them. Use appropriate protective clothing and safety equipment. If burned, seek immediate medical attention.

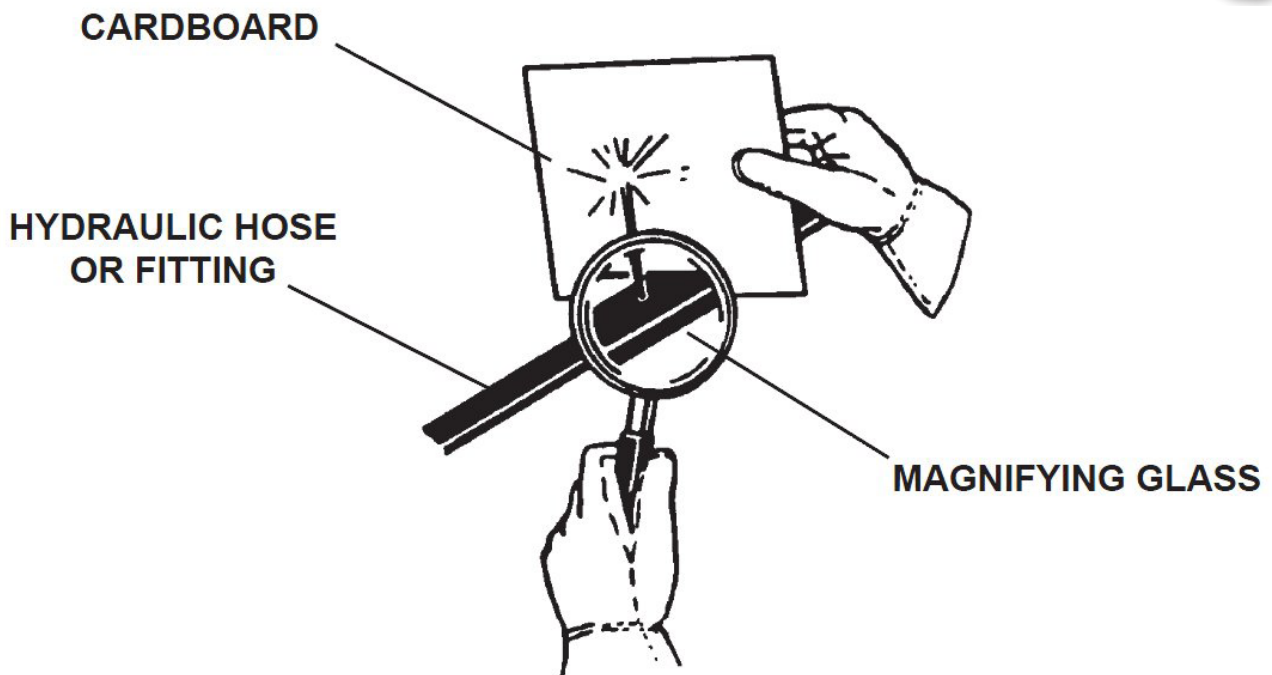
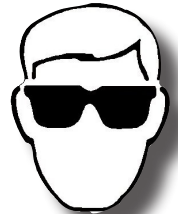

OPERATIONAL SAFETY

Prioritized Oil Flow

Equipment operators must ensure there is prioritized oil flow to the main valves in overhead operations or high reach conditions.

Emergency Situations

Always be prepared for emergencies. Make sure a fire extinguisher is available. Be familiar with its operation. Make sure to inspect and service the fire extinguisher regularly. Make sure a first aid kit is readily available.



Unsafe Conditions

Do not operate if an unsafe condition exists. Stop operation immediately, shut down the machine and report the unsafe condition to the proper authority. Equipment operation and maintenance practices directly affect your safety and the safety of those around you. Always use common sense while operating and be alert to unsafe conditions.

Crystalline Silica Dust

It is recommended to use dust suppression, dust collection and if necessary, personal protective equipment during the operation of any attachment that may cause high levels of dust.



DANGER

Exposure to respirable crystalline silica dust along with other hazardous dusts may cause serious or fatal respiratory disease.

IMPORTANT: Concrete and masonry products contain silica sand. Quartz, which is a form of silica and the most common mineral in the Earth's crust, is associated with many types of rock.

Some activities that may have silica dust present in the air include demolition, sweeping, loading, sawing, hammering, drilling or planing of rock, concrete or masonry.

It is recommended to use dust suppression (such as water) or dust collection (such as a vacuum) along with personal protective equipment if necessary during the operation of any attachment that may cause high levels of silica dust.



Prop. 65 Warning for California Residents



WARNING

This product may contain chemicals known to the State of California to cause cancer, birth defects, or other reproductive harm. For more information visit: P65Warnings.ca.gov

OPERATIONAL SAFETY



WARNING

Using your Genesis attachment in unauthorized applications may create an unsafe situation and will void the warranty.

Process Material Safely

- Do not process hardened steel material such as tool steel, railroad rail, axles, springs, machined parts or high-strength material. Hardened/high-strength material breaks, rather than shears, which may cause flying debris. It will also cause damaging decompression spikes to your Genesis attachment and base carrier hydraulic systems.
- Do not operate any functions of the carrier while cutting or crushing with your attachment, including boom and drive functions.
- Do not pull down structures with your Genesis attachment. Doing so may cause falling debris or material to break free and exceed the capacities of the carrier, causing a tipping hazard and rotation component failures.
- Do not use rotation to pry or break material. Doing so exerts high back-driving forces and spikes to the rotation circuit components that cannot be cushioned hydraulically. It may also cause motor and gearbox failures. The rotator should only be used for positioning an attachment.
- Do not process pressurized containers unless the main valve has been removed and you are absolutely certain the container is empty.
- Do not process spring loaded brake chambers and automotive struts as the release of compressed springs is extremely dangerous. Nothing made of spring material or containing springs should be processed.

Lift the Load Safely

- The hydraulic system has been preset and tested by your dealer. Do not alter hydraulic settings without consulting an authorized Genesis dealer or the Genesis Service Department. Doing so will void the warranty and may cause structural damage, accidents or tipping.
- Make sure the load is held securely in the jaws. Do not move a loaded attachment if load is loose or dangling. Make sure the load is pinched between the jaws – never cradle a load.
- For greater stability, knuckle the attachment to bring the load closer to the center of rotation (center of gravity) while lifting. Use extra caution during reaching to avoid tipping.

Place the Load Safely

- Do not move the attachment, or anything held in the jaws, over people, equipment or buildings. Place the load gently. Do not throw or drop the contents.
- Operate the controls smoothly and gradually. Jerky controls are hazardous and may cause damage to the carrier.
- Avoid fire hazards. Keep the area clean. Remove all flammable materials from the area during any welding or heating process. Have a fire extinguisher nearby and know how to use it.
- Never substitute pins or bolts. Use factory supplied pins. Replace all bolts with the same size and grade. Failure to do so may cause serious injury or death.
- Use your Genesis attachment only as directed in this manual. Do not use the attachment to lift and move other objects. Doing so may cause instability and tipping.

ATTACHMENT MARKINGS

Decals are necessary for safe operation and maintenance. To reorder, contact your Genesis dealer or call 715-395-5252.



TRANSPORT ROTATION LOCK

Your GDR may be equipped with one of two rotation lock systems.

Rotation (transport) locks are installed at the factory to allow the bracket to be shipped with the mounting pins facing upward. This is beneficial to the end user when removing the attachment from the truck and mounting it to the excavator.

Rotation locks MUST be removed before operating the attachment to prevent rotation system damage.

Tools equipped with transport lock pins:

Must be in **Stowed Position**
for normal operation

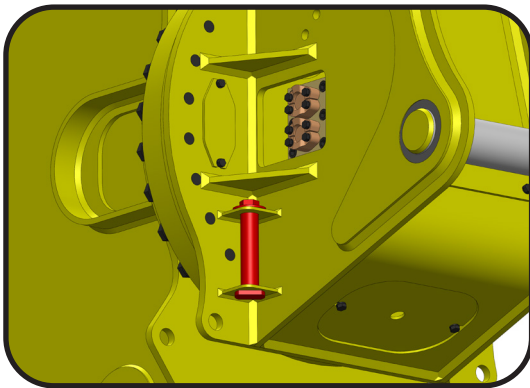

Locked Position
for transportation only

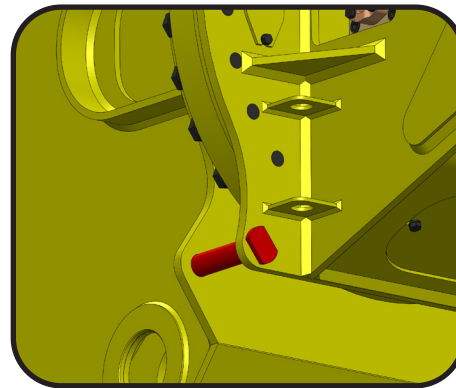

Tools equipped with slewing ring transport lock blocks:

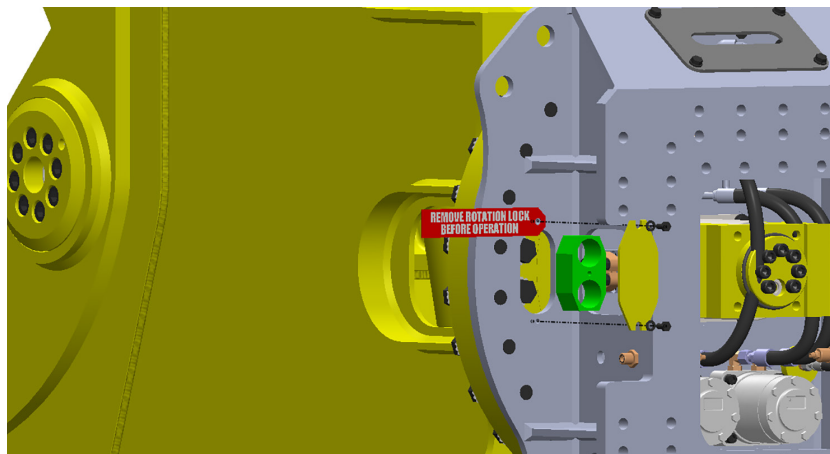

The rotation locks are located inside the small bolt covers for the slewing ring and marked with a red flag labeled "REMOVE ROTATION LOCK BEFORE OPERATION". The cover bolt can be threaded into the rotation lock for removal.

There are TWO locks in every attachment, one on either side of the bracket. In some cases, one of the port blocks may need to be removed to access the rotation lock. The rotation locks and red flags should be saved for use during future transportation.

ATTACHMENT INSTALLATION



Be sure hydraulic pressure is relieved before disconnecting hydraulic fittings. Remove necessary fittings SLOWLY.

Installation Procedure

The attachment is usually shipped in an upright position. Extreme care must be used when inverting the attachment for installation.

Follow the excavator OEM's removal and safety instructions to remove the bucket or other stick attachments.

Position the attachment upside down on flat, solid ground. Blocking may be required to raise the mounting bracket into proper position.

Track the excavator to the attachment with the jaws facing the operator. Lift the excavator stick over the attachment, carefully positioning the stick tip connection with the attachment mounting main pivot bore. Pin the excavator stick to the attachment.

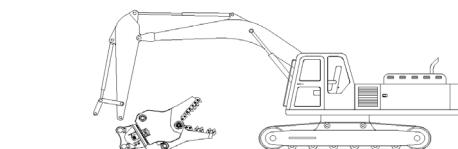

Slowly raise the boom to lift the attachment, allowing the cylinder pivot connection to come within range of the excavator cylinder stroke.

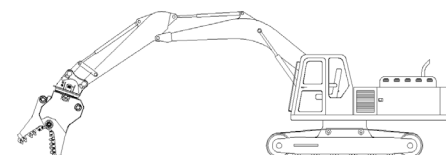

Extend the excavator cylinder until the power link bore lines up with the cylinder pivot connection. Pin the excavator cylinder to the attachment.

Crowd and extend the attachment, checking closely to make sure there is no interference between the bracket and hard lines. Also check for interference between the cylinder and boom/stick.

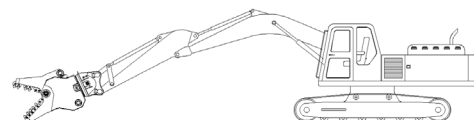

Install excavator hydraulic hoses, supply and return, from the stick tip to the attachment manifold blocks.

The stick and bucket circuits are oriented as to rod and bore sides of their respective cylinders. Be sure to connect rod-to-rod and bore-to-bore when connecting a circuit to the attachment. When these are reversed, extra pressure is needed to open the jaw, which pulls down the engine, de-strokes the pumps, increases jaw cycle time, creates high oil temperature and burns more fuel.

The attachment must be vertical before putting oil into it or an air lock in the regen valve may prevent the jaw from opening.

Note: Genesis' standard pin material is Induction Hardened Chrome (IHC), which is to be used for all direct pin 2nd and 3rd member mounting. To avoid risk of pin failure when using a pin grabbing coupler, the standard IHC pins must be replaced with a heat-treated pin material from Genesis.



Removing any connecting pin may be hazardous. To remove a connecting pin, position the attachment on the ground and properly support. Particles may fly when a pin is struck. Use a drift pin or mallet when striking pins. Keep all personnel at a safe distance.

ROTATOR INSTALLATION

Foot Switch Installation

Install the foot switch in the excavator and connect with electrical harness.

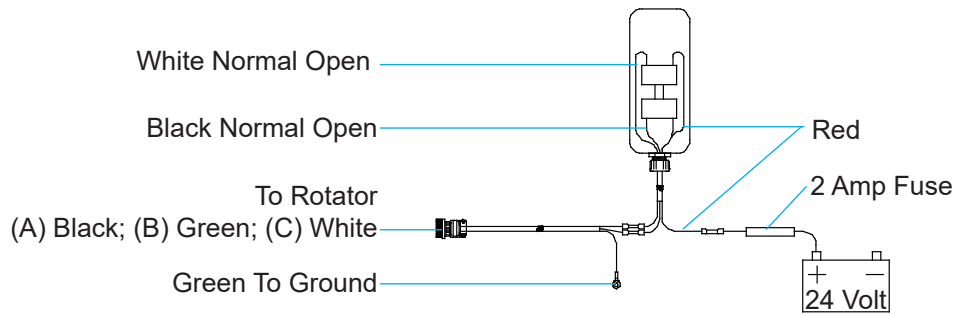

The rotator requires an additional hydraulic circuit. One of the several available options has been supplied with the attachment. These diagrams show the installation of the additional circuit. Refer to the Hydraulic/Rotation Maintenance section of this manual for valve descriptions, functions and settings.

ROTATOR INSTALLATION

Rotation Circuit - Gear Pump Type

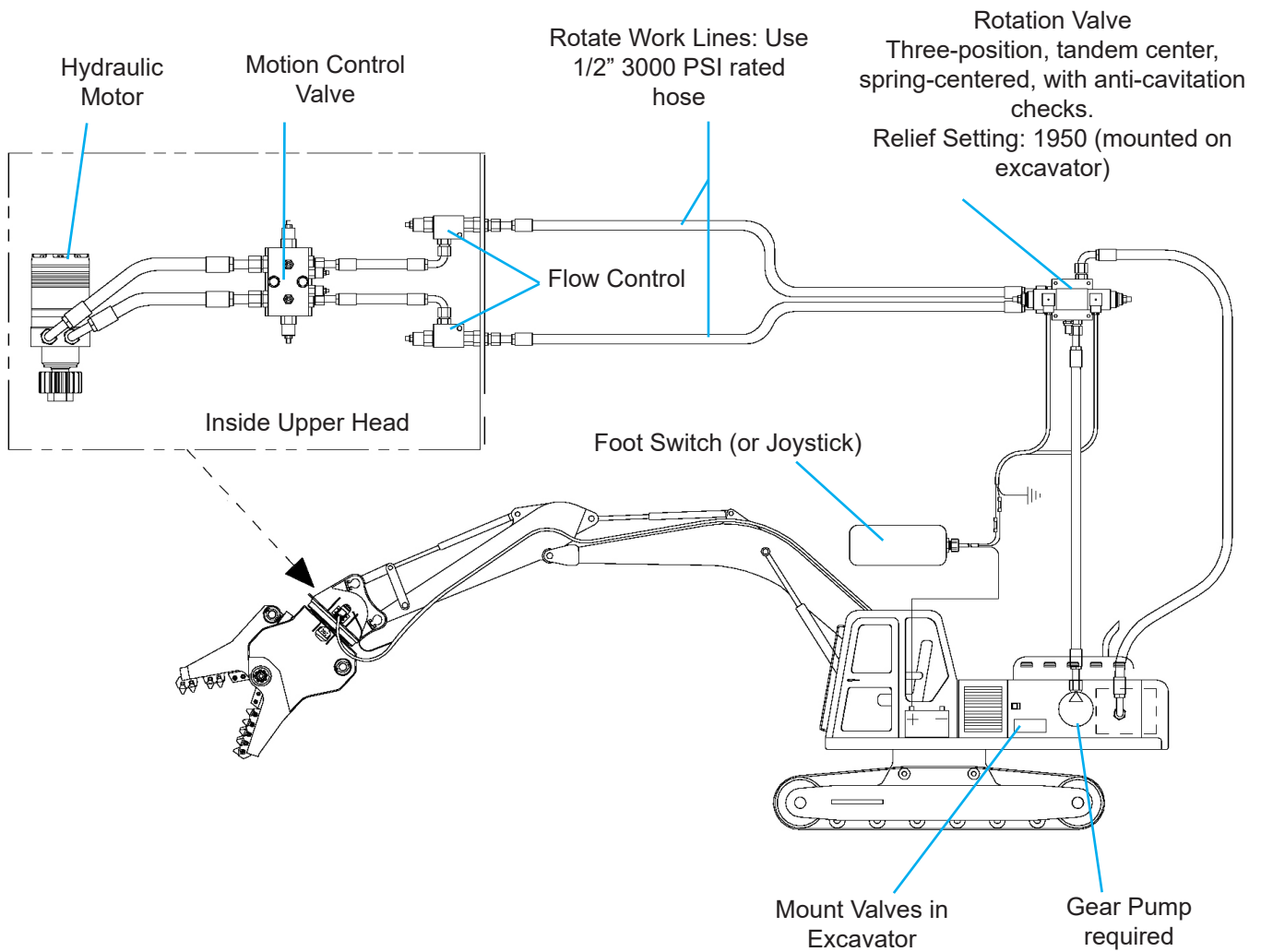

ROTATOR INSTALLATION

Rotation Circuit - Auxiliary Valve on Machine

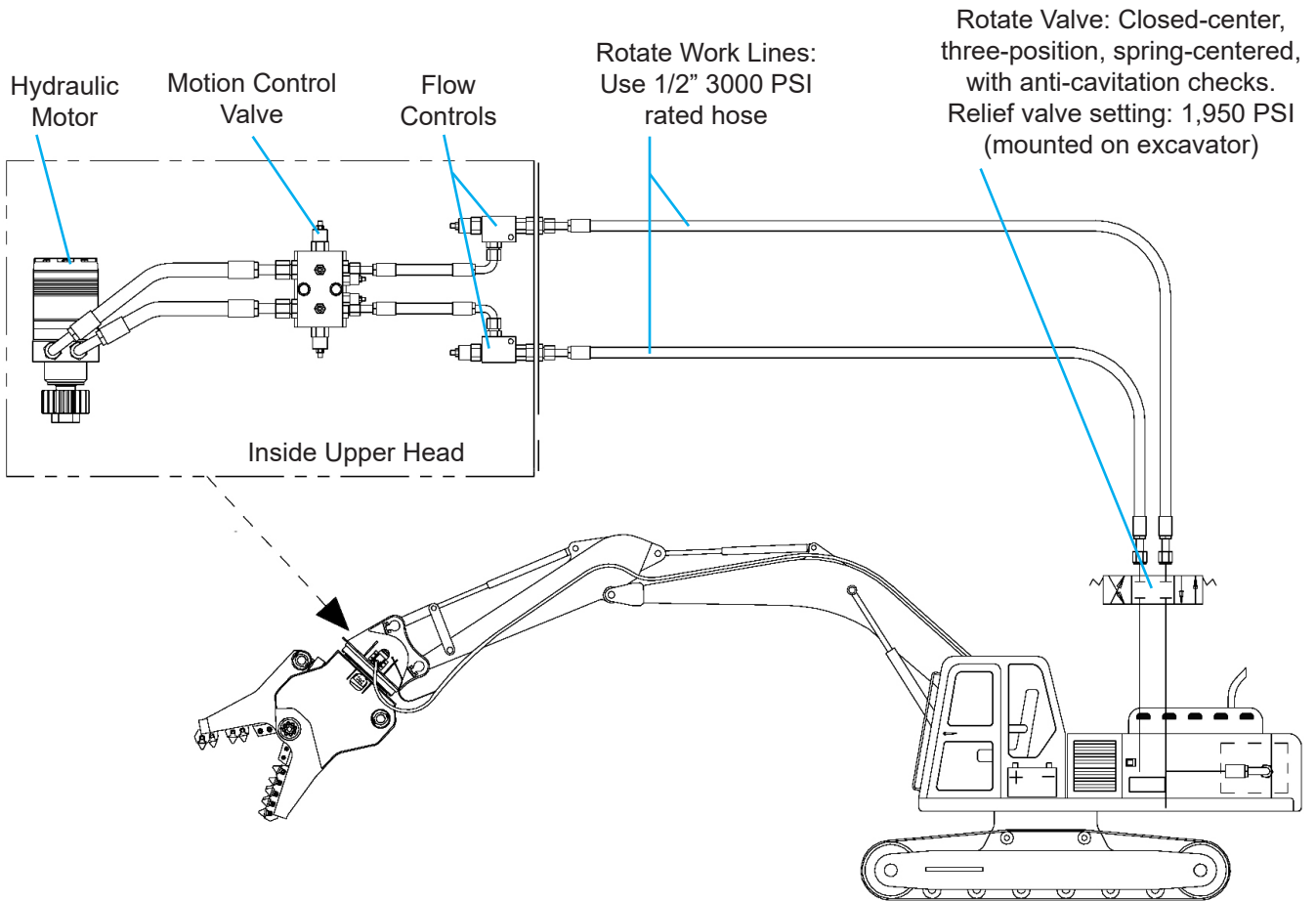

HYDRAULIC START-UP

Genesis attachments are designed to operate under full excavator pressure or up to 5500 PSI. Due to these high pressures, it is important that air is bled from the attachment cylinder after installation. Failure to follow these procedures could result in cylinder seal damage and/or excavator hydraulic system damage.

Start-up Procedure

- ✓ Check the excavator hydraulic tank for proper fluid level.
- ✓ Excavator oil should be warmed up before hooking up attachment lines in cold weather. If the oil is cold, air from the cylinder will be pushed into the oil tank, causing the oil to foam. This problem takes hours to correct and may cause pump cavitation.
- ✓ Follow the OEM procedures for starting and warming the excavator hydraulic system. Do not operate the attachment circuit during the warm-up period.
- ✓ After the excavator has reached normal operating temperature, set the engine to idle speed.
- ✓ The attachment must be vertical. Do not allow the tank to run low - have someone watch the oil gauge.
- ✓ Slowly fill the bore end of the attachment cylinder to partially close the jaws.

NOTICE

Do not fully extend or retract attachment cylinder with the first cycles.

Slowly fill the rod end of the attachment cylinder to open the jaws. Use partial strokes extending and retracting, slowly working to full strokes.

Stop and check the excavator hydraulic fluid level again to be sure there is still sufficient fluid. Service as required. The hydraulic fluid level should be checked with the attachment jaws open (cylinder retracted).

Cycle the attachment jaws five or six strokes before increasing to full operating pressure.

GENERAL OPERATION INSTRUCTIONS

Follow all rules and procedures outlined in the Operation Safety section of this manual.

Use the attachment only as intended, in approved applications, as set forth in this manual.

Do not allow attachment, exposed cylinder rod or hoses to come into contact with any obstacles, buildings or the excavator.

The attachment is not intended to crush or break objects or structures by swinging or dropping the attachment.

Start-up

During initial operation and any time jaw maintenance has been performed, process thin and lighter material first to work-harden wear areas, developing a harder, more durable edge.

NOTICE

When operating in temperatures below freezing, it is also important to process light materials first. This allows the attachment's structural material to warm up, preventing thermal cracking.

Efficient and Productive Operation

Operators should become accustomed to performing work in the most proficient manner possible.

Material processing areas should be as close as safely possible to the location for loading materials for transportation. Less time spent processing, loading and transporting materials greatly affects operational costs and productivity and dramatically reduces man hours, fuel costs and wear on equipment.

Operators should develop the habit of assessing materials to be processed and visualizing a starting and finishing point to avoid unnecessary cutting/crushing. Excessive moving, positioning and handling cost time and money. Bringing the jaws to full open, when only partial jaw open is needed, wastes time and fuel, slows other excavator functions as well as causes needless wear to hydraulic components, hoses and o-rings. More efficient processing will extend the life of the attachment.

COMMON OPERATIONAL CONCERNS

When working in a situation where debris may fall from above, rotate the attachment 180° so the stationary jaw is on top. This will prevent debris from falling into the body while the upper jaw is closed or closing.



CAUTION

Keep debris from falling into the body of the attachment to prevent hydraulic component damage.

Cutting Larger Materials

When processing larger materials the jaw stalls just before cutting/crushing.

Reposition the attachment so the material is as close to the throat as possible. Without pushing down on the material with excavator force, rapidly close the jaw on the material. Using the speed of regeneration can improve performance when processing larger materials.

Chatter While Cutting

If the attachment starts to chatter while cutting, back out of the cut and reposition at a different spot.

Chattering is an indication that material is jamming between the upper and lower cutting blades. This indicates that blade maintenance needs to be performed immediately. Worn blades and improper blade gaps are usually the cause.

Most jamming conditions can be prevented if the operator pays attention to the sound and vibration that is associated with a jam. Remember that because of the rod-to-bore ratios of displacement on the attachment's hydraulic cylinder piston, the attachment has half the force on jaw open compared to jaw close. So if the attachment is jamming while closing, it won't have enough retract force to open.

MAINTENANCE SAFETY

Only trained and authorized persons should perform maintenance on the attachment. To be qualified, you must understand the instructions in this manual, have training, and know the safety rules and regulations of the job site.

Do not alter the physical, mechanical or hydraulic operation of the attachment. Doing so may cause a dangerous situation for yourself and those around you and will void the warranty.

Do not attempt repairs you do not understand. If any questions arise regarding a safety or maintenance procedure, contact Genesis or your Genesis dealer.

Read this entire manual. All personnel must understand the maintenance and safety procedures.

Use factory authorized parts. The use of unauthorized parts may compromise safety, performance and durability of the attachment and may void the warranty.

Follow the daily checklist and maintenance schedules in this manual. Extreme conditions may dictate shorter maintenance intervals.

Do not exceed bolt torque specifications. See the Genesis Fastener Manual.

Do not weld on structural components without consulting Genesis. Doing so may cause structural failure and void the warranty.

Do not work on the attachment before ensuring it will not move. Completely lower the boom to the ground or a rest position and relieve hydraulic pressure.

Never operate poorly maintained equipment. When maintenance is required, repair or replace parts immediately.

Do not operate under unsafe conditions. If an unsafe condition arises during operation, immediately shut down the equipment and report the situation to the proper authority.

MAINTENANCE SAFETY

Do not work on any hydraulic lines or components while they are pressurized. Escaping hydraulic fluid can penetrate the skin, causing serious injury or death. Relieve pressure before performing maintenance. Keep hands and body parts away from pin holes and nozzles, which eject fluids under high pressure. Use a piece of cardboard to search for leaks.



If fluid is injected into the skin, seek medical assistance immediately from a doctor familiar with this type of injury.

NOTICE

See "Use Care with Hydraulic Fluid Pressure", page 13

Hydraulic oil becomes hot during operation. Do not let hydraulic oil or components contact skin, as it could cause severe burns. Allow hydraulic components to cool before working on them. Use protective clothing and safety equipment.



Remove paint before welding or heating. Hazardous fumes/dust can be generated when paint is heated by welding, soldering or using a torch. Do all work outside or in a well ventilated area and dispose of paint and solvent properly.

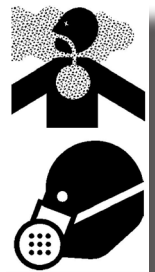

When sanding or grinding paint, avoid breathing the dust. Wear an approved respirator. If you use solvent or paint stripper, remove stripper with soap and water before welding. Remove solvent or paint stripper containers and other flammable materials from area. Allow fumes to disperse at least 15 minutes before welding or heating.

Avoid fire hazards. Keep the area clean. Remove all flammable materials from the area during any welding or heating process. Have a fire extinguisher nearby and know how to use it.



Never substitute pins or bolts. Use factory supplied pins. Replace all bolts with the same size and grade. Failure to do so may cause serious injury or death.

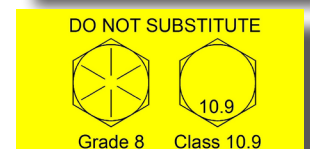

MAINTENANCE SCHEDULE

Performing scheduled maintenance will promote safe, reliable operation of your attachment. Use maintenance procedures described in this manual. If you are not able to safely and competently perform these procedures, have a Genesis dealer perform them.

NOTICE

Extreme operating conditions may require shortened maintenance intervals.

Four-Hour Checklist

Inspect:

- Bolts - check for loose bolts, replace if damaged
- Fittings and hoses for damage or leaks
- Bracket pivot for wear and pin retainers
- Cylinder pivot for wear and pin retainers
- Entire attachment for cracks (visual check)

Grease:

- Attachment cylinder butt
- Attachment cylinder rod
- Main shaft/pivot, both sides

Eight-Hour Checklist

Perform four-hour checklist plus the following:

Grease:

- Bracket pivot
- Bracket cylinder
- Rotation bearing (four locations)
- Rotation bearing gear teeth

Jaws, blades and teeth:

- Check blade tolerance
- Check blade edge radius
- Check for loose or excessively worn teeth
- Check for loose or damaged bolts, retorquing loose bolts when cool
- Build-up and hard-surface as required

See Blade Maintenance section in this manual regarding maximum tolerance and radius. See Jaw Maintenance section in this manual for build-up and hard-surfacing instructions.

Long-term Maintenance

- Check all bolts, including slewing ring bolts, after the initial 80 hours of operation
- Replace slewing ring bolts every 2000 hours
- Replace regeneration valve components every 2 years or 4000 hours
- Reseal cylinder every 4000 hours
- Reseal swivel every 4000 hours

LUBRICATION POINTS



DANGER

Shut off excavator and disable hydraulics per OEM instructions before greasing.

For normal conditions above 32°F (0°C), use a lithium-based, premium grade 2 extreme-pressure grease. For temperatures below 32°F, use a grade 0 grease.

Do not use grease containing Molybdenum (Moly).

Genesis GLG-2® anti-wear, extreme-pressure lithium grease, PN 6302601, is recommended for all temperature conditions.

Grease all fittings every four to eight hours of operation (see maintenance schedule). Grease until extrusion is visible.

After greasing the rotation bearing, rotate the attachment through two full rotations. The cylinder and pivot should be greased at four hours and eight hours of operation, while the attachment is warm. The bracket and rotation should be greased at the end of an eight-hour shift.

Grease locations:

1. Bracket pivot
2. Bracket cylinder
3. Attachment cylinder rod
4. Attachment cylinder butt
5. Main shaft/pivot (both sides)
6. Rotation bearing (four locations)
7. Rotation bearing gear teeth



TOOTH AND BLADE MAINTENANCE

Blade, tooth, pocket and blade seat maintenance greatly affects performance. To maximize performance and optimize the life of replaceable parts, follow all instructions for checks, adjustments and maintenance described in this section, at the intervals listed in the maintenance schedule in this manual.

Before performing maintenance, read, fully understand and follow these safety rules.

Wear personal safety equipment including gloves, safety glasses, safety boots and proper clothing.

Safe blade maintenance requires two people - one to steady the blade while the other loosens the bolts.

Blades are heavy and may fall out of the blade seat if not adequately supported. Bystanders must stand clear.

Never strike a blade with a hardened steel tool. The blade may fragment, creating sharp flying debris.

Pulverizing Teeth

As teeth become worn, they need to be rotated, built-up or replaced. To help customers determine and monitor how far processor teeth have worn from their original shape, Genesis has tooth build-up templates available.

Each template is sized and formed to that tooth's original shape and features three lines that indicate wear level. Simply place the template over the tooth to determine the amount of wear and build-up required or if replacement is needed.



Line 1	½ inch wear - schedule maintenance to flip or rotate in jaw
Line 2	1 inch wear - flip, rotate in jaw or build up
Line 3	1½ inch wear - replace, if all points are worn on flippable teeth

Contact your local Genesis dealer or the Genesis Parts Department to order.

Model	Part Number	Template
150 & 200	9100899	
150 & 200	9102587	

Model	Part Number	Template
300 & 400	9102826	
300 & 400	9102586	

TOOTH AND BLADE MAINTENANCE

At the end of each shift, check the condition of pulverizing teeth. Replace any broken bolts, and retorque loose bolts when cool.

Replace teeth when tip becomes severely rounded or flat. A more pointed tooth will process concrete more efficiently.

Pulverizing teeth may be welded to tooth holder if desired.

Tooth holders should be replaced when the tooth fit is sloppy. A loose tooth fit will put undue stress on the bolt. Tooth may be welded in place to extend the life of a worn tooth holder.

Cutting Blades

Proper maintenance of the cutting blades is required for optimal performance. Blade rotation extends blade life and improves cutting performance. Shimming to maintain blade tolerances helps prevent jamming.

Inspect blades every eight hours of operation. Replace any broken bolts, and retorque loose bolts when cool. Grind away dents or mushrooming of blade edges at the end of each day to prevent upper jaw deflection, excessive blade wear and undue stress to jaws.

Rotate blades to use all four cutting edges. Always use Genesis-approved blades. Blades that do not meet Genesis specifications can cause major problems, and using them may void the warranty.

Blade Removal

Loosen the bolts on one blade at a time, enough to loosen the blades. Carefully remove bolts and blades.

Blade Rotation

Rotate blades when the cutting edges are worn to a 1/8" (3mm) radius.

Recommended rotation intervals are approximately 40-80 hours, depending on the material being processed. Thin materials may require shorter rotation intervals. Blades must be replaced when all four edges are worn to 1/8" (3mm) radius.

The following chart may be copied and used to track blade rotation.

40 - 80 Hours	Date	Hour Meter	Performed By
Installed			
Rotation 1			
Rotation 2			
Rotation 3			

TOOTH AND BLADE MAINTENANCE

Blade Gap

After each blade rotation, shim lower blades to keep the gap within a range of 0.005" to 0.015". Do not shim the upper blades. Use only Genesis shim kits.

Blade Gap Measuring Procedure

Slowly close jaws until blades begin to bypass. Stop the jaw and check the gap with a feeler gauge.

Cycle the jaws slowly and continue checking the gap at several points along the entire length of the blades.

Note: The gap will be consistent along the entire length of the blades if they have been rotated and shimmed correctly.

If blade gap exceeds the 0.015", shim lower blades. Blades must be replaced when shims exceed 0.060".

Shimming Procedure

Loosen blade bolts.

Install shims between blade and blade seat as needed to bring into tolerance.

Torque bolts to spec and recheck tolerances.

Do not use more than 0.060" of shims.

GENERAL WELDING GUIDELINES

Build-up and hard-surfacing are welding procedures that protect the parent material of the jaws and keep the tool in good condition. Build-up is the welding procedure that restores the jaws to their original shape. Building up the jaws helps protect the blades and increases the life of the attachment. Hard-surfacing is the welding material added over the parent material (or build-up material) to create a wear-resistant surface.

Welding should not be performed until the jaws are work-hardened. Work-hardening can take up to 80 hours.

Welding Ground Clamp

Disconnect all battery ground cables or shut off master battery switch, if equipped.

Failure to do so may cause excavator electrical problems, including permanent damage to onboard computer systems.

Connect ground clamp as close as possible to the area being welded without allowing current to pass through the pivot group, cylinder pin, cylinder, swivel, motor, gearbox or slewing ring.

If you are welding on the lower jaw, connect weld clamp to the lower. If you are welding on the upper jaw, connect to the upper but not to the cylinder clevis. If needed, weld a piece of steel to the area for the grounding clamp and cut the piece off when welding is completed.

Welding Rules

Before you begin:

- Remove adjacent blades, as preheating and welding may cause damage.
- Do not remove teeth, as weld spatter on tooth holder would cause fitment problems.
- Wearing an approved respirator, grind the area to clean it and remove all existing hard-surfacing.
- Preheat area to 350° F (177° C). Maintain this temperature throughout the procedure. Do not exceed 450° F interpass temperature.

During welding:

- Always grind and weld with the grain of the material.
- Peen each weld pass to relieve stress and harden the welds.
- Do not undercut the ends of the welds.

After welding maintenance is complete:

- Cover the area with a heat blanket and allow it to cool slowly, approximately eight hours.
- Do not put the attachment into operation until the welds have been allowed to cool.

BUILD-UP AND HARD-SURFACING

Procedure:

Follow the General Welding Guidelines and Rules.

Determine the area to build up, using a straight-edge or square. Do not allow jaws to wear to more than a 3/4" radius on edges of tool.

Build up the jaw to slightly higher than the original parent material profile with E7018. Apply single passes in each line with the grain of the steel, peening after each pass.

See drawings for grain, as indicated by arrows. (Red lines indicate hard-surfacing pattern.)

After build-up is complete, grind material to be flush with the flat surfaces of the tool or, if building up a blade seat, grind material to be flush with a new blade.

Hard-Surfacing Patterns

Where parallel lines are shown, apply single passes approximately 1" apart. Cover exposed faces with a crosshatch pattern with stringer beads at 45° angles to form 1" squares.

Hard-surfacing patterns are indicated by red lines in the drawings. Crosshatch may be used in place of straight stringers on any flat areas of the jaws and on the outside of the upper jaw.

Do not crosshatch the curved areas of the jaws near the pivot. Use only straight stringers on these areas.

Follow hard-surfacing instructions on the following page.

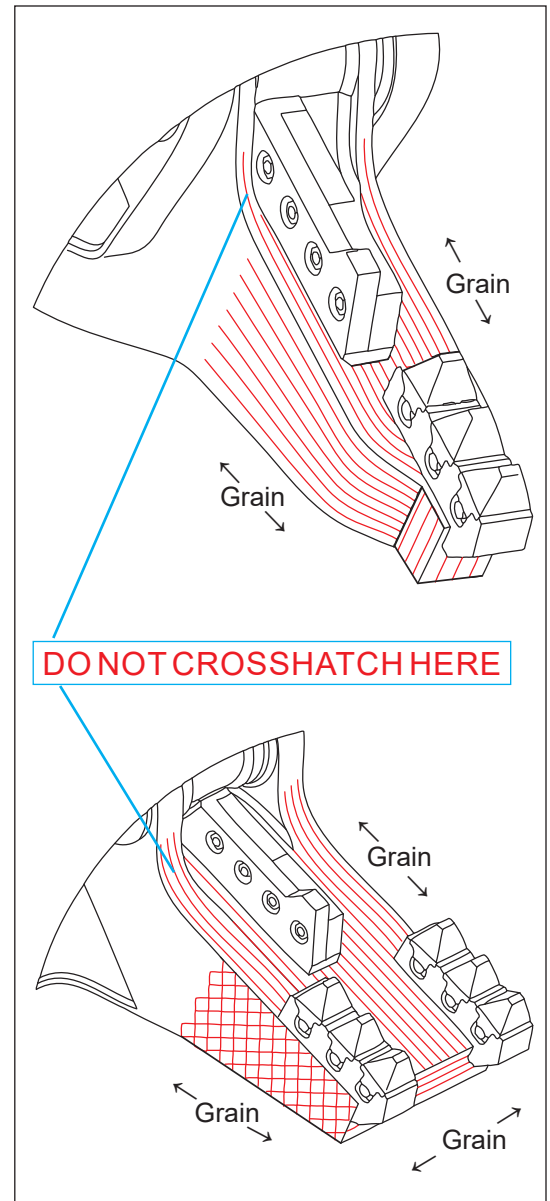

HARD-SURFACING

Do not apply hard-surfacing directly to the parent material as this could cause toe cracking, and the hard-surfacing will break away.

Procedure:

Follow the General Welding Guidelines and Rules.

Apply a single pass stringer bead pattern, with the grain, using E7018 electrode. Peen each pass.

Do not apply a stringer directly on the edge. Start the first pass 1/4" from the edge.

Stagger the ends of the stringer welds so they do not end in a straight line.

Cap each stringer bead with one pass of GenWire or GenRod to hard-surface. Do not apply more than two layers of hard-surfacing. Peen each pass.

Grind the ends of all stringer welds, with the grain to taper 1" to 1-1/2" (25 - 38 mm) to the parent material.

See the previous page for hard-surfacing illustrations and instructions specific to each area of the jaws.

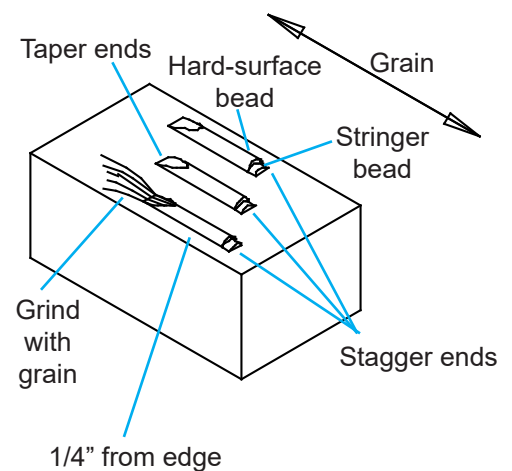

HYDRAULIC/ROTATION MAINTENANCE

Hydraulic Requirements

Operating the attachment below the recommended flow and/or pressure range will adversely affect performance and may damage the rotate motor.

Operating the attachment above the recommended flow and/or pressure range may damage the attachment and its hydraulic components.

Model	Flow	Pressure
150	25-40 GPM (95-151 LPM)	4500-5500 PSI
200	40-60 GPM (151-227 LPM)	
300	60-100 GPM (227-379 LPM)	
400	80-100 GPM (303-379 LPM)	

Rotation Valve Settings

When checking the crossover relief valve settings, put pressure gauges on both diagnostic ports. Stall attachment rotation in clockwise direction. Increase supply pressure until pressure at gauge on crossover stops rising. This is the crossover relief setting. Increase supply pressure to achieve approved crossover relief value. Repeat procedure in counter-clockwise direction. Then lower supply pressure back to approved value.

Model	Flow	Supply Pressure	Crossover Relief
150	3-5 GPM (11-19 LPM)	1500 - 1700 PSI (103 - 117 Bar)	2200 PSI (152 Bar)
200			
300			
400	7-11 GPM (26-42 LPM)	1900 - 2100 PSI (131 - 145 Bar)	

HYDRAULIC/ROTATION MAINTENANCE

GenFlow Regeneration Valve

A regeneration valve features a GenFlow adjustment cartridge to control the timing of the shift between speed and power modes. When the cartridge is properly set, the processor closes rapidly until it begins to cut. The valve shifts, slowing jaw close and increasing power. You may hear a squeal or hiss as this happens. The valve shifts back into speed mode after the cut is complete.

The cartridge is factory-set, turned out approximately five turns. This setting is appropriate for most applications. However, the cartridge may be custom-set if necessary.



View Adjustment Cartridge

Regeneration Valve Adjustment

Regeneration valve adjustment is a two-person job. The ground crew must be in full view of the operator at all times and must stand clear of the processor jaws when cycling.

Check the cycle time when the hydraulic fluid is warmed up, timing from full open to full closed and back to full open.

To shift into power mode sooner, turn adjustment cartridge out (counter-clockwise). To shift into power mode later, turn in (clockwise).

Loosen the lock nut with a 9/16" socket.

Turn cartridge 180° (half-turn, 145 PSI) with a 5/16" allen-head socket.

Tighten lock nut.

Check the cycle time.

Repeat until the preferred balance of speed and power is met. Final adjustment may require less than a half-turn.

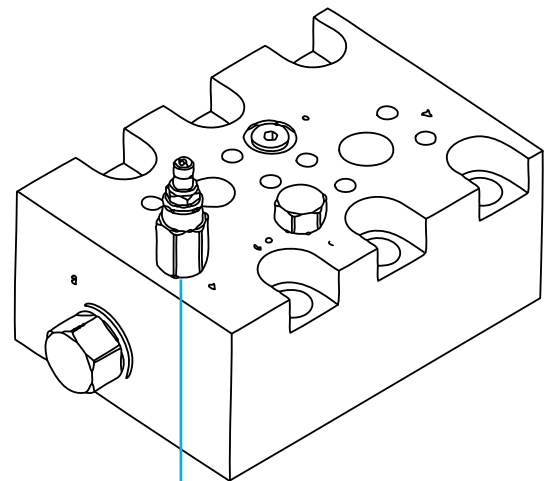

Adjustment Cartridge



Shut off the excavator and disable the hydraulics per OEM instructions before adjusting the cartridge.

GENFLOW REGENERATION VALVE - HOW IT WORKS

Jaw Close in Regeneration: Oil that would normally leave the rod end of the cylinder and return to the tank is diverted to the bore end of the cylinder, increasing flow by approximately 50 percent and speeding up jaw close. In this mode, oil pressure on both rod and bore sides of the cylinder piston are basically equal and, although this speeds up the cylinder extend speed, it results in pressurized fluid on the rod side. If left in this mode, cylinder power is greatly reduced.

Jaw Close in Power Mode: To provide full power, when the upper jaw hits the material, the pressure rises. Once pressure exceeds the adjustment cartridge settings, it then shifts the rod oil back to the excavator hydraulic tank instead of the bore end of the cylinder. Pressure in the rod also drops, allowing full force from the bore pressure to be applied to the upper jaw for full cutting.

Jaw Open: Oil goes to the rod end of the cylinder, and bore oil goes back to the tank.

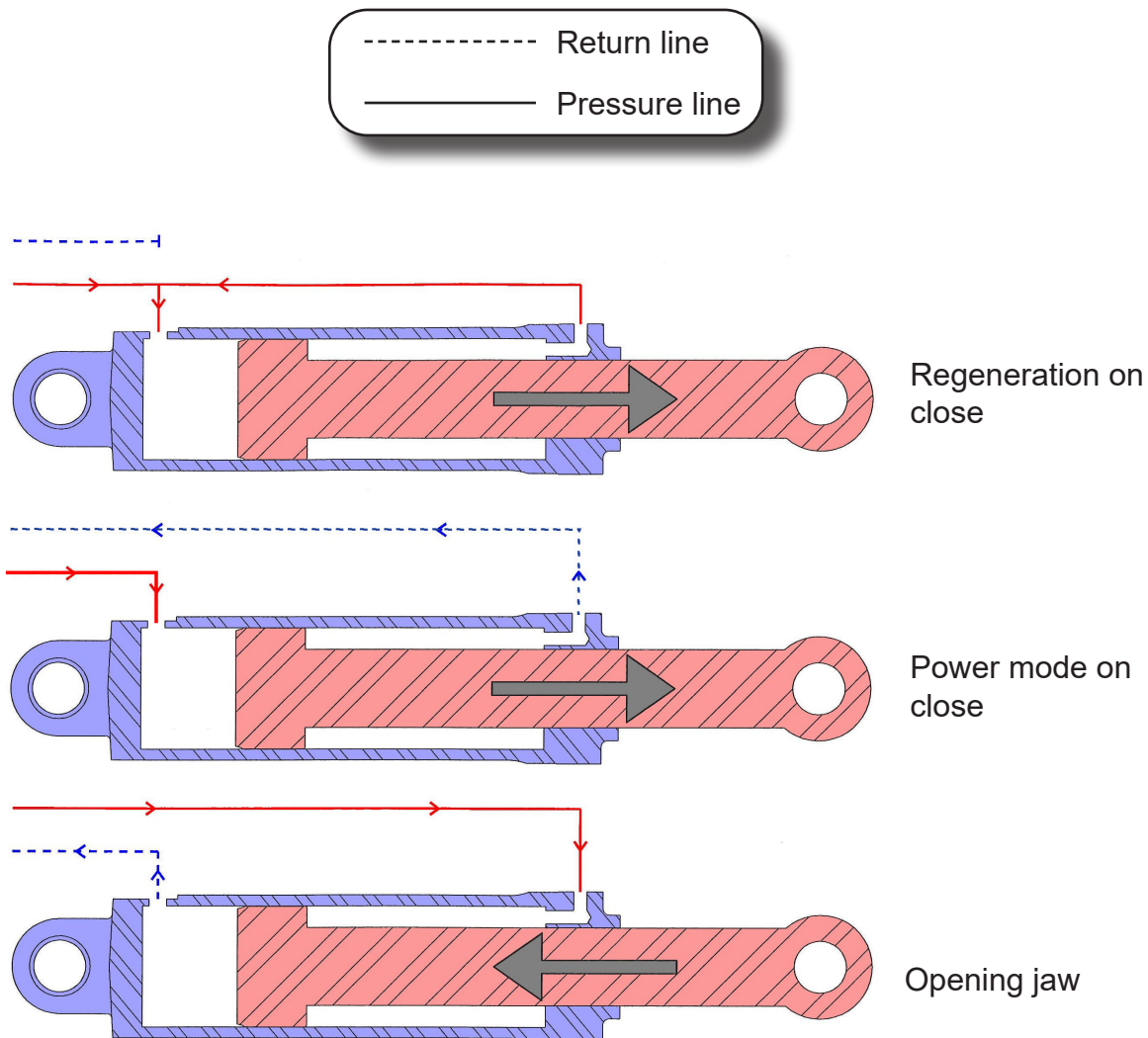

GENFLOW REGENERATION VALVE

GDR 150/200/300

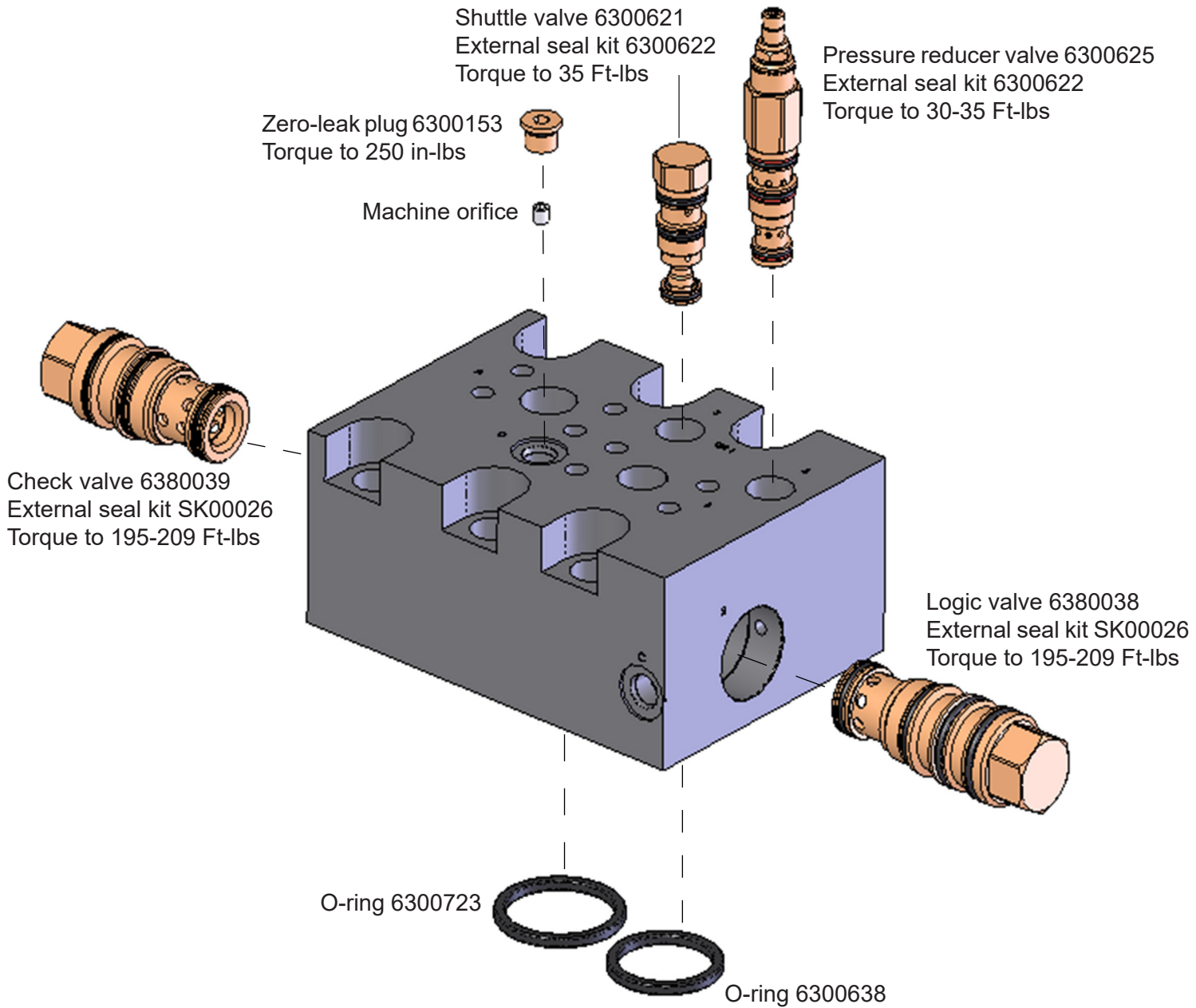

GENFLOW REGENERATION VALVE

GDR 400

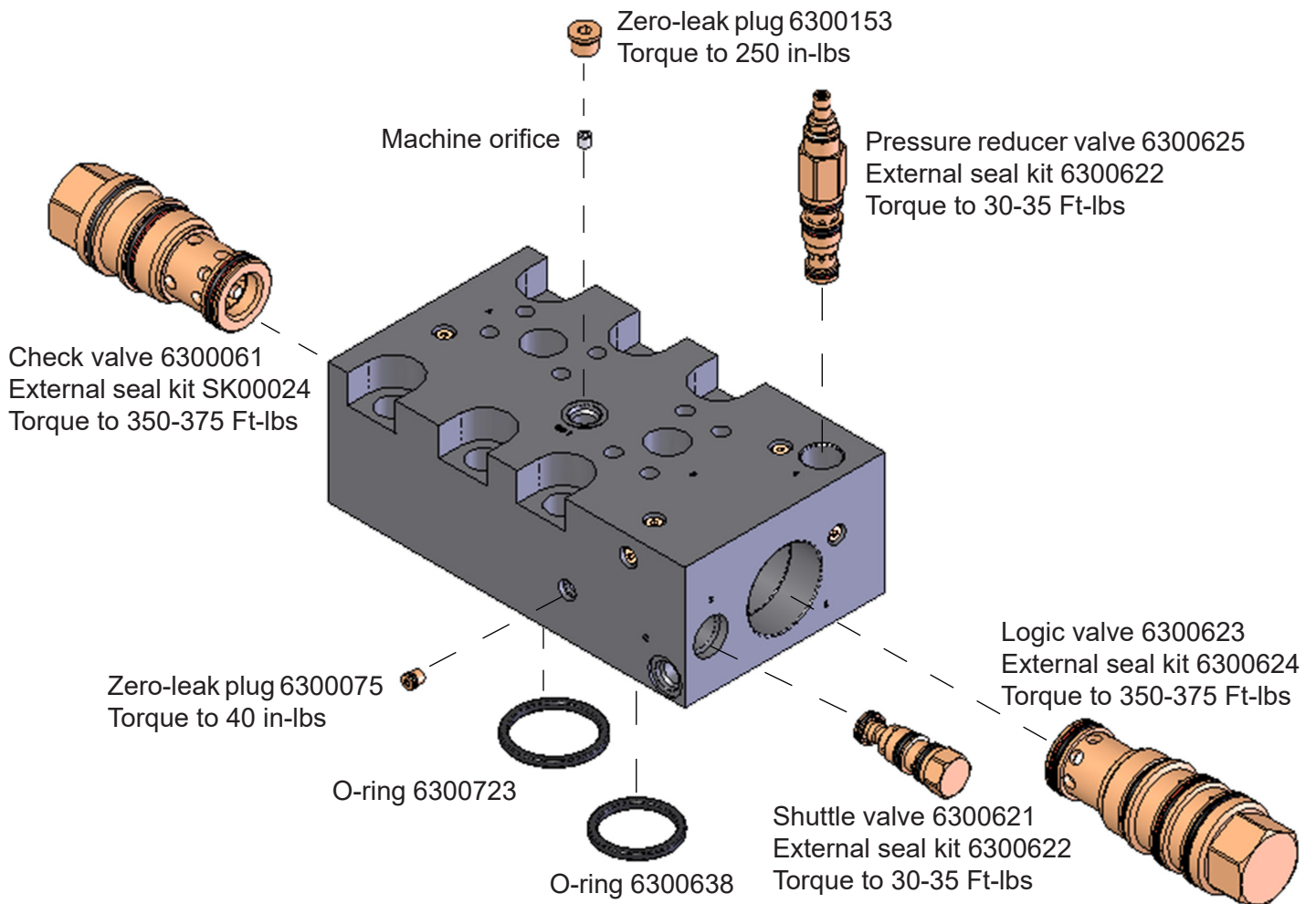

SLEWING RING MAINTENANCE

Visually check slewing ring (rotation bearing) bolts every eight hours of operation. Do not reuse or re-torque these bolts. Loose or broken bolts, along with the bolts on either side, must be immediately replaced.

The bolts that secure the slewing ring are critical for safe attachment operation. Improper torque may cause the bolts to fail and the attachment to break free, which may result in serious personal injury and equipment damage. Improper torque will also cause uneven slewing ring wear.

Rotating components must be greased daily. Grease fittings are located on the outside of the slewing ring and on the inside of the rotating head assembly. Grease locations are marked with decals.

Grease each fitting and then rotate the attachment two full rotations.

For normal conditions above 32°F (0°C), use a lithium-based, premium grade 2 extreme-pressure grease. For temperatures below 32°F, use a grade 0 grease. **Do not use grease containing Molybdenum (Moly).**



Genesis GLG-2[®] anti-wear, extreme-pressure lithium grease, PN 6302601, is recommended for all temperature conditions.



Stand clear when the attachment is being rotated. Always stay in clear view of the operator.

ROTATION CIRCUIT

To meet diverse customer needs, Genesis offers several rotation valve options. They vary in mounting, function, factory-supplied and customer-supplied parts, and operating advantages. For information on each type of rotation circuit, see the following pages.

Valves are factory-set and should not need adjustment. If you believe adjustment is necessary, contact the Genesis Service Department.

Note: Genesis does not recommend using the excavator bucket circuit for rotation circuit directional control as it will lead to motor failures.

All rotation circuits use the same procedure for setting flow:

- Rotate attachment, timing one complete revolution.
- Adjust corresponding flow control until revolution time is 14-16 seconds.
- Repeat in opposite direction.

ROTATION CIRCUIT

Rotation with Motion Control Valve

Setting the crossover reliefs:

1. Increase supply pressure to the rotation valve to 2500 PSI.
2. Install pressure gauges on relief test ports.
3. Plug hoses at motor or secure the attachment from rotating.
4. Pressurize the valve to rotate.
5. Adjust the corresponding relief valve to the pressure specified in the rotation valve settings table.
6. Repeat for the other direction.
7. Reduce supply pressure to the pressure-reducer valve setting specified in the rotation valve settings table.

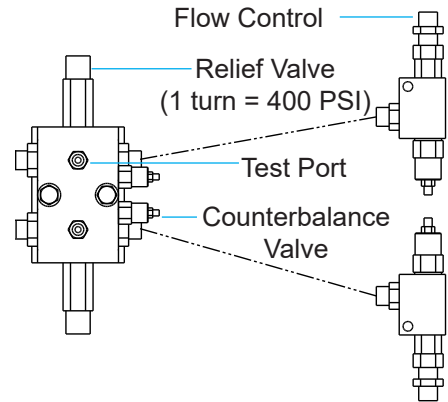

If you cannot reach the pressure specified in the rotation valve settings table, adjust the counterbalance valves using the following procedure:

- Turn crossover relief valve adjustment screws clockwise to their maximum setting, recording the number of turns so they can later be returned to their original setting.
-
- Adjust the counterbalance valves by turning the adjustment screws counter-clockwise until the correct setting of 2500 PSI is reached.
-
- Repeat steps 6 and 7 for setting the crossover reliefs.

If you have questions regarding setting your rotation circuit, please contact the Genesis Service Department.

ROTATION CIRCUIT

Flow Divider Rotation

Setting the crossover reliefs:

1. Install a pressure gauge on the unloading valve, unplug the wires to the directional valve and energize the valve on the unloading valve.
2. Adjust the unloading valve to 2500 PSI.
3. Reconnect the wires to the directional valve.
4. Plug hoses at motor or secure the attachment from rotating.
5. Press the switch to rotate left or right.
6. Adjust the corresponding relief valve to the pressure specified in the rotation valve settings table.
7. Repeat for the other direction.
8. Set the unloading valve before operating.

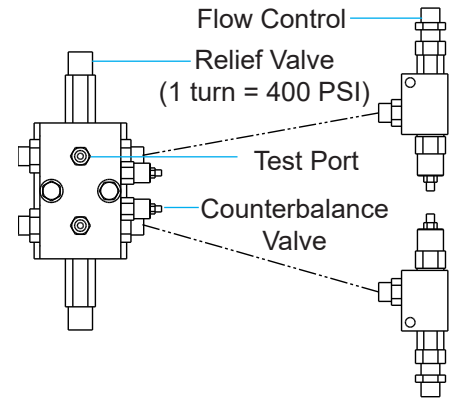

Setting the counterbalance valve, if equipped with a motion control valve: follow the procedure on the previous page.

Setting the unloading valve:

- Install a pressure gauge on the unloading valve, unplug the wires to the directional valve and press the switch to rotate left or right.
- Adjust the unloading valve to the pressure specified in the rotation valve settings table.
- Plug the wires back into the directional valve.

ROTATION CIRCUIT

Gear Pump Rotation

Setting the crossover reliefs:

1. Increase supply pressure to the rotation valve to 2500 PSI.
2. Install pressure gauges on relief test ports.
3. Plug hoses at motor or secure the attachment from rotating.
4. Pressurize the valve to rotate.
5. Adjust the corresponding relief valve to the pressure specified in the rotation valve settings table.
6. Repeat for the other direction.
7. Reduce supply pressure to the pressure-reducer valve setting specified on the table for rotation valve settings.

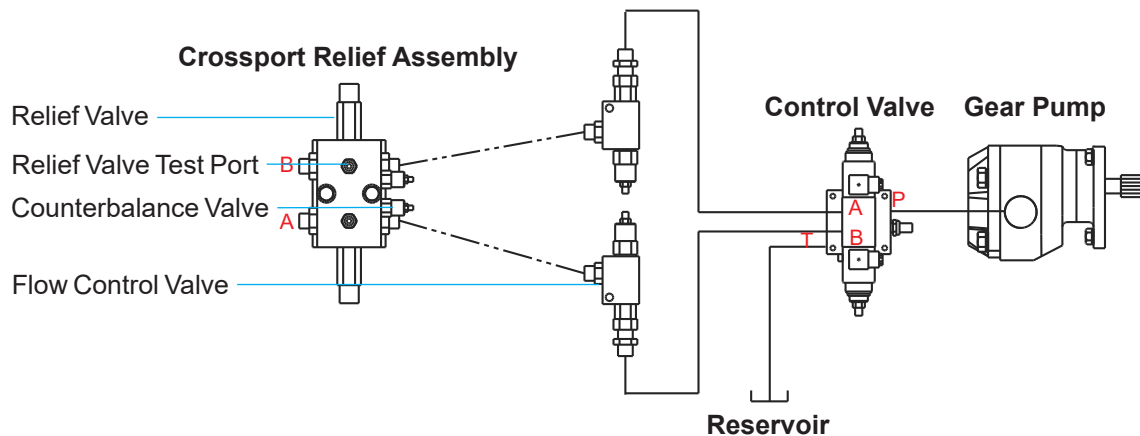

GDR 400 MOTOR REPLACEMENT

Prior to replacing or removing the GDR 400 motors, key steps must be followed to ensure the motor backlash to the slewing ring is set correctly.

- Each motor has a specific spacer ring that must stay in the correct location.
- A timing mark must be made on the motor spacer to mark for proper alignment and location inside the sub-head.
- After this is complete, the motor may be removed. If replacing the motor, the spacer ring must be removed from the old motor and placed on the new one.
- Install the new motor ensuring that the timing mark on the spacer ring is aligned prior to torquing the motor bolts.

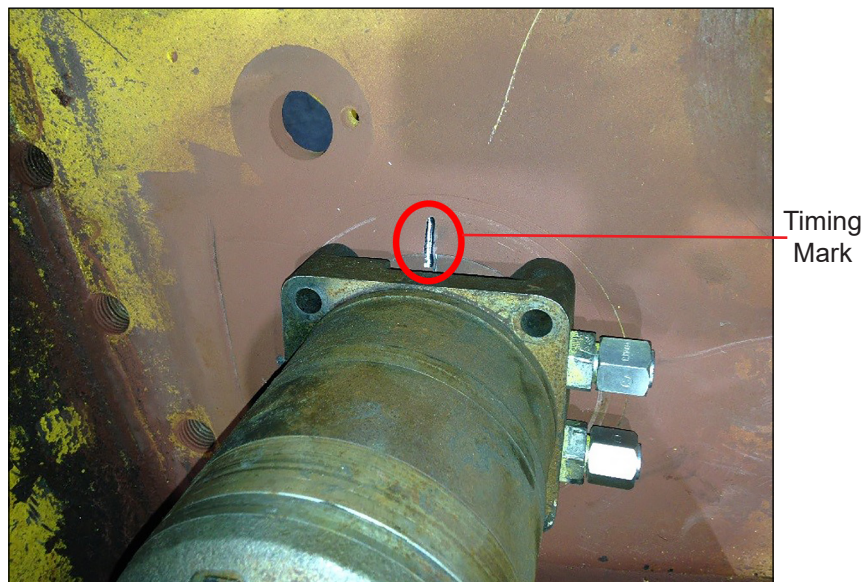
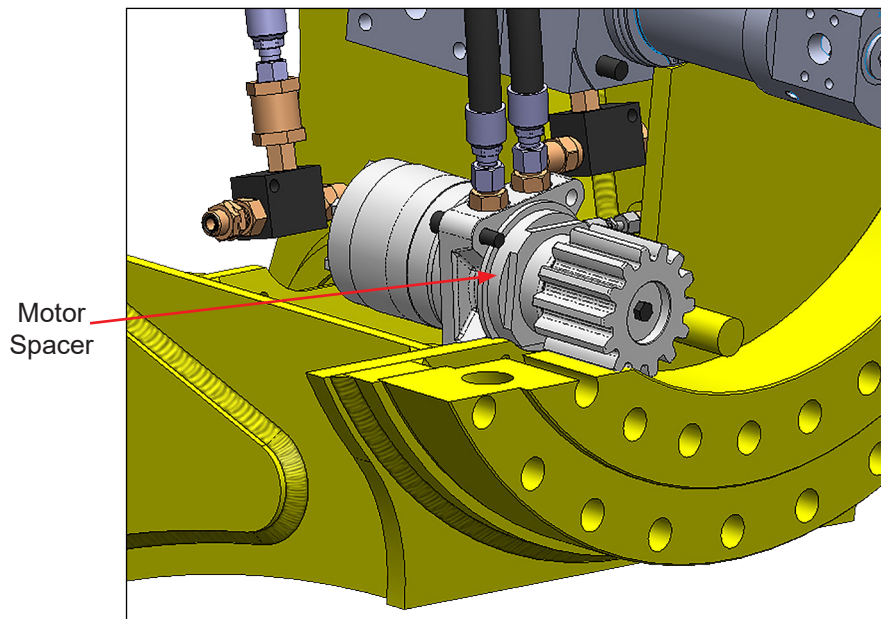

TROUBLE-SHOOTING GUIDE

Symptom	Possible Causes/Solutions
Low power	Check pressures and back pressure at port blocks on attachment
	Isolate attachment from excavator and check excavator pressures at boom tip or arm
	Attachment may be partially stuck in regen mode; follow adjustment procedure
	If speed is good with low power, internal seals on logix cartridge may need to be replaced
	Possible cylinder, swivel or regen bypass (contact Genesis Service Department for procedures)
Slow jaw open with low power	Pilot check valves in regen valve may have worn or damaged seals
Slow jaw close	Check flows from excavator
	Check regen relief valve adjustment if attachment is new
	Adjustment cartridge may have damaged seals or may be stuck open
	Regen check valve or logix valve may have damaged seals or may be stuck open
Good speed but attachment stalls before cutting	Regen adjustment cartridge is turned in too far
Jaw drifts closed or can be pushed closed	Bleed down orifice may be plugged
	Pilot check valves may be leaking
	Directional valve on excavator may be leaking
Jaw closes suddenly and will not open	Ball valve may be partially closed on excavator
	Pilot check valves may be contaminated
	Excavator spool may be stuck
	If attachment has quick-coupled hydraulics, they may be partially disconnected or damaged
Hydraulics chatter while cutting	Tighten regen adjustment cartridge in 1/4 turns and recheck speed
	Chattering may indicate a material jam
Jaw bounces back after hitting excavator relief on jaw open	Bleed down orifice plugged
	Logix cartridge needs to be replaced
Loud bang when shifting to speed mode	Broken spring or poppet in logix cartridge
Hydraulic system overheating	Check hydraulic system oil level for low or overfull condition
	Ensure clear path for hydraulic cooler-radiator and A/C condenser; clean coolers and radiator with compressed air and pressure wash
	Check with excavator dealer on whether a hot weather package needs to be installed on the excavator. Note, oil temperatures coming out of the attachment can run as high as 230 to 240 degrees Fahrenheit.

TROUBLE-SHOOTING GUIDE

Symptom	Possible Causes/Solutions
Poor Cutting	Material is beyond attachment appetite range
	Material is harder than mild steel
	Blades are worn beyond 1/8" radius - rotate or replace
	Blade gaps are too wide for thin material
	Blade protection strips are too high, causing jaw deflection and excessive blade gaps
	Teeth and blades are worn and need to be replaced
	Too much end play in pivot group - shim to 0.002" to 0.005"
	Wear in main bearings causing jaw deflection and inconsistent blade gaps
	Pressures from excavator too low - check at attachment port blocks
	Attachment not kicking out of regeneration or kicking out at too high a pressure range - see Regeneration Valve section of manual
	Attachment swivel or cylinder is bypassing - contact Genesis Service Department for procedures to check for bypass
Material Jamming	Excessive blade gaps - shim to specs given in Cutting Blade section of manual
	Worn blades - rotate or replace
	Thin material may be wrapping around blades - fold material or draw a larger amount of material into jaws

TROUBLE-SHOOTING GUIDE

Symptom	Possible Causes/Solutions
Does not rotate	Blown fuse
	Test for 24V at plugs on directional valve while depressing foot switch
	Incorrect pressure settings; reset
	Crossover Relief Valve damaged, stuck open or out of adjustment
Does not rotate in one direction	No electrical power to one side; test for 24V at plugs on directional valve while depressing foot switch
	Check if directional control valve shifts both ways while actuating foot switch in both directions
	Crossover Relief Valve damaged, stuck open or out of adjustment
Rotator chatters	Electrical short; back out flow controls
	Pressure settings too high; reset
	Power to both rotation solenoids at the same time; test for 24V at plugs on directional valve while depressing foot switch
Rotates faster in one direction	One flow control cartridge set higher than the other; reset
Rotates too fast or too slow	Flow control out of adjustment; reset
Rotation speed changed from original setting	Jam nut loosened on rotation valve
	Faulty cartridge (contamination)
	Faulty directional control valve
	Pressure set too low; reset

WARRANTY

Claim Procedure

Notify the Genesis Service Department of the potential warranty claim prior to making the repair. Digital pictures are very helpful for diagnosing problems and recommending repairs.

Contact the Genesis Service Department before making alterations, changes or repairs to any component that is going to be considered for warranty. Not doing so will void all Genesis warranty consideration.

The Genesis Service Department will issue an authorization number to track the repair costs, outgoing parts, and/or defective parts returning to the factory.

Replacement parts must be ordered using a purchase order number. Shipping is standard ground. Overnight shipping is available by request, and Genesis will not cover the shipping charge.

When the repair is complete, submit an invoice to the Genesis Service Department within 30 days. Include itemized internal labor reporting, parts lists and invoices for outside contractors. Reference the authorization number on all invoices.

When returning parts for warranty consideration, include a copy of any related Genesis paperwork along with any other necessary documentation to ensure proper processing and credit. The Genesis Service Department will provide the necessary forms.

Your account will be credited when the warranty claim is accepted.

Blade Warranty

Standard warranty on blades will only be considered on the first edge, and wear on the edge must be 1/8" radius or less. Genesis does not warranty cutting blades that are cracked or broken from top to bottom (perpendicular to the long edge of the blade). Genesis also does not cover fasteners, the labor to replace wear components or collateral damage, such as blade seats, from broken blades, the piercing blade tang or adjustment plates.

Please direct any questions to the Genesis Service Department: 715-395-5252

PARTS ORDER POLICY AND PROCEDURE

Parts Orders Should Include

- Purchase order number
- Model and serial number of attachment
- Part number and quantity needed
- Shipping and billing address
- Method of shipment or required delivery date

Placing Orders

Orders may be placed by phone or e-mail. To e-mail an order, use the form on the following page or your purchase order form. Contact information is located at the front of this manual.

Part Numbers

Part numbers are listed in a separate Parts Manual or, if included, the Parts section of this manual. Contact the Genesis Parts Department with questions regarding part numbers, availability and pricing.

Shipping

All orders will be shipped best way surface unless an alternate shipping method is requested. Shipping charges are not included in the purchase price of parts.

Invoices

All invoices are due upon receipt. Any accounts with invoices open beyond 60 days are subject to review and may be placed on C.O.D. status without further notice.

Returns

Many unused Genesis parts may be returned with proper documentation. Return shipping is the responsibility of the purchaser. Credit will be issued upon return, less a 25% restocking fee. Documentation is required for credit of returned parts. Contact the Genesis Service Department at 715-395-5252 for an RGA (Return Goods Authorization) number and form. An RGA must accompany every return. Items shipped without an RGA may be returned to sender.

Warranty Returns

All parts returned to Genesis for warranty consideration must be returned with a completed RGA (Return Goods Authorization) provided by the Genesis Service Department. The form needs to be completed in its entirety, including any additional information requested by the Service Department. Return shipping is the responsibility of the sender and will be credited upon claim approval. A determination to accept or deny the claim will be made based upon the information available to Genesis. Warranty on purchased parts other than wear components is 6 months. There is no warranty period on wear parts or components.



PARTS ORDER FORM

Customer: _____ Date: _____
Phone: _____ Contact: _____
Shipping Address: _____ E-mail: _____

Billing Address: _____

Purchase Order: _____ Shipping Method: _____
Model: _____ Serial Number: _____

Quantity	Part Number	Description	Price

E-mail to the Genesis Parts Department: genesisparts@genesisattachments.com
For assistance, call 715-395-3488

PARTS

The following pages contain illustrations and parts lists for GDR attachments. These generalized drawings identify major components and may not be identical in fine detail to a particular attachment.

The parts lists included here are intended to aid in operation and maintenance. If further information is required, contact the Genesis Parts Department for a breakdown and parts list specific to your model and serial number.

Part numbers listed are those currently used. These may differ from the part numbers of the components originally installed in your attachment. To ensure use of the correct internal components, always indicate your attachment's model and serial numbers when ordering parts.

PARTS

Third-member Mount Upper Head

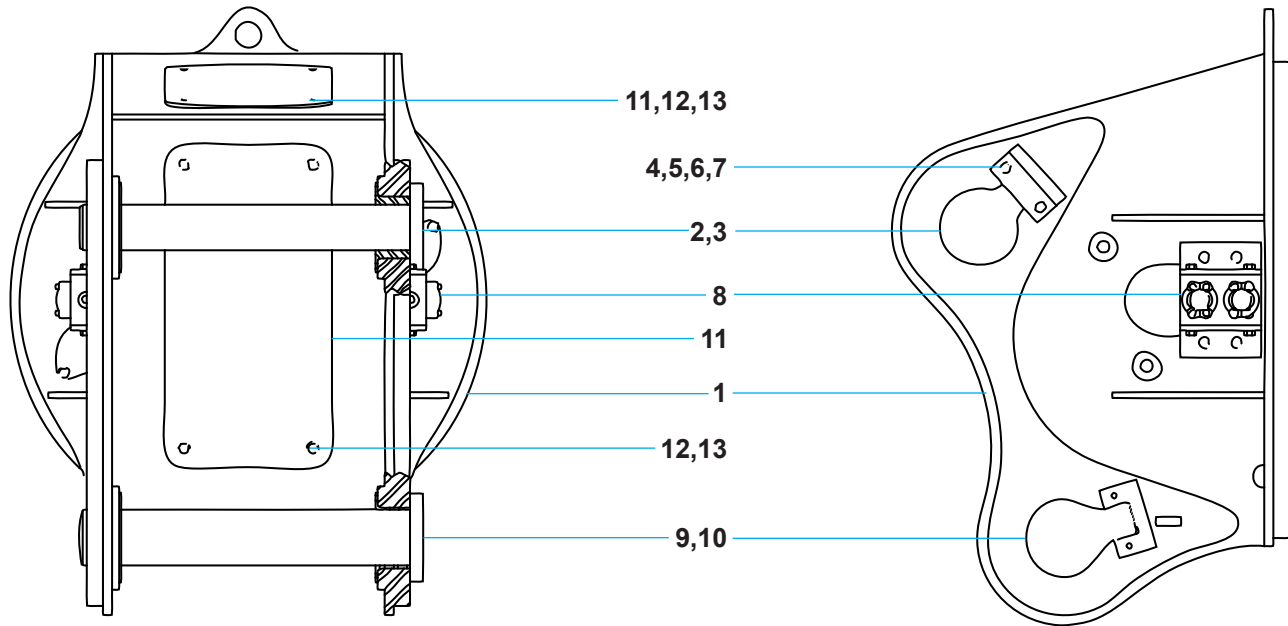

Item	Description
1	Upper head
2	Cylinder link pin
3	Spacer sleeves, where used
4	Pin keeper
5	Strap
6	Bolt (hex head capscrew)
7	Lock washer
8	Port block assembly
9	Bearings and/or spacer sleeves, where used
10	Stick pin
11	Inspection/Access cover
12	Bolt (hex head capscrew)
13	Flat washer

Custom parts - call the Genesis Parts Department for part numbers specific to your serial number.

PARTS

GDR 150/200 Cracker Jaw Configuration

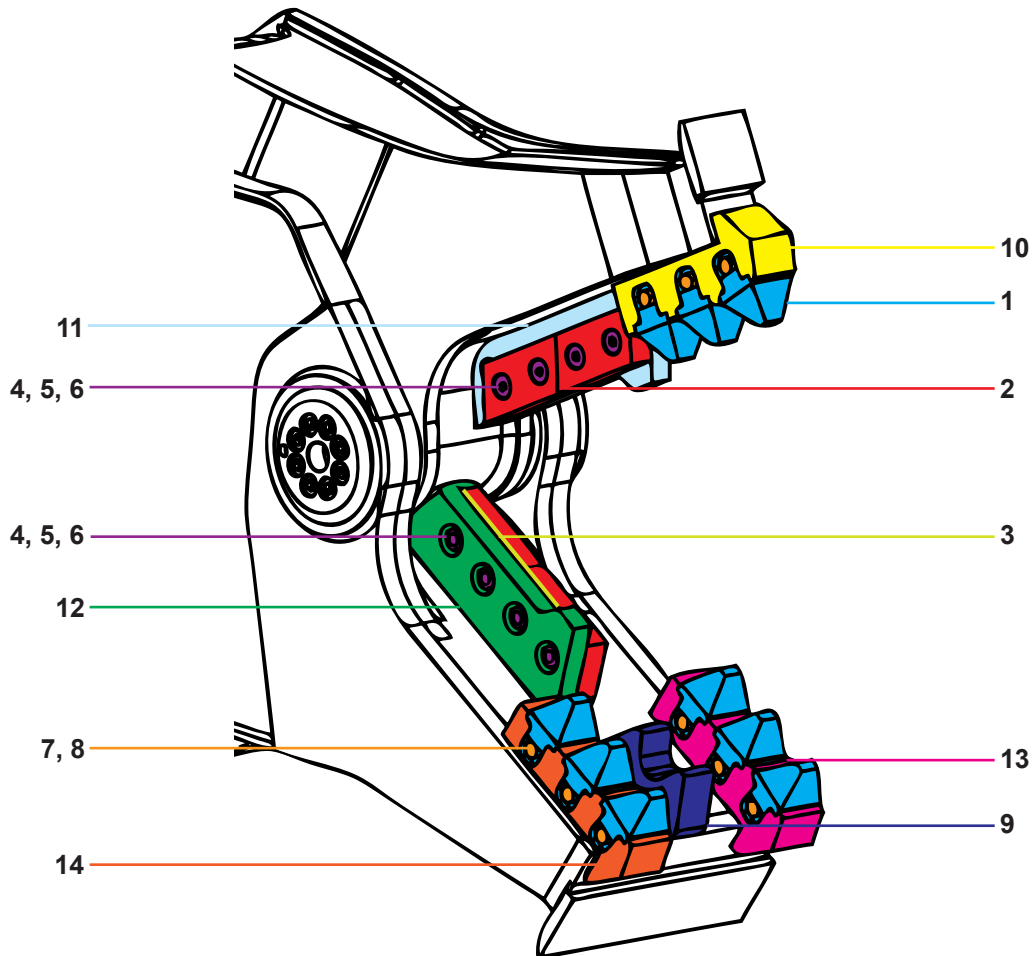

Item	Qty	Part Number		Description
		GDR 150	GDR 200	
1	9	3501009	3501009	Pulverizing tooth
2	4	4500398	1101762	Cutting blade
3	2	4500470	1102013	Shim set
4	8	F0575250	F0588350	Bolt (blade) $\frac{3}{4}$ - 10 x 2 $\frac{1}{2}$, $\frac{7}{8}$ - 9 x 3 $\frac{1}{2}$
5	8	F1300075	F1300088	Washer (blade)
6	8	F0907510	F0908809	Nut (blade)
7	9	F0275350	F0275350	Bolt (tooth) $\frac{3}{4}$ - 10 x 3 $\frac{1}{2}$
8	9	F0907510	F0907510	Nut (tooth)
9	1	N/A	3501143	Weld-in tooth
10	1	3501348	3501124	Tooth holder, upper
11	1	3501342	3501116	Blade seat, upper
12	1	3501336	3501110	Blade seat, lower
13	1	3501359	3501130	Tooth holder, lower, left
14	1	3501360	3501131	Tooth holder, lower, right

PARTS

GDR 300/400 Cracker Jaw Configuration

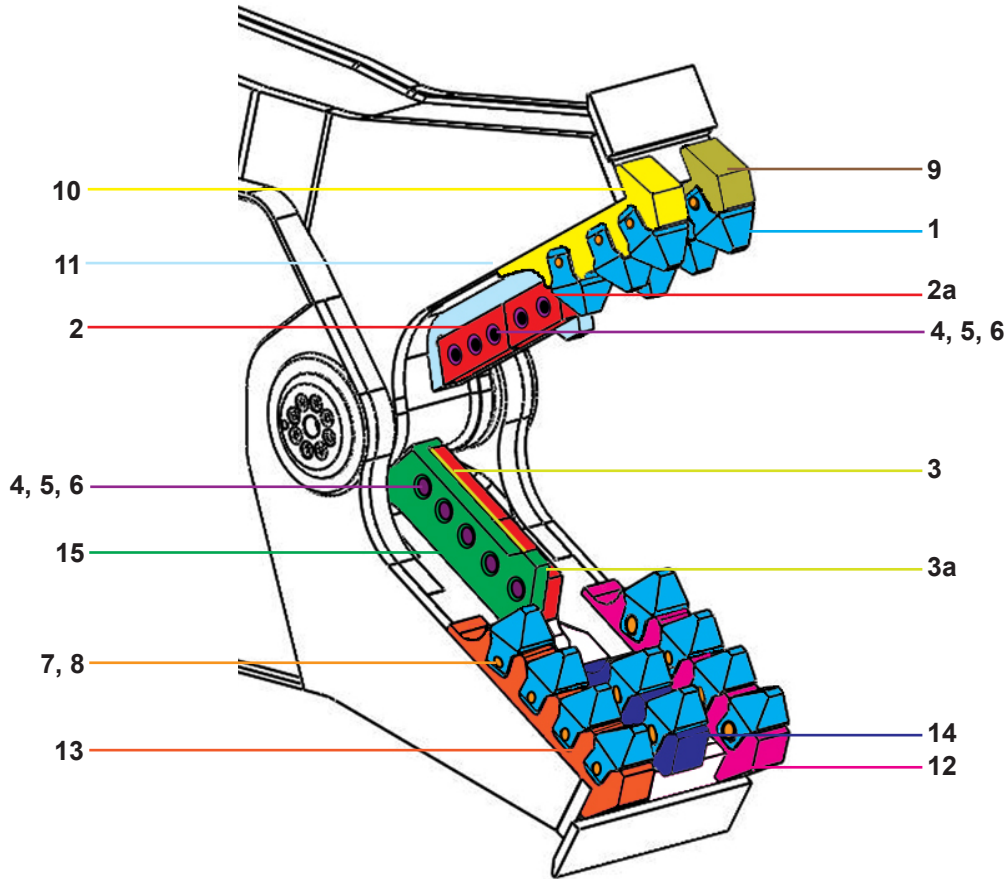

Item	Qty		Part Number		Description
	GDR 300	GDR 400	GDR 300	GDR 400	
1	16	18	3501366	3501366	Pulverizing tooth
2	2	2	1101761	1101761	Cutting blade, rear
2a	2	2	1101762	1101761	Cutting blade, front
3	1	1	3501468	3501468	Shim set, rear
3a	1	1	1102013	3501468	Shim set, front
4	8	8	F0588350	F0588350	Bolt (blade) $\frac{7}{8}$ - 9 x 3 $\frac{1}{2}$
5	8	8	F1300088	F1300088	Washer (blade)
6	8	8	F0908809	F0908809	Nut (blade)
7	16	18	F0288400	F0288400	Bolt (tooth) $\frac{7}{8}$ - 9 x 4
8	-	-	N/A	N/A	Nut (tooth)
9	1	1	3501462	3501455	Tooth holder, upper left-hand
10	1	1	3501464	3501454	Tooth holder, upper right-hand
11	1	1	3501466	3501825	Blade seat, upper
12	1	1	3501454	3501454	Tooth holder, lower left-hand
13	1	1	3501455	3501455	Tooth holder, lower right-hand
14	1	1	3501458	3501831	Tooth holder, lower center
15	1	1	3501460	3501828	Blade seat, lower

PARTS

GDR 150/200 Pulverizer Jaw Configuration

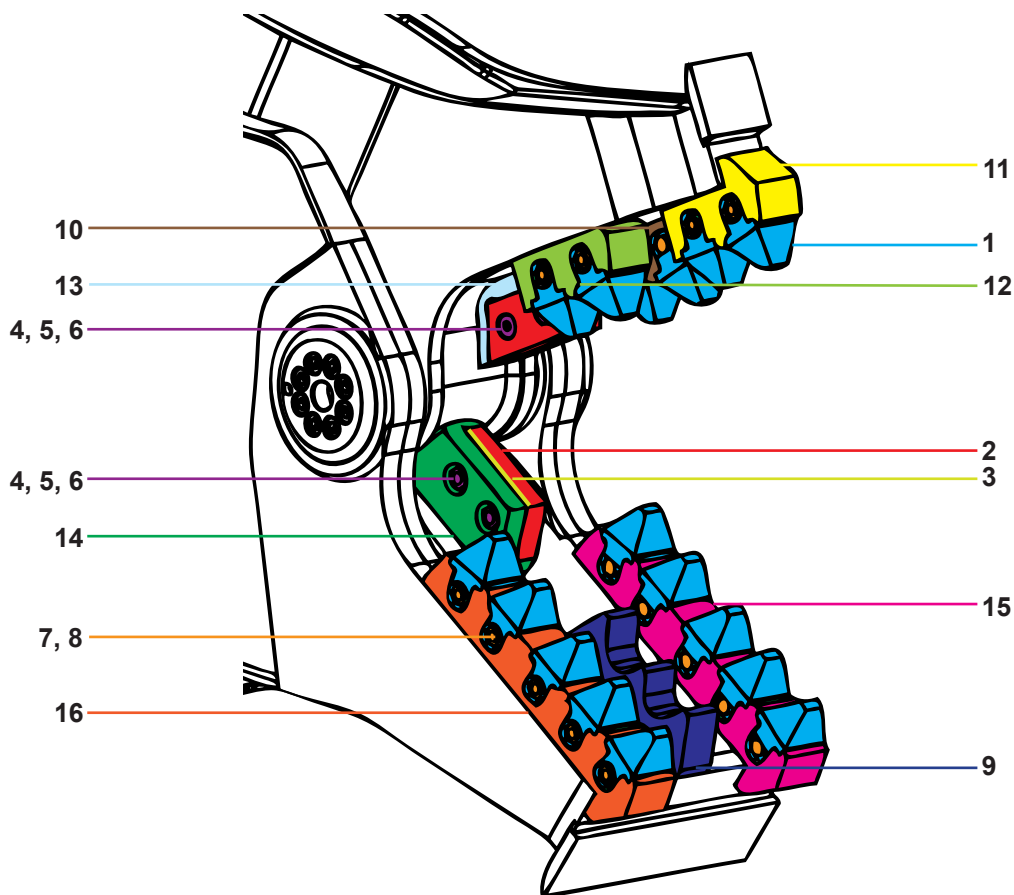

Item	Qty		Part Number		Description
	GDR 150	GDR 200	GDR 150	GDR 200	
1	12	16	3501009	3501009	Pulverizing tooth
2	2	2	4500398	1101762	Cutting blade
3	1	1	4500470	1102013	Shim set
4	4	4	F0575250	F0588350	Bolt (blade) $\frac{3}{4}$ - 10 x 2 $\frac{1}{2}$, $\frac{7}{8}$ - 9 x 3 $\frac{1}{2}$
5	4	4	F1300075	F1300088	Washer (blade)
6	4	4	F0907510	F0908809	Nut (blade)
7	12	16	F0275350	F0275350	Bolt (tooth) $\frac{3}{4}$ - 10 x 3 $\frac{1}{2}$
8	12	16	F0907510	F0907510	Nut (tooth)
9	1	1	N/A	3501144	Weld-in tooth
10	1	1	N/A	3501129	Tooth holder, upper, left
11	1	1	3501350	3501122	Tooth holder, upper, center
12	1	1	N/A	3501129	Tooth holder, upper, right
13	1	1	3501340	3501114	Blade seat, upper
14	1	1	3501334	3501108	Blade seat, lower
15	1	1	3501361	3501132	Tooth holder, lower, left
16	1	1	3501362	3501133	Tooth holder, lower, right

PARTS

GDR 300/400 Pulverizer Jaw Configuration

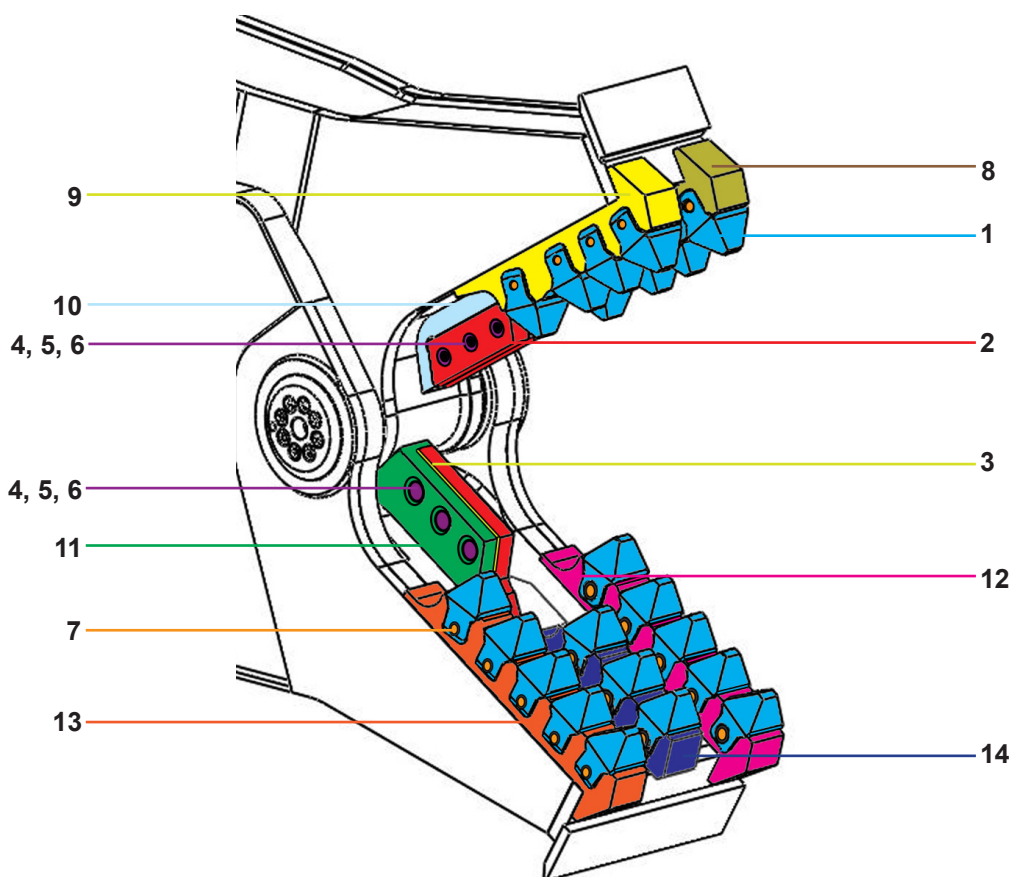

Item	Qty		Part Number		Description
	GDR 300	GDR 400	GDR 300	GDR 400	
1	21	23	3501366	3501366	Pulverizing tooth
2	2	2	1101252	1101251	Cutting blade
3	1	1	3501469	1100286	Shim set
4	6	6	F0588350	F0288400	Bolt (blade) $\frac{7}{8}$ - 9 x 3 $\frac{1}{2}$, $\frac{7}{8}$ - 9 x 4
5	6	6	F1300088	F1300088	Washer (blade)
6	6	6	F0908809	F0908809	Nut (blade)
7	21	23	F0288400	F0288400	Bolt (tooth) $\frac{7}{8}$ - 9 x 4
8	1	1	3501380	3501386	Tooth holder, upper, left
9	1	1	3501378	3501385	Tooth holder, upper, right
10	1	1	3501382	3501855	Blade seat, upper
11	1	1	3501389	3501853	Blade seat, lower
12	1	1	3501385	3501385	Tooth holder, lower, left
13	1	1	3501386	3501386	Tooth holder, lower, right
14	1	1	3501446	3501851	Tooth holder, lower center

PARTS

GDR 150/200 Shear Jaw Configuration

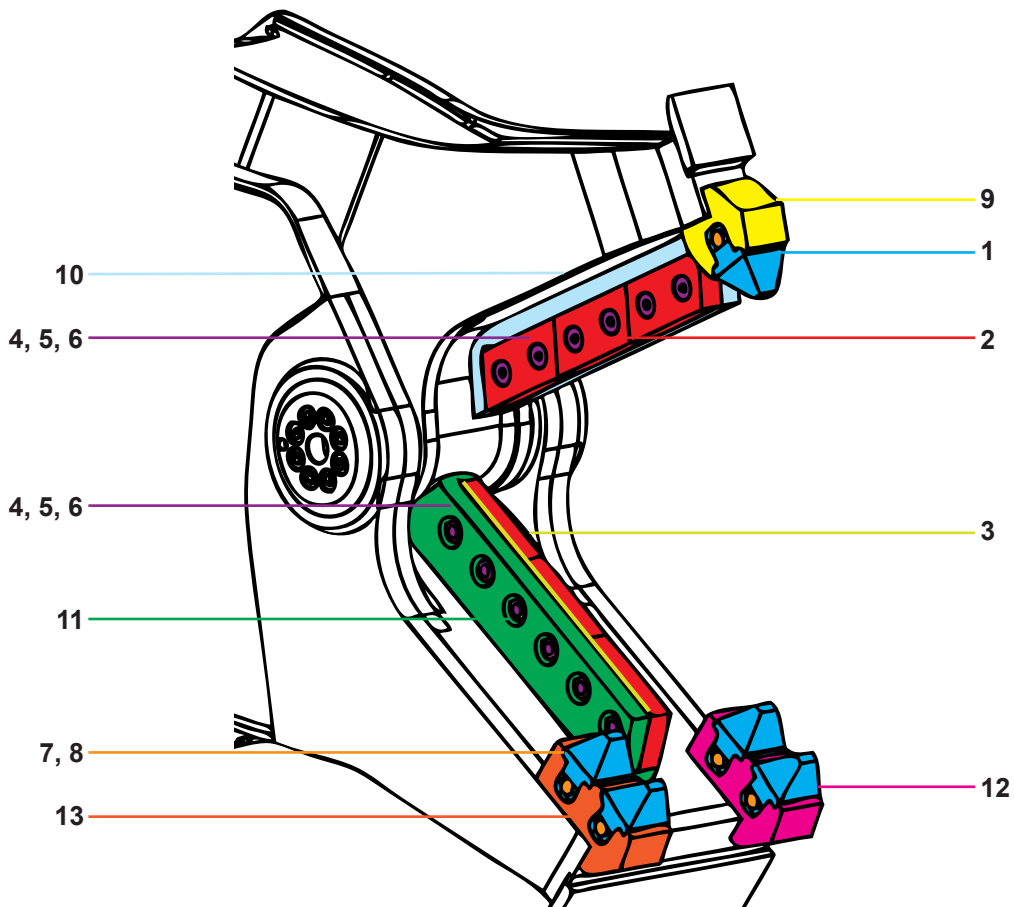

Item	Qty	Part Number		Description
		GDR 150	GDR 200	
1	5	3501009	3501009	Pulverizing tooth
2	6	4500398	1101762	Cutting blade
3	3	4500470	1102013	Shim set
4	12	F0575250	F0588350	Bolt (blade) $\frac{3}{4}$ - 10 x 2 $\frac{1}{2}$, $\frac{7}{8}$ - 9 x 3 $\frac{1}{2}$
5	12	F1300075	F1300088	Washer (blade)
6	12	F0907510	F0908809	Nut (blade)
7	5	F0275350	F0275350	Bolt (tooth) $\frac{3}{4}$ - 10 x 3 $\frac{1}{2}$
8	5	F0907510	F0907510	Nut (tooth)
9	1	3501346	3501120	Tooth holder, upper
10	1	3501344	3501118	Blade holder, upper
11	1	3501338	3501112	Blade holder, lower
12	1	3501357	3501127	Tooth holder, lower, left
13	1	3501358	3501128	Double tooth holder, lower, right

PARTS

GDR 300 Shear Jaw Configuration

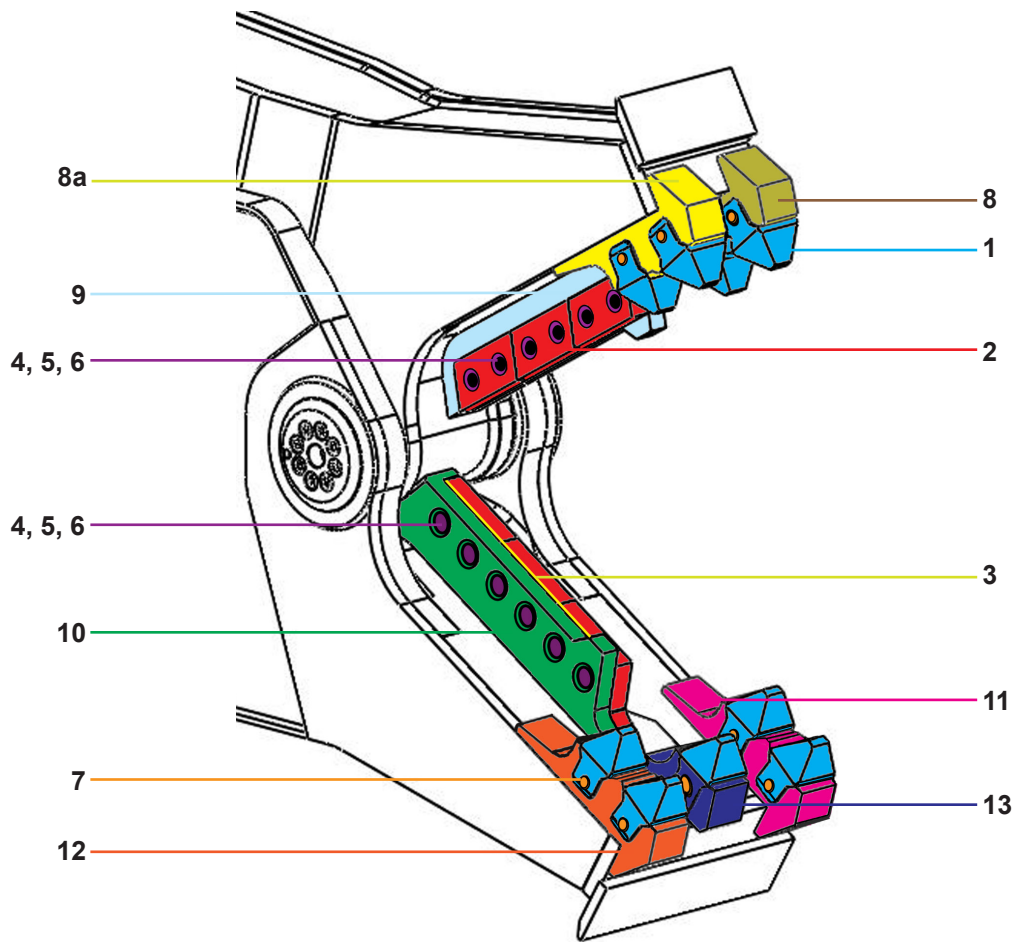

Item	Qty	Part Number	Description
1	9	3501366	Pulverizing tooth
2	6	1101762	Cutting blade
3	3	1102013	Shim set
4	12	F0588350	Bolt (blade) $\frac{7}{8}$ - 9 x 3 $\frac{1}{2}$
5	12	F1300088	Washer (blade)
6	12	F0908809	Nut (blade)
7	9	F0288400	Bolt (tooth) $\frac{7}{8}$ - 9 x 4
8	1	3501482	Tooth holder, upper left-hand
8a	1	3501479	Tooth holder, upper right-hand
9	1	3501488	Blade holder, upper
10	1	3501486	Blade holder, lower
11	1	3501478	Tooth holder, lower, left
12	1	3501479	Tooth holder, lower, right
13	1	3501484	Tooth holder, lower, center

PARTS

GDR 150 Pivot and Pins

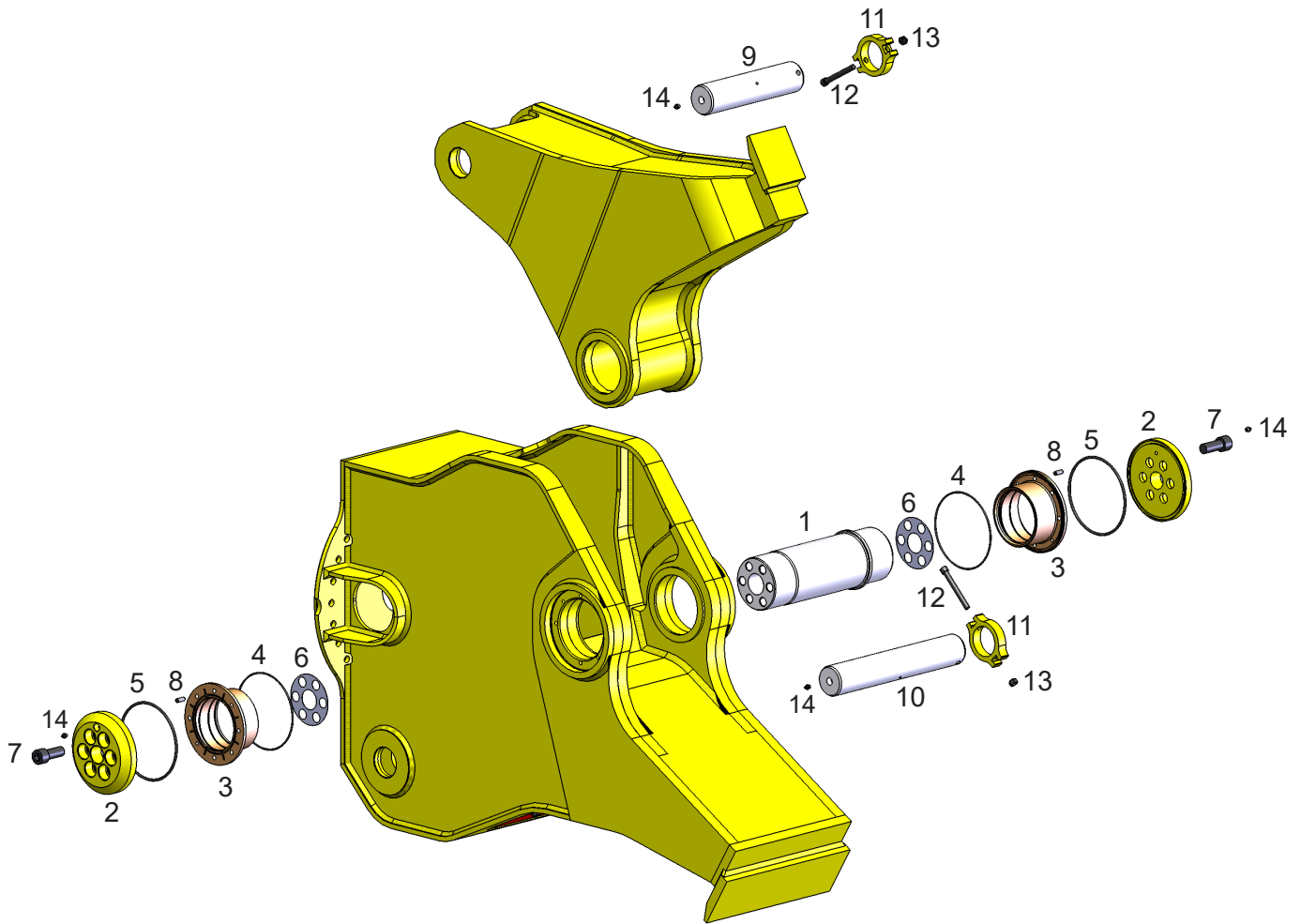

Item	Qty	Part Number	Description
1	1	3501322	Shaft
2	2	3501318	End cap
3	2	3501320	Bearing
4	2	S0190264	O-ring (bearing)
5	2	S0190367	O-ring (end cap)
6	2	3501268	Shim set
7	16	F0624060	End cap bolt
8	4	6200066	Dowel pin
9	1	3501321	Cylinder upper pin
10	1	3501323	Cylinder stick pin
11	2	3501244	Pin keeper
12	2	F0612110*	Bolt (pin keeper)
13	2	F1012175	Nut (pin keeper)
14	4	6200002	Grease Fitting

* M12 x 1 x 110

PARTS

GDR 200 - 400 Pivot and Pins

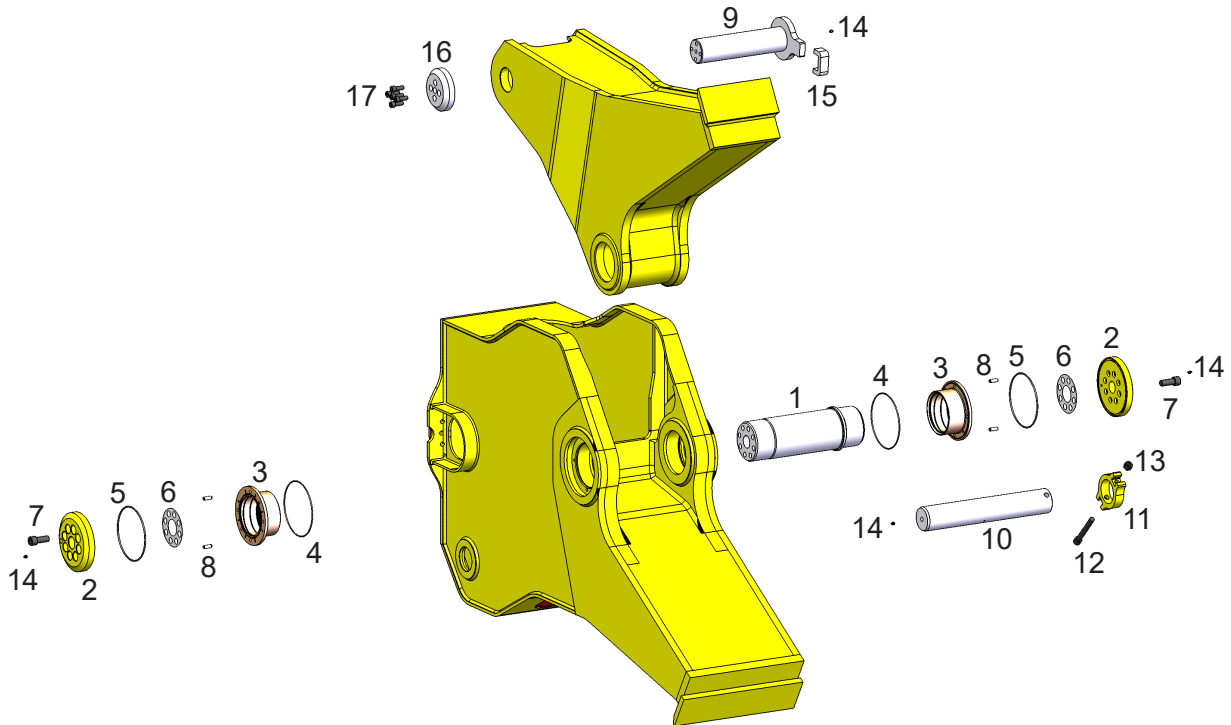

Item	Qty	Part Number			Description
		GDR 200	GDR 300	GDR 400	
1	1	3501105	3501440	3501810	Shaft
2	2	3501099	3501099	3501812	End Cap
3	2	3501100	3501100	3501760	Bearing
4	2	S0190270	S0190270	S0190274	O-Ring (Bearing)
5	2	S0190372	S0190372	S0190376	O-Ring (End Cap)
6	2	3500360	3500360	3501761	Shim Set
7	16	F0624060	F0624060	F0624060	Pivot End Cap Bolt
8	4	6300134	6300134	6300134	Dowel Pin
9	1	3501741	3501694	3501806	Cylinder Upper Pin
10	1	3501101	3501442	3501805	Cylinder Stick Pin
11	1	3500831	3500309	1103607	Pin Keeper (Stick Pin)
12	1	F0616150*	F0620160**	F0620180***	Bolt (Pin Keeper)
13	1	F1016200	F1020250	F1020250	Nut (Pin Keeper)
14	4	6200002	6200002	6200002	Grease Fitting
15	1	4502533	4502533	4502533	Pin Keeper (Upper Pin)
16	1	3501742	3501695	3501808	End Cap (Upper Pin)
17	5	F0616040	F0616040	F0616040	Upper End Cap Bolt

* M16 x 2 x 150

** M20 x 2.5 x 160

***M20 x 2.5 x 180

PARTS

GDR 150 Cylinder Assembly

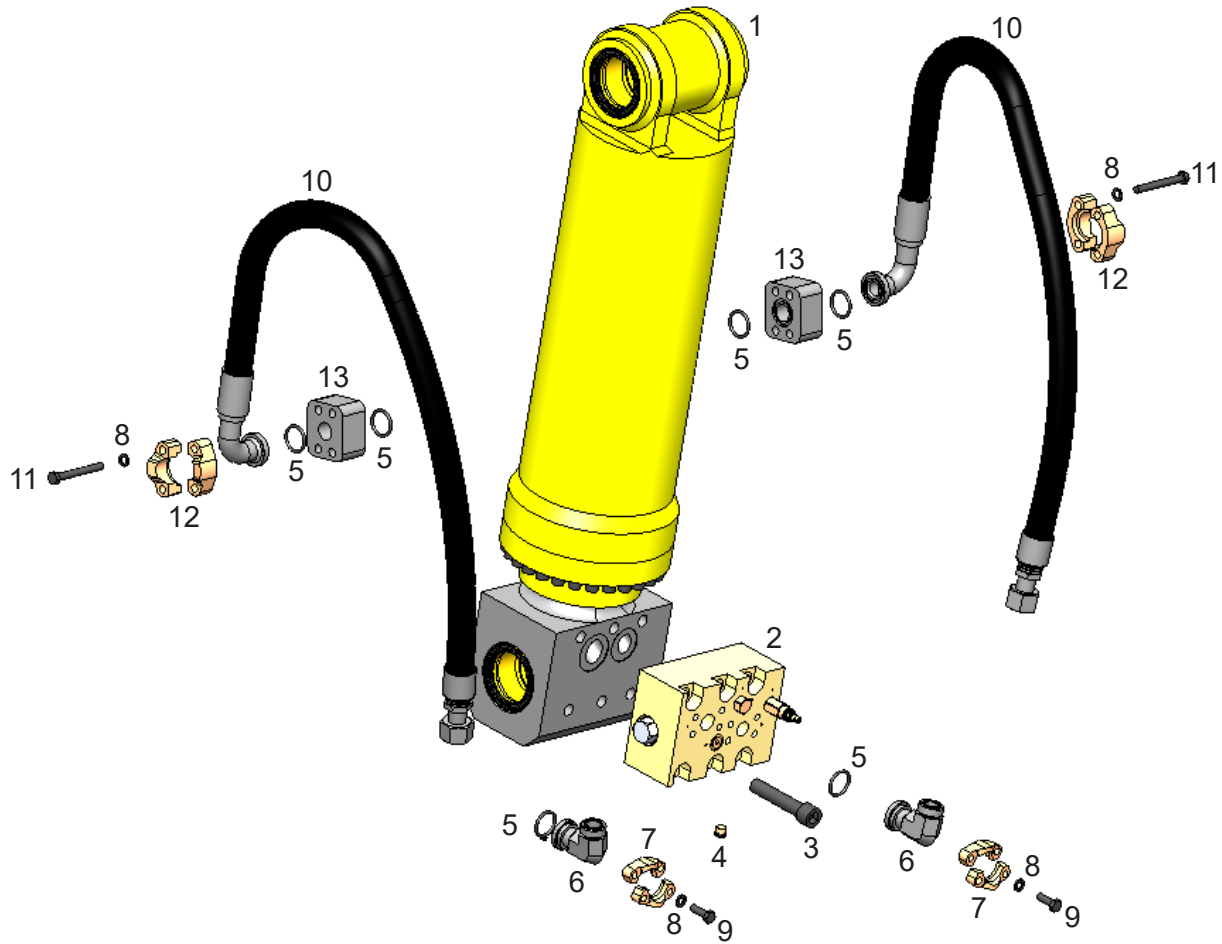

Item	Qty	Part Number	Description
1	1	*	Cylinder
2	1	6360004	Regeneration Valve
3	6	F0620100	Socket Head Capscrew M20 x 2.5 x 100
4	1	6300153	Plug 06MB
5	6	S0190219	O-Ring
6	2	6310004	Adapter
7	4	H0261100	Split Flange
8	16	F1401000	Lock Washer M10
9	4	F0110030	Hex Head Capscrew M10 x 1.5 x 30
10	2	5300377	Hose
11	8	F0110090	Hex Head Capscrew M10 x 1.50 x 90
12	4	H0262100	Split Flange
13	2	6310161	Adapter Spacer

* Part number is Serial Number specific. For replacement parts call the Genesis Parts Department.

USA
715-395-3488

Europe
+49 83 31 9 25 98 0

PARTS

GDR 200 Cylinder Assembly

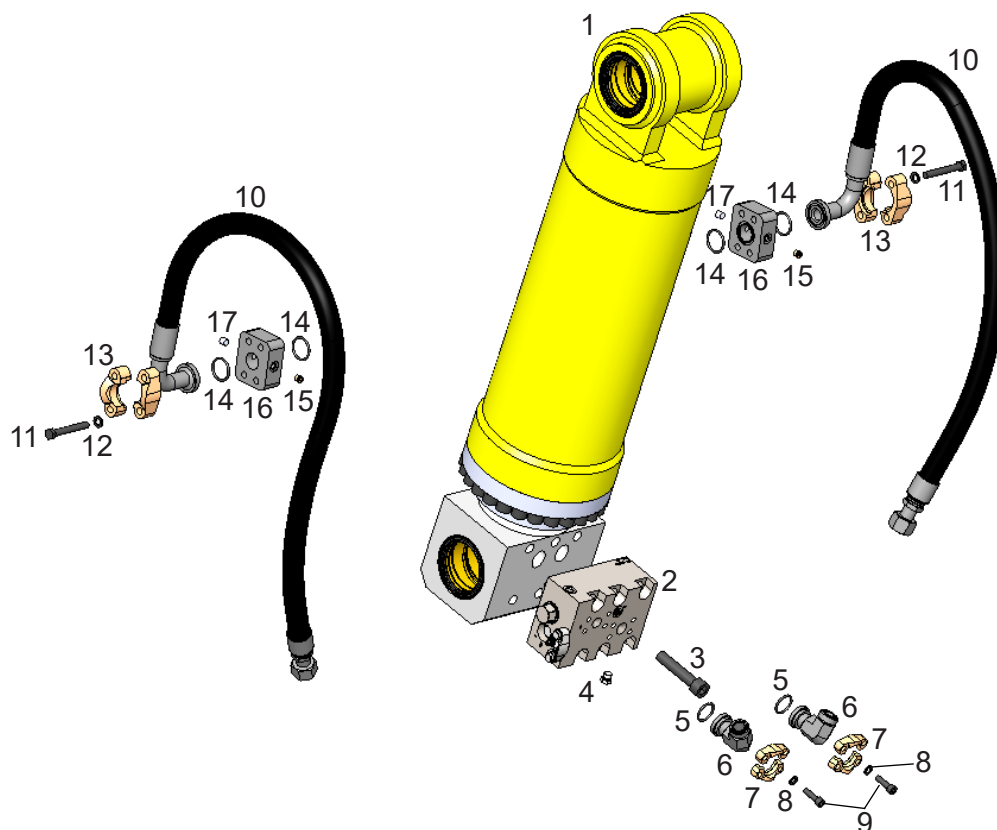

Item	Qty	Part Number	Description
1	1	*	Cylinder
2	1	6301255	Regeneration Valve
3	6	F0620100	Socket Head Capscrew M20 x 2.5 x 100
4	1	6300021	Plug 06MB
5	2	S0190219	O-Ring
6	2	6310004	Adapter
7	4	H0261100	Split Flange
8	8	F1401000	Lock Washer M10
9	8	F0610035	Socket Head Capscrew M10 x 1.50 x 35
10	2	5300465	Hose
11	8	F0112090	Hex Head Capscrew M12 x 1.75 x 90
12	8	F1401200	Lock Washer M12
13	4	H0262125	Split Flange
14	4	S0190222	O-Ring
15	2	6300076	Plug 04MB
16	2	6310148	Adapter Spacer
17	2	6300582	Plug 04MP

* Part number is Serial Number specific. For replacement parts call the Genesis Parts Department.

USA

715-395-3488

Europe

+49 83 31 9 25 98 0

PARTS

GDR 300 Cylinder Assembly

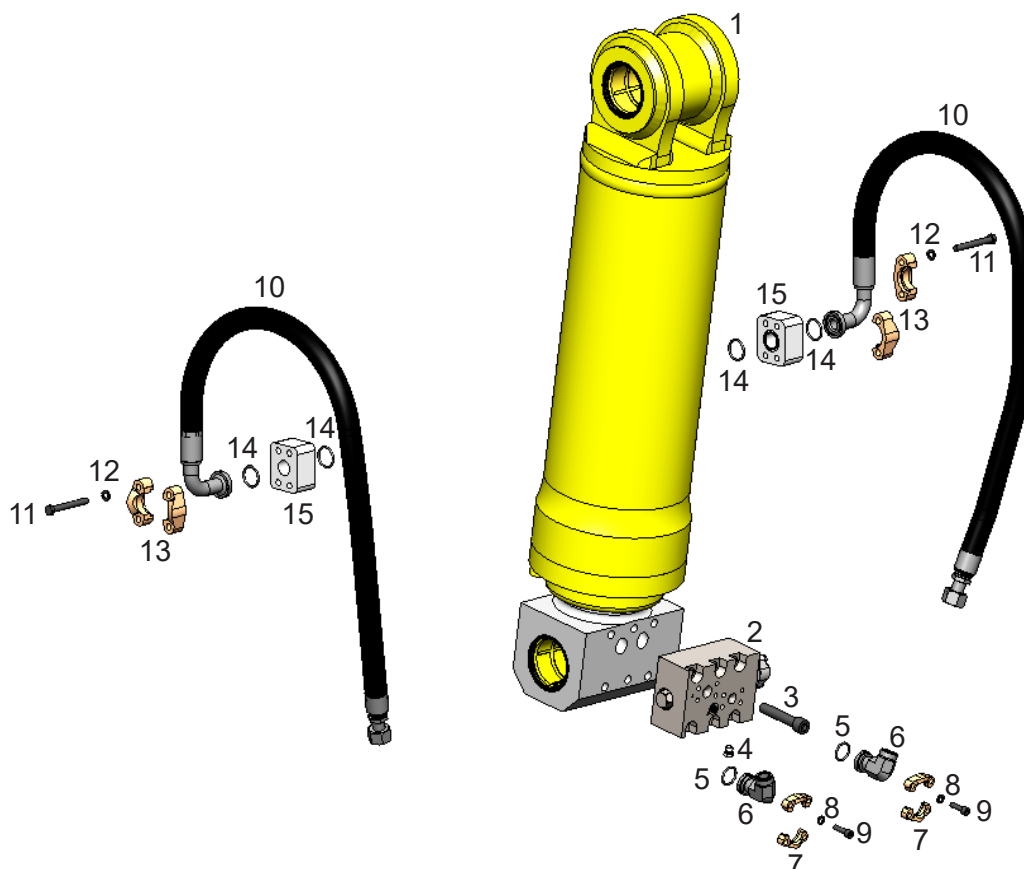

Item	Qty	Part Number	Description
1	1	*	Cylinder
2	1	6301255	Regeneration Valve
3	6	F0620100	Socket Head Capscrew M20 x 2.5 x 100
4	1	6300021	Plug 06MB
5	2	S0190219	O-Ring
6	2	6310004	Adapter
7	4	H0261100	Split Flange
8	8	F1401000	Lock Washer M10
9	8	F0610035	Socket Head Capscrew M10 x 1.50 x 35
10	2	5300406	Hose
11	8	F0112100	Hex Head Capscrew M12 x 1.75 x 100
12	8	F1401200	Lock Washer M12
13	4	H0262125	Split Flange
14	4	S0190222	O-Ring
15	2	6310164	Adapter Spacer

* Part number is Serial Number specific. For replacement parts call the Genesis Parts Department.

USA

715-395-3488

Europe

+49 83 31 9 25 98 0

PARTS

GDR 400 Cylinder Assembly

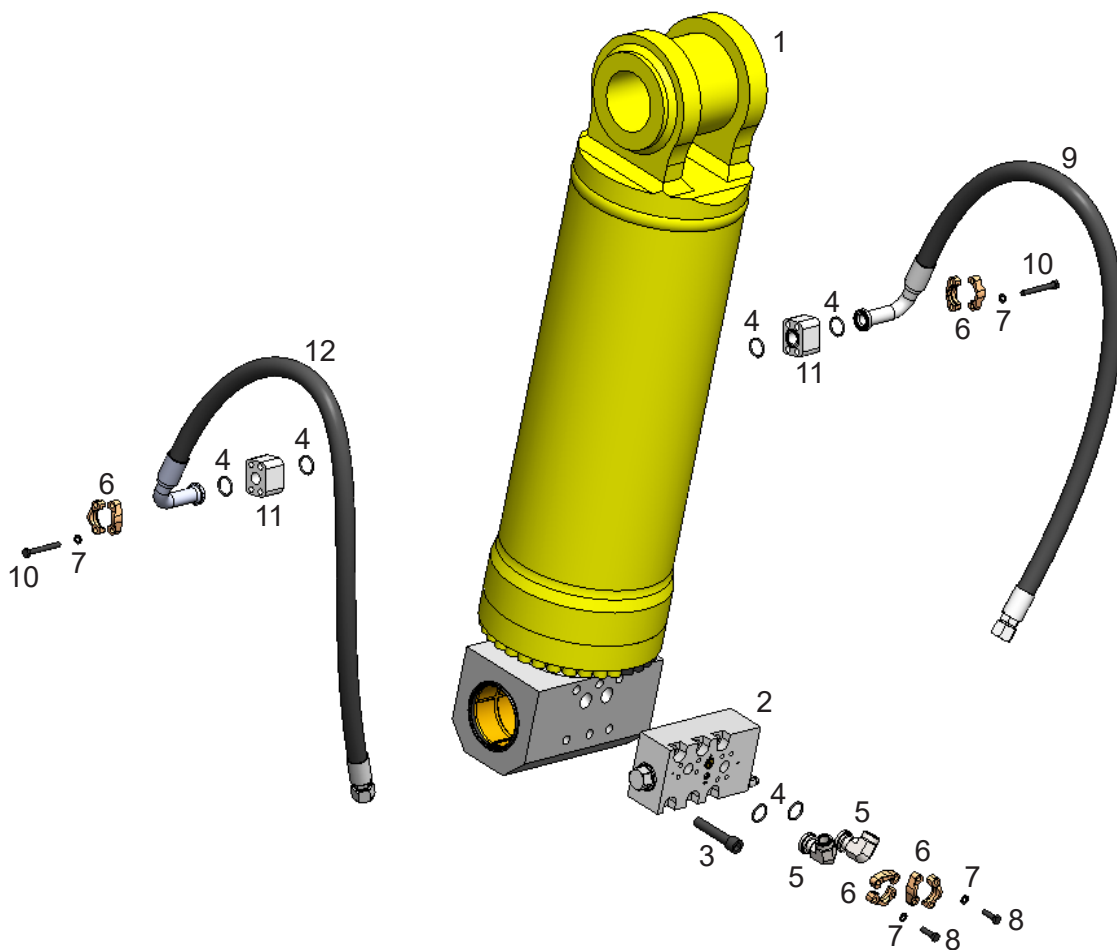

Item	Qty	Part Number	Description
1	1	*	Cylinder
2	1	6301254	Regeneration Valve
3	6	F0620100	Socket Head Capscrew M20 x 2.50 x 100
4	6	S0190219	O-Ring
5	2	6310004	Adapter
6	8	H0261100	Split Flange
7	16	F1401000	Lock Washer M10
8	8	F0110035	Hex Head Capscrew M10 x 1.5 x 35
9	1	3501823	Hose
10	8	F0110090	Hex Head Capscrew M10 x 1.5 x 90
11	2	6310178	Adapter Spacer
12	1	3501822	Hose

* Part number is Serial Number specific. For replacement parts call the Genesis Parts Department.

USA
715-395-3488

Europe
+49 83 31 9 25 98 0

PARTS

Rotation Drive System

GDR 150

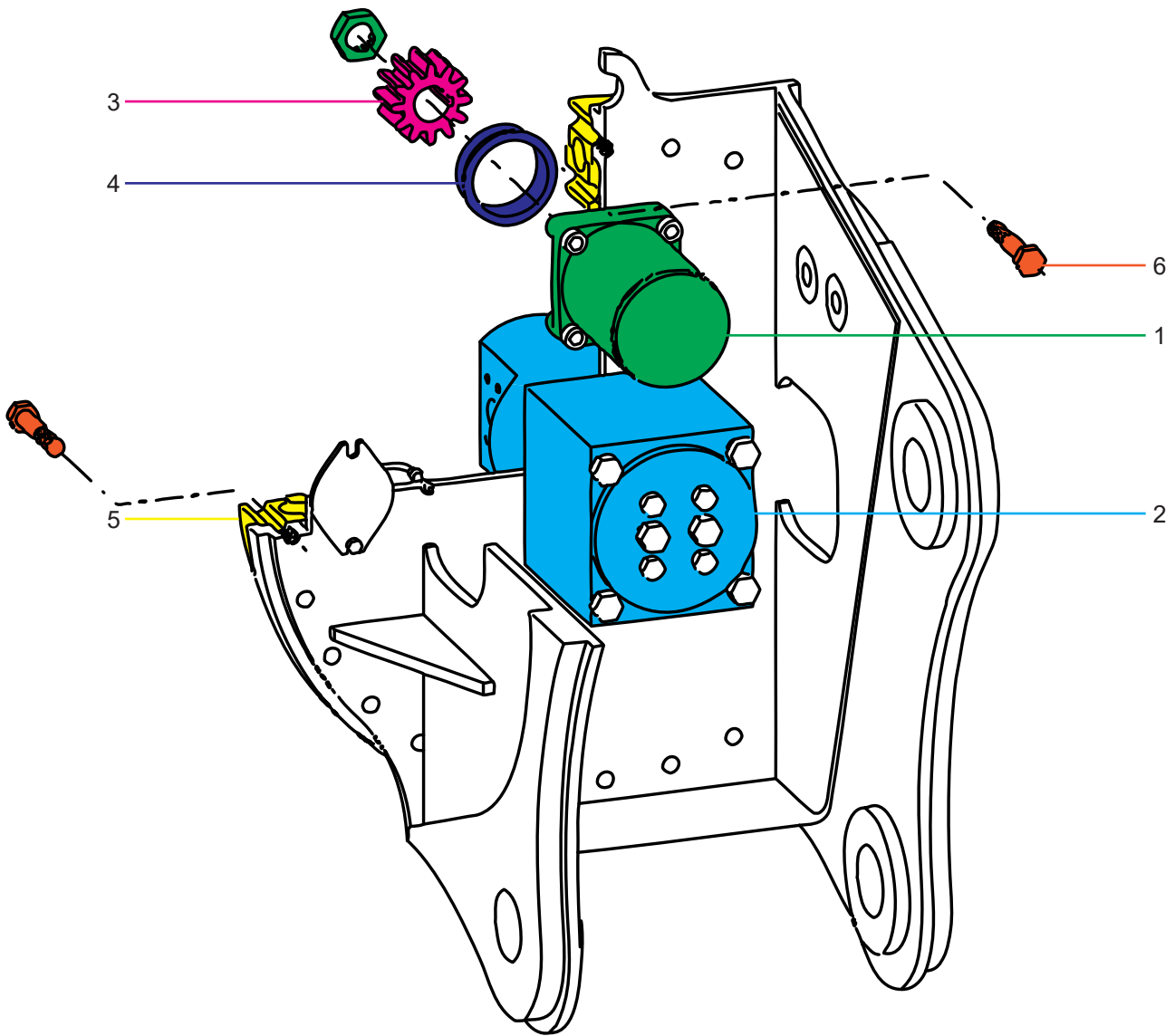

Item	Description	Part Number
1	Motor	6380100
2	Swivel Assy	63500029
3	Pinion	3502192
4	Spacer	1107014
5	Rotation Brg	6100397
6	Bolts M20 x 2.5 x 90	F0120090 (qty 56)

PARTS

GDR 200 & 300

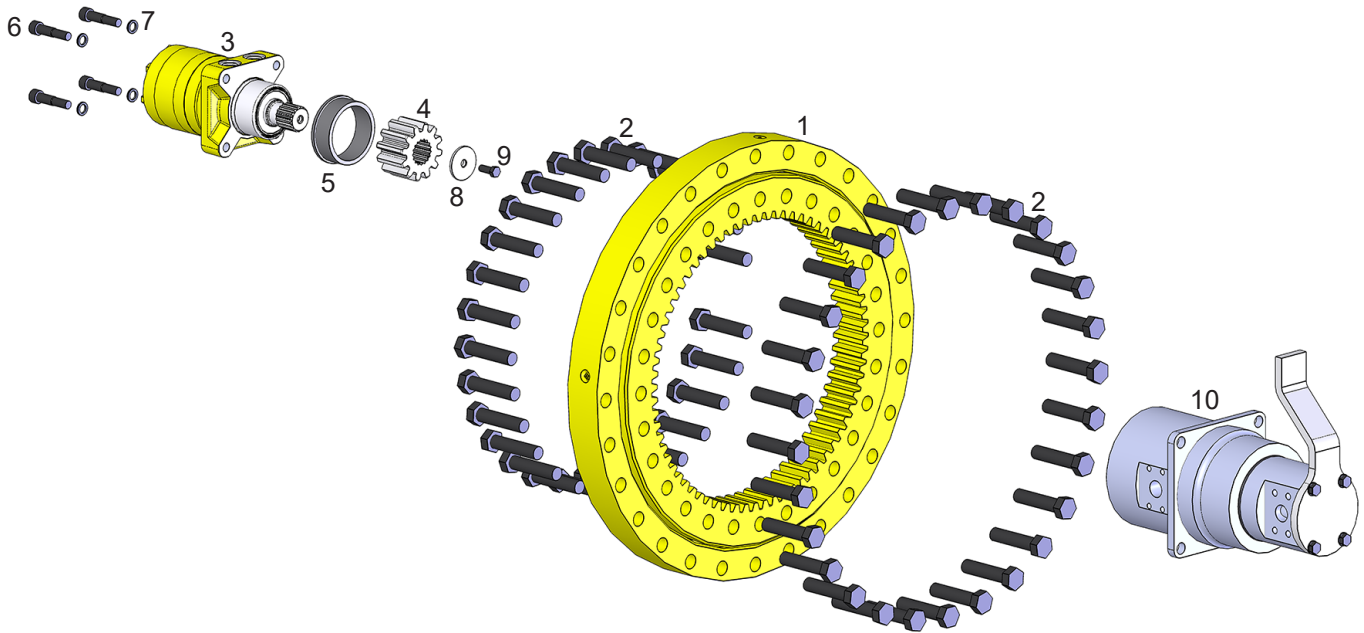

		Part Number	
Item	Qty	GDR 200 & 300	Description
1	1	6100092	Bearing Slewing
2	66	F0120100	Hex Head Capscrew M20 x 2.50 x 100
3	1	6380084	Motor
4	1	3101225	Pinion
5	1	1107014	Mach Spacer
6	4	1108183	Mach Bolt Socket Head Capscrew
7	4	F1900050	Washer Nord Lock
8	1	3101226	Mach Washer Motor Pinion
9	1	F0238100	Hex Head Capscrew $\frac{3}{8}$ - 16 x 1
10	1	6350066	Assy Swivel Manifold

PARTS

GDR 400

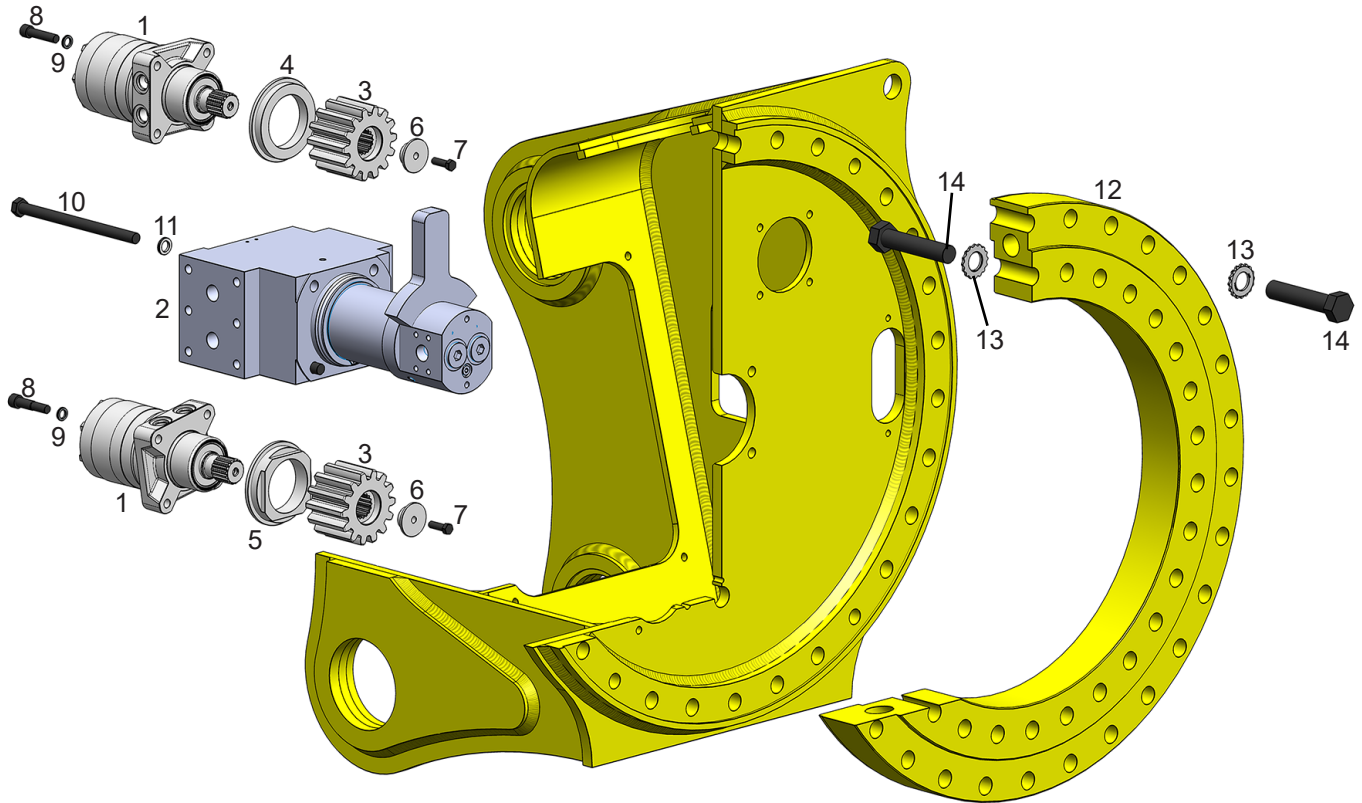

Item	Qty	Part Number	Description
1	2	6380084	Motor
2	1	6350173	Swivel Assembly
3	2	3101224	Pinion
4	1	3101835	Spacer
5	1	3501914	Spacer
6	2	3501836	Washer
7	2	F0238125	Bolt $\frac{3}{8}$ - 16 x $1\frac{1}{4}$
8	8	1108183	Bolt - Custom M12 x 1.75
9	8	F1900050	Nord Lock Washer
10	4	F0116240	Bolt M16 x 2 x 240
11	4	F1900063	Nord Lock Washer
12	1	6300429	Rotation Brg
13	60	F2802700	Hytorc Washer
14	60	F0127130	Bolt M27 x 3 x 130

TOOL LIST

The following is a list of tools available for purchase from Genesis. This list may not include every tool used for this attachment, such as those that would also commonly be used for maintaining an excavator.

Part Number	Description
6900007	BHWW-1173FP 1 1/4" Combination Wr 12 Pt
6900016	BHWW-1167FP 7/8" Combination Wr 12 Pt
6900017	BHWW-1172FP 1 1/8" Combination Wr 12 Pt
6900030	9/16" Combination Wr 12 Pt
6900031	11/16" Combination Wr 12 Pt
6900035	15/16" Combination Wr 12 Pt
6900038	1 1/2" Combination Wr 12 Pt
6900039	1 5/8" Combination Wr 12 Pt
6900044	3/8' Ratchet Drive
6900045	1/2' Ratchet Drive
6900049	7/16" 12PT Socket (3/8" Drive)
6900055	10 Piece SAE Allen Wr Set (1/16-3/8")
6900058	3" Drive Extension (1/2" Drive)
6900059	6" Drive Extension (1/2" Drive)
6900060	9" Drive Extension (1/2" Drive)
6900061	10mm 12PT Socket (1/2" Drive)
6900062	17mm 12PT Socket (1/2" Drive)
6900063	19mm 12PT Socket (1/2" Drive)
6900064	24mm 12PT Socket (1/2" Drive)
6900065	8mm Allen Socket (1/2" Drive)
6900066	17mm Allen Socket (1/2" Drive)
6900067	3/4" Ratchet Drive
6900068	1 5/16" 12PT Socket (3/4" Drive)
6900069	30mm 12PT Socket (3/4" Drive)
6900070	3/4" Allen Socket (3/4" Drive)
6900071	17mm Allen Socket (3/4" Drive)
6900072	5/8" Combination Wr 12 Pt
6900073	1 1/16" Combination Wr 12 Pt
6900074	17mm Combination Wr 12 Pt
6900075	1 1/8" 12PT Socket (3/4" Drive)

BOLT TORQUE SPECIFICATIONS

Reference the product Thread Treatment Diagram on page 71 to determine whether to use wet or dry torque values for specific bolts.

Reference Procedures on page 72 for threadlocker or anti-seize application and bolt and bolt hole cleaning.

Prior to torquing, clean all bolt holes, bolts and nuts to remove dirt, grease and oil, and identify bolt type.

Never re-torque bolts that use Loctite. If a bolt becomes loose or damaged after the initial use when Loctite was applied and the bolt was torqued, the bolt must be replaced.

Never break tightened bolts loose with a torque wrench. Doing so may break the torque wrench or take it out of calibration.

Torque wrenches should be calibrated on an annual basis.

When using a torque multiplier with a torque wrench, incorrect settings will be multiplied by the ratio of the torque wrench.

Never use an impact driver on a torque multiplier.

THREAD TREATMENT DIAGRAM

Processors

Use this diagram to determine what thread treatment, if any, is required for each fastener.

For thread treatment application procedures, see page 72. For prescribed torque values, see page 74.

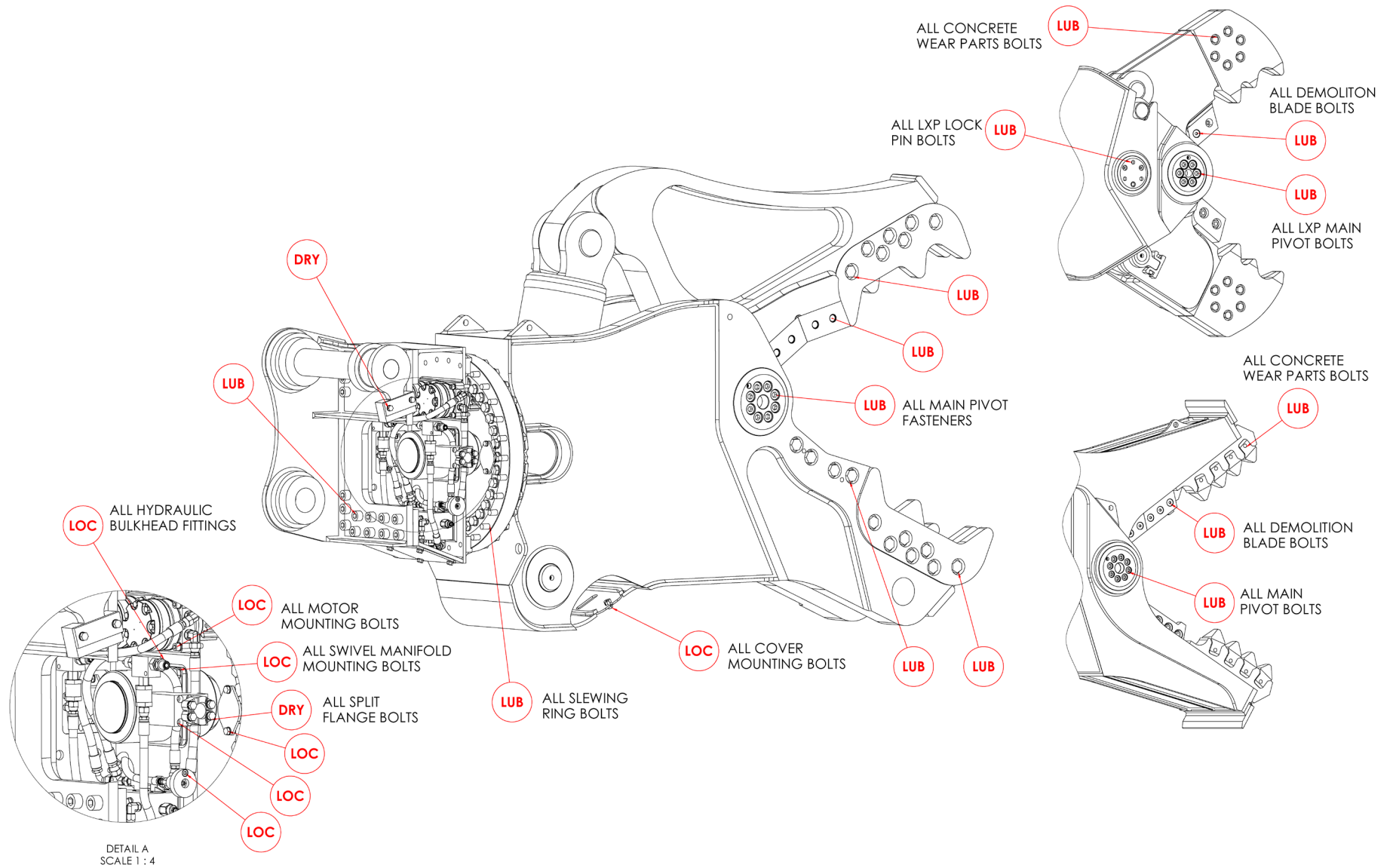

PROCEDURES

Reference the product Thread Treatment Diagram on page 71 to determine which of the following procedures is required.

Cleaning

To ensure proper performance of thread treatment and accurate torque values, clean and degrease **all internal and external threads** prior to application of threadlocker, anti-seize or primer and before installation of hardware.

- Ensure both internal and external threads are free of dirt or debris.
- Use brake cleaner or similar cleaning solvent on all threads to remove any grease or oil.
- Allow threads to dry.

NOTICE

Failure to properly clean threads will cause threadlocker, primer, and/or anti-seize to not properly cure!

LOC

Threadlocker

For bolted connections requiring threadlocker, use **Loctite 263** or equivalent applied using the following procedure:

- Clean and degrease all threads.
- For thru holes or nuts, apply threadlocker to bolt threads.
- For blind holes, apply stripe of threadlocker along the length of the hole (applying to the bolt can cause escaping air to remove threadlocker as the bolt is inserted).
- Torque bolt to specified **Wet Torque Value**, see page 74.

For threaded hydraulic fitting connections, use **Loctite 5452** or equivalent thread sealant in conjunction with **Loctite 7471** primer using the following procedure:

- Clean and degrease all threads.
- Apply Loctite 7471 primer to both external and internal threads and allow to dry.
- Apply threadlocker to 360 degrees of the threads on the male fitting, ensuring adequate coverage.
- Assemble fitting per directions in operator's manual.
- For O-ring boss and flat face O-ring connections, torque fittings to values specified on page 75.

Threadlocker

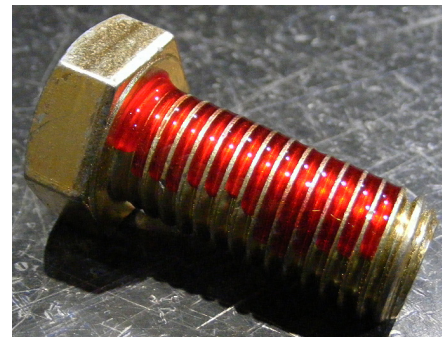

Blind Hole

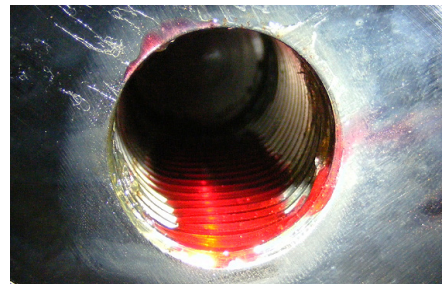

Hydraulic Fitting



PROCEDURES

LUB

Anti-Seize

For bolted connections requiring anti-seize lubrication, use **Loctite LB8008** or equivalent using the following procedure:

- Clean and degrease all threads.
- Apply thin coat of anti-seize to internal and external threads and under bolt head and/or nut, ensuring complete coverage.
- Torque bolt to specified **Wet Torque Value**, see page 74.

Anti-Seize







DRY

No Thread Treatment

- Clean and degrease all threads.
- Torque bolt to specified **Dry Torque Value**, see page 74.

BOLT TORQUE SPECIFICATIONS

Dry Torque Values					
		Hex/Socket Head		Flat Head	
					
Fastener Grade	Size x Pitch	Nm	Ft-lb	Nm	Ft-lb
CL 10.9	M8 x 1.25	35	26	27	20
	M10 x 1.50	71	53	58	42
	M12 x 1.75	124	92	101	73
	M14 x 1.50	200	148	163	118
	M14 x 2.00	200	148	163	118
	M16 x 2.00	311	230	254	184
	M20 x 1.50	610	450	498	360
	M20 x 2.50	608	449	497	359
	M24 x 3.00	1054	778	861	622
	M27 x 3.00	1543	1138	1260	910
	M30 x 3.50	2095	1545	1712	1236
	M36 x 4.00	3659	2699	2991	2159
8	1/4-20	14	11	11	8
	5/16-18	32	24	26	19
	3/8-16	59	44	48	35
	7/16-14	94	70	77	56
	1/2-13	143	106	116	84
	1/2-20	162	120	133	96
	5/8-11	287	212	234	169
	3/4-10	509	376	415	300
	7/8-9	821	606	670	484
	1.00-8	1232	909	1007	727
	1.00-14	1383	1020	1130	816
	1.25-7	2463	1817	2013	1453
8/L9	1.50-6	4287	3162	3504	2529

Wet Torque Values					
		Hex/Socket Head		Flat Head	
					
Fastener Grade	Size x Pitch	Nm	Ft-lb	Nm	Ft-lb
CL 10.9	M8 x 1.25	29	22	23	17
	M10 x 1.50	61	45	49	36
	M12 x 1.75	105	78	85	62
	M14 x 1.50	150	111	121	88
	M14 x 2.00	170	126	138	100
	M16 x 2.00	265	196	216	156
	M20 x 1.50	456	337	372	269
	M20 x 2.50	517	382	422	305
	M24 x 3.00	894	660	731	528
	M27 x 3.00	1312	968	1072	774
	M30 x 3.50	1779	1312	1453	1049
	M36 x 4.00	3110	2294	2542	1835
8	1/4-20	13	10	11	8
	5/16-18	27	20	22	16
	3/8-16	50	37	40	29
	7/16-14	80	59	65	47
	1/2-13	122	90	99	72
	1/2-20	138	102	112	81
	5/8-11	244	180	199	144
	3/4-10	433	320	354	256
	7/8-9	698	515	570	412
	1.00-8	1046	772	854	617
	1.00-14	1175	867	960	693
	1.25-7	2095	1545	1712	1236
8/L9	1.50-6	3644	2688	2979	2150

O-RING BOSS & FLAT FACE O-RING TORQUE SPECIFICATIONS

O-Ring Boss Torque Values		
Size Dash	Nm	Ft-lb
-4	22	16
-5	27	20
-6	36	26
-8	83	60
-10	110	80
-12	187	135
-14	249	180
-16	304	220
-20	387	280
-24	498	360

Flat Face O-Ring Torque Values		
Size Dash	Nm	Ft-lb
-4	18	13
-6	30	22
-8	60	44
-10	85	62
-12	121	88
-14	121	88
-16	160	116
-20	213	154
-24	274	198

BOLT DRIVE SPECIFICATIONS

Thread Size x Pitch	Hex Head	Socket Head	Flat Head
			
Wrench/Drive Size			
M8 x 1.25	13mm	6mm	5mm
M10 x 1.50	17mm	8mm	6mm
M12 x 1.75	19mm	10mm	8mm
M14 x 1.50	22mm	12mm	10mm
M14 x 2.00	22mm	12mm	10mm
M16 x 2.00	24mm	14mm	10mm
M20 x 1.50	30mm	17mm	12mm
M20 x 2.50	30mm	17mm	12mm
M24 x 3.00	36mm	19mm	14mm
M27 x 3.00	41mm	19mm	-
M30 x 3.50	46mm	22mm	-
M36 x 4.00	55mm	27mm	-
1/4-20	7/16"	3/16"	5/32"
5/16-18	1/2"	1/4"	3/16"
3/8-16	9/16"	5/16"	7/32"
7/16-14	5/8"	3/8"	1/4"
1/2-13	3/4"	3/8"	5/16"
1/2-20	3/4"	3/8"	5/16"
5/8-11	15/16"	1/2"	3/8"
3/4-10	1-1/8"	5/8"	1/2"
7/8-9	1-5/16"	3/4"	9/16"
1.00-8	1-1/2"	3/4"	5/8"
1.00-14	1-1/2"	3/4"	5/8"
1.25-7	1-7/8"	7/8"	7/8"
1.50-6	2-1/4"	1"	1"



GENESIS®

The Promise of Performance.

CONTACT INFORMATION

Genesis Attachments

1000 Genesis Drive
Superior, WI 54880 USA

Toll Free: 888-SHEAR-IT
(888-743-2748)

Phone: 715.395.5252

E-mail:
info@genesisattachments.com

Europe/Africa/Middle East Genesis GmbH

Teramostrasse 23
87700 Memmingen, Germany

Phone: +49 83 31 9 25 98 0

Fax: +49 83 31 9 25 98 80

genesis-europe.com

E-mail:
info@genesis-europe.com

Asia Pacific Representative Office

24 Upper Serangoon View #12-28
Singapore 534205

Phone: +65 9673 9730

E-mail:
tchoo@genesisattachments.com

Central America & Colombia

Cra 13A #89-38 / Ofi 613
Bogota, Colombia

Phone: +57 1 610 8160 / 795 8747

E-mail:
contact@themsagroup.com

View and download all manuals: genesisattachments.com/manuals
Patents: genesisattachments.com/products/patents