



# Razer Demolition Tool (GDT)

## SAFETY & OPERATOR'S MANUAL



## CONTACT INFORMATION

### Genesis Attachments

1000 Genesis Drive  
Superior, WI 54880 USA

Toll Free: 888-SHEAR-IT  
(888-743-2748)

Phone: 715.395.5252

E-mail:  
info@genesisattachments.com

### Europe/Africa/Middle East Genesis GmbH

Teramostrasse 23  
87700 Memmingen, Germany

Phone: +49 83 31 9 25 98 0  
Fax: +49 83 31 9 25 98 80  
genesis-europe.com

E-mail:  
info@genesis-europe.com

### Asia Pacific Representative Office

24 Upper Serangoon View #12-28  
Singapore 534205

Phone: +65 9673 9730

E-mail:  
tchoo@genesisattachments.com

### Central America & Colombia

Cra 13A #89-38 / Ofi 613  
Bogota, Colombia

Phone: +57 1 610 8160 / 795 8747

E-mail:  
contact@themsagroup.com

View and download all manuals: [genesisattachments.com/manuals](http://genesisattachments.com/manuals)  
Patents: [genesisattachments.com/products/patents](http://genesisattachments.com/products/patents)

## PREFACE

To ensure years of safe, dependable service, only trained and authorized persons should operate and service your Genesis attachment. It is the responsibility of the product's owner to ensure the operator is trained in the safe operation of the product and has available this manual for review. It is the responsibility of the operator and maintenance personnel to read, fully understand and follow all operational and safety-related instructions in this manual. The attachment should not be operated until you have read and fully understand these instructions. Always use good safety practices to protect yourself and those around you.

### **Important**

This operator's manual must accompany the attachment at all times and be readily available to the operator.

### **Manual Replacement**

Should this manual become damaged or lost or if additional copies are required, immediately contact any authorized Genesis dealer or the Genesis Service Department at 888-743-2748 or 715-395-5252 for a replacement.

### **Registration Form**

The Warranty Registration Form must be filled out by the dealer or customer and returned to Genesis indicating the date the attachment went into service.

### **Possible Variations**

Genesis cannot anticipate every possible circumstance that might involve a potential hazard as the owner's requirements and equipment may vary. Therefore, the warnings in this publication and on the product may not be all-inclusive, and you must satisfy yourself that the procedure, application, work method or operating technique is safe for you and others before operating.

### **Public Notice**

Genesis reserves the right to make changes and improvements to its products and technical literature at any time without public notice or obligation. Genesis also reserves the right to discontinue manufacturing any product at its discretion at any time.

### **Warranty**

All work or repairs to be considered for warranty reimbursement must be pre-authorized by the Genesis Service Department. Any alterations, modifications or repairs performed before authorization by the Genesis Service Department will render all warranty reimbursement consideration null and void without exception. See page 47 for Warranty Claim Procedures.

Improper operation or improperly performed maintenance may render any warranty null and void.

# TABLE OF CONTENTS

<b>CONTACT INFORMATION</b> .....	<b>2</b>
<b>PREFACE</b> .....	<b>3</b>
Important.....	3
Manual Replacement.....	3
Registration Form.....	3
Possible Variations.....	3
Public Notice.....	3
Warranty.....	3
<b>SAFETY STATEMENTS</b> .....	<b>7</b>
<b>OPERATIONAL SAFETY</b> .....	<b>8</b>
Read Manual Before Operating or Maintaining the Attachment.....	8
Personal Protection.....	8
Know Your Equipment.....	8
Before Operating.....	8
Check the Equipment.....	9
Stability.....	9
Know the Work Area.....	10
Starting Procedure.....	10
Place the Load Safely.....	10
Safely Operate Equipment.....	11
Transporting the Attachment.....	12
Equipment Condition.....	12
Working Overhead.....	12
Power Lines.....	12
Use Care with Hydraulic Fluid Pressure.....	13
Prioritized Oil Flow.....	14
Emergency Situations.....	14
Unsafe Conditions.....	14
Crystalline Silica Dust.....	14
Prop. 65 Warning for California Residents.....	14
Process Material Safely.....	15
Lift the Load Safely.....	15
Place the Load Safely.....	15
<b>ATTACHMENT MARKINGS</b> .....	<b>16</b>
<b>TRANSPORT ROTATION LOCK</b> .....	<b>17</b>
<b>ATTACHMENT INSTALLATION</b> .....	<b>18</b>
<b>ROTATOR INSTALLATION</b> .....	<b>19</b>
Foot Switch Installation.....	19
Rotation Circuit - Gear Pump Type.....	20
Rotation Circuit - Auxiliary Valve on Machine.....	21
<b>HYDRAULIC START-UP</b> .....	<b>22</b>
Start-up Procedure.....	22
<b>GENERAL OPERATION INSTRUCTIONS</b> .....	<b>23</b>
Start-up.....	23
Efficient and Productive Operation.....	23

# TABLE OF CONTENTS

<b>COMMON OPERATIONAL CONCERNS</b>	<b>24</b>
Cutting Larger Materials	24
Chatter While Cutting	24
<b>MAINTENANCE SAFETY</b>	<b>25</b>
<b>MAINTENANCE SCHEDULE</b>	<b>27</b>
Four-Hour Checklist	27
Eight-Hour Checklist	27
Long-term Maintenance	27
<b>LUBRICATION POINTS</b>	<b>28</b>
<b>BOLT TORQUE SPECS</b>	<b>29</b>
<b>TOOTH AND BLADE MAINTENANCE</b>	<b>30</b>
Pulverizing Teeth	30
Hard-Surfacing Teeth	31
Cutting Blades	32
Blade Removal	32
Blade Rotation	32
Blade Gap	33
Blade Gap Measuring Procedure	33
Shimming Procedure	33
<b>GENERAL WELDING GUIDELINES</b>	<b>34</b>
Welding Ground Clamp	34
Welding Rules	34
<b>BUILD-UP AND HARD-SURFACING</b>	<b>35</b>
Hard-Surfacing Patterns	35
<b>HARD-SURFACING</b>	<b>36</b>
<b>HYDRAULIC/ROTATION MAINTENANCE</b>	<b>37</b>
Hydraulic Requirements	37
Rotation Valve Settings	37
GenFlow Regeneration Valve	38
Regeneration Valve Adjustment	38
<b>GENFLOW REGENERATION VALVE - HOW IT WORKS</b>	<b>39</b>
<b>GENFLOW REGENERATION VALVE</b>	<b>40</b>
GDT 190 & 290	40
GDT 390	40
GDT 590 & 890	41
<b>SLEWING RING MAINTENANCE</b>	<b>42</b>
<b>ROTATION CIRCUIT</b>	<b>43</b>
Rotation with Motion Control Valve	43
<b>TROUBLE-SHOOTING GUIDE</b>	<b>44</b>
<b>WARRANTY</b>	<b>47</b>
Claim Procedure	47
Blade Warranty	47

# TABLE OF CONTENTS

- PARTS ORDER POLICY AND PROCEDURE** ..... **48**
- Parts Orders Should Include..... 48
- Placing Orders..... 48
- Part Numbers..... 48
- Shipping..... 48
- Invoices..... 48
- Returns..... 48
- Warranty Returns..... 48
- PARTS ORDER FORM** ..... **49**
- CONTACT INFORMATION** ..... **50**

NOTICE

For bolt torque specs, see the Genesis Fastener Manual.  
[genesisattachments.com/manuals](https://genesisattachments.com/manuals)

## SAFETY STATEMENTS



This symbol by itself or used with a safety signal word throughout this manual is used to call attention to instructions involving your personal safety or the safety of others. Failure to follow these instructions can result in injury or death.



This statement is used where serious injury or death will result if the instructions are not followed properly.



This statement is used where serious injury or death could result if the instructions are not followed properly.



This statement is used where minor or moderate injury could result if the instructions are not followed properly.

**NOTICE**

This statement is used where property damage could result if the instructions are not followed properly.

# OPERATIONAL SAFETY

## Read Manual Before Operating or Maintaining the Attachment



Read this manual before attempting to operate the attachment. This operator's manual should be regarded as part of the attachment. For proper installation, operation and maintenance of the attachment, operators and maintenance personnel must read this manual.



## **WARNING**

Serious injury or death could result if appropriate protective clothing and safety devices are not used.

## Personal Protection

Use protective clothing and safety devices appropriate for the working conditions. These may include but are not limited to:

- ✓ Hard hat
- ✓ Safety glasses, goggles or face shield
- ✓ Hearing protection
- ✓ Safety shoes
- ✓ Heavy gloves
- ✓ Reflective clothing
- ✓ Respirator or filter mask



# Safety matters

## Know Your Equipment



Know your attachment's capabilities, dimensions and functions before operating. Inspect your attachment before operating and never operate an attachment that is not in proper working order. Remove and replace any damaged or worn parts.

## Before Operating

- ✓ Warn all others in the area that you are about to start operation.
- ✓ Perform the Check the Equipment steps outlined in this manual.
- ✓ Check underneath and around the machine. Make sure all personnel and equipment are clear from the area of operation and equipment movement. Check clearances in all directions, including overhead.
- ✓ Be properly seated in the operator's seat.
- ✓ Do not attempt to operate until you have read and fully understand this manual and the OEM manual for the carrier.

# OPERATIONAL SAFETY

## Check the Equipment

Before use, check the equipment to ensure it is in good operating condition.

Check the following:

- ✓ Grease fittings. Pump grease at all fitting locations, see page 28.
- ✓ Hydraulic fluid level. Add hydraulic fluid as required.
- ✓ Hydraulic hoses and hose connections for wear or leaks. Repair or replace any damaged hoses or connections.
- ✓ All control levers for proper operation.
- ✓ Rotation bearing. Visually check for loose or damaged bolts. If repair is required, refer to qualified personnel.
- ✓ Grease rotation bearing and pinion gear.
- ✓ Check for loose or missing pin retaining bolts.
- ✓ Check cylinders for dents (barrel) or dings (rod).



**GOOD  
CONDITION**



**WARNING**

Serious injury or death could result if warnings or instructions regarding carrier stability and the work area are not followed properly.

## Stability

Your Genesis attachment is sized for carrier stability. However, improper operation, faulty maintenance or unauthorized modifications may cause instability.

- ✓ Know the working ranges and capacities of the carrier to avoid tipping.
- ✓ Use the recommended carrier counter weight.

The following conditions affect stability:

- Ground conditions
- Grade
- Weight of attachment
- Contents of attachment
- Operator judgement



For greater stability, knuckle the attachment to bring the load closer to the center of rotation (center of gravity) while lifting. Use extra caution during reaching to avoid tipping.

## OPERATIONAL SAFETY

### **Know the Work Area**

Check clearances in the work area. Keep all bystanders at a safe distance. Do not work under obstacles. Always check your location for overhead and buried power lines or other utilities before operation.

Check ground conditions. Avoid unstable or slippery areas. Position the carrier on firm level ground. If level ground is not possible, position the carrier to use the attachment to the front or back of the carrier. Avoid working over the side of the carrier.

To reduce the risk of tipping and slipping, never park on a grade exceeding 10% (one-foot rise over the span of a ten-foot run).

### **Starting Procedure**

Before operating, walk completely around the equipment to make certain no one is under it, on it or close to it. Keep all bystanders at least 75 feet away from the area of operation and equipment movement. Let all other workers and bystanders know you are preparing to start. DO NOT operate until everyone is clear.

Always be properly seated in the operator's seat before operating any carrier controls.

#### **To start:**

- ✓ Make sure all controls are in the center (neutral) position.
- ✓ Be properly seated.
- ✓ Slowly operate all functions to check for proper operation and to bleed air from the hydraulic system.

#### **To shut down:**

- ✓ Return your Genesis attachment to a rest position on the ground.
- ✓ Shut off the carrier engine.
- ✓ Work controls in all directions to relieve hydraulic pressure, per excavator manufacturer's instructions.



## **WARNING**

Serious injury or death could result if warnings or instructions regarding safe operation are not followed properly.

### **Place the Load Safely**

Do not move the attachment, or anything held in the jaws, over people, equipment or buildings. Do not throw or drop the contents. Operate the controls smoothly and gradually.

# OPERATIONAL SAFETY

## Safely Operate Equipment

Do not operate equipment until you are trained by a qualified operator in its use and capabilities.

See your carrier's manual for these instructions.

- ✓ Operate only from the operator's seat. Check the seat belt daily and replace if frayed or damaged.
- ✓ Do not operate this or any other equipment under the influence of drugs or alcohol. If you are taking prescription medication or over-the-counter drugs ask your medical provider whether you can safely operate equipment.
- ✓ Never leave equipment unattended with the engine running or with the attachment in a raised position. Apply the brakes before exiting the equipment.
- ✓ Do not exceed the lifting capacity of your carrier.
- ✓ Avoid conditions that can lead to tipping. The carrier can tip when operated on hills, ridges, banks and slopes. Avoid operating across a slope which could cause the carrier to overturn.
- ✓ Reduce speed when driving over rough terrain, on a slope, or when turning to avoid overturning the carrier.
- ✓ Never use the attachment as a work platform or personnel carrier.
- ✓ Keep all step plates, grab bars, pedals and controls free of dirt, grease, debris and oil.
- ✓ Never allow anyone to be around the equipment when it is operating.
- ✓ Do not operate poorly maintained or otherwise faulty equipment. Inform the proper authority and DO NOT resume operation until the problem has been fixed.
- ✓ Do not alter or remove any safety features.
- ✓ Know your work site safety rules as well as traffic rules and flow. When in doubt on any safety issue, contact your supervisor or safety coordinator for an explanation.
- ✓ A heavy load can cause equipment instability. Use extreme care during travel. Slow down on turns and watch out for bumps. The equipment may need additional counter-weights to counterbalance the weight of the attachment.



# OPERATIONAL SAFETY

## Transporting the Attachment

- ✓ Travel only with the attachment in a safe transport position to prevent uncontrolled movement. Drive slowly over rough ground and on slopes.
- ✓ When driving on public roads use safety lights, reflectors, Slow Moving Vehicle signs, etc., to prevent accidents. Check local government regulations that may affect you.
- ✓ Do not drive close to ditches, excavations, etc., as cave-in could result.
- ✓ Do not smoke when refueling the prime mover. Allow room in the fuel tank for expansion. Wipe up any spilled fuel. Secure cap tightly when done.

## Equipment Condition

Never operate poorly maintained equipment. When maintenance is required, repair or replace parts immediately.



**WARNING**

Serious injury or death could result if warnings or instructions regarding working overhead are not followed properly.

## Working Overhead

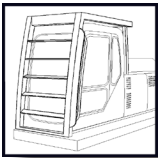

Avoid handling material overhead whenever possible. Safety glass and wire mesh cab guarding must be installed to protect the operator from flying debris that may be created during handling. Falling Object Protection Structures, or FOPS, are necessary for any application where material is to be handled overhead.



**DANGER**

Serious injury or death will result if warnings or instructions regarding power lines are not followed properly.

## Power Lines

Do not operate the machine near energized power lines. All local, state/provincial and federal regulations must be met before approaching power lines, overhead or underground cables, or power sources of any kind with any part of the carrier or attachment. Always contact the appropriate utility when operating near power lines. The lines should be moved, insulated, disconnected or de-energized and grounded before operating in the area.



Current in high voltage lines may arc some distance from the wire to a nearby ground. Keep all parts of the machine at least 50 feet (16m) away from power lines.

## OPERATIONAL SAFETY



### WARNING

Serious injury or death could result if warnings or instructions regarding hydraulic fluid pressure are not followed properly.

#### Use Care with Hydraulic Fluid Pressure

Hydraulic fluid under pressure can penetrate the skin and cause serious injury or death. Hydraulic leaks under pressure may not be visible.

- ✓ Keep unprotected body parts, such as face, eyes and arms as far away as possible from a suspected leak. Flesh injected with hydraulic fluid may develop gangrene or other permanent injuries.
- ✓ If injured by injected fluid see a doctor immediately.
- ✓ Wear safety glasses and protective clothing and use a piece of cardboard or wood when searching for hydraulic leaks.

**Do Not Use Your Hands!**  
**See illustration below.**

- ✓ Hydraulic oil becomes hot during operation. Do not let hydraulic oil or components contact skin, as it could cause severe burns. Allow hydraulic components to cool before working on them. Use appropriate protective clothing and safety equipment. If burned, seek immediate medical attention.

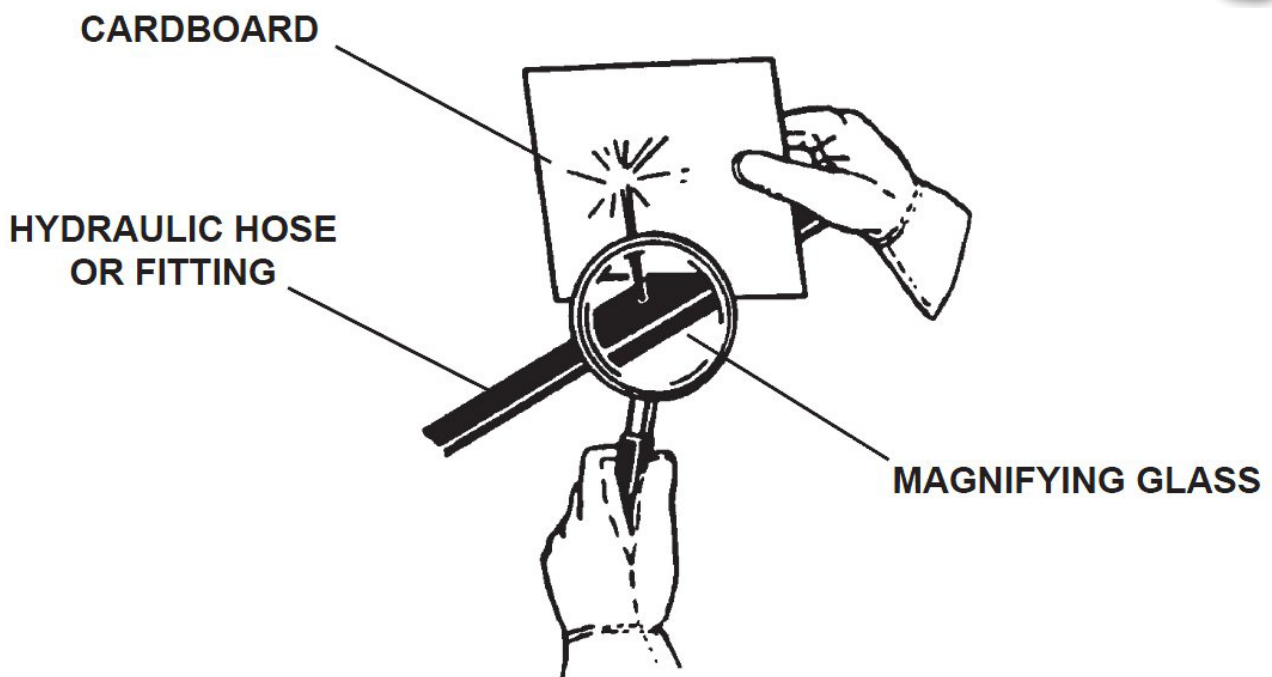

## OPERATIONAL SAFETY

### Prioritized Oil Flow

Equipment operators must ensure there is prioritized oil flow to the main valves in overhead operations or high reach conditions.

### Emergency Situations

Always be prepared for emergencies. Make sure a fire extinguisher is available. Be familiar with its operation. Make sure to inspect and service the fire extinguisher regularly. Make sure a first aid kit is readily available.



### Unsafe Conditions

Do not operate if an unsafe condition exists. Stop operation immediately, shut down the machine and report the unsafe condition to the proper authority. Equipment operation and maintenance practices directly affect your safety and the safety of those around you. Always use common sense while operating and be alert to unsafe conditions.

### Crystalline Silica Dust

It is recommended to use dust suppression, dust collection and if necessary, personal protective equipment during the operation of any attachment that may cause high levels of dust.



**DANGER**

Exposure to respirable crystalline silica dust along with other hazardous dusts may cause serious or fatal respiratory disease.

**IMPORTANT:** Concrete and masonry products contain silica sand. Quartz, which is a form of silica and the most common mineral in the Earth's crust, is associated with many types of rock.

Some activities that may have silica dust present in the air include demolition, sweeping, loading, sawing, hammering, drilling or planing of rock, concrete or masonry.

It is recommended to use dust suppression (such as water) or dust collection (such as a vacuum) along with personal protective equipment if necessary during the operation of any attachment that may cause high levels of silica dust.



### Prop. 65 Warning for California Residents



**WARNING**

This product may contain chemicals known to the State of California to cause cancer, birth defects, or other reproductive harm. For more information visit: [P65Warnings.ca.gov](http://P65Warnings.ca.gov)

## OPERATIONAL SAFETY



### **WARNING**

Using your Genesis attachment in unauthorized applications may create an unsafe situation and will void the warranty.

### **Process Material Safely**

- Do not process hardened steel material such as tool steel, railroad rail, axles, springs, machined parts or high-strength material. Hardened/high-strength material breaks, rather than shears, which may cause flying debris. It will also cause damaging decompression spikes to your Genesis attachment and base carrier hydraulic systems.
- Do not operate any functions of the carrier while cutting or crushing with your attachment, including boom and drive functions.
- Do not pull down structures with your Genesis attachment. Doing so may cause falling debris or material to break free and exceed the capacities of the carrier, causing a tipping hazard and rotation component failures.
- Do not use rotation to pry or break material. Doing so exerts high back-driving forces and spikes to the rotation circuit components that cannot be cushioned hydraulically. It may also cause motor and gearbox failures. The rotator should only be used for positioning an attachment.
- Do not process pressurized containers unless the main valve has been removed and you are absolutely certain the container is empty.
- Do not process spring loaded brake chambers and automotive struts as the release of compressed springs is extremely dangerous. Nothing made of spring material or containing springs should be processed.

### **Lift the Load Safely**

- The hydraulic system has been preset and tested by your dealer. Do not alter hydraulic settings without consulting an authorized Genesis dealer or the Genesis Service Department. Doing so will void the warranty and may cause structural damage, accidents or tipping.
- Make sure the load is held securely in the jaws. Do not move a loaded attachment if load is loose or dangling. Make sure the load is pinched between the jaws – never cradle a load.
- For greater stability, knuckle the attachment to bring the load closer to the center of rotation (center of gravity) while lifting. Use extra caution during reaching to avoid tipping.

### **Place the Load Safely**

- Do not move the attachment, or anything held in the jaws, over people, equipment or buildings. Place the load gently. Do not throw or drop the contents.
- Operate the controls smoothly and gradually. Jerky controls are hazardous and may cause damage to the carrier.
- Avoid fire hazards. Keep the area clean. Remove all flammable materials from the area during any welding or heating process. Have a fire extinguisher nearby and know how to use it.
- Never substitute pins or bolts. Use factory supplied pins. Replace all bolts with the same size and grade. Failure to do so may cause serious injury or death.
- Use your Genesis attachment only as directed in this manual. Do not use the attachment to lift and move other objects. Doing so may cause instability and tipping.

## ATTACHMENT MARKINGS

Decals are necessary for safe operation and maintenance. To reorder, contact your Genesis dealer or call 715-395-5252.

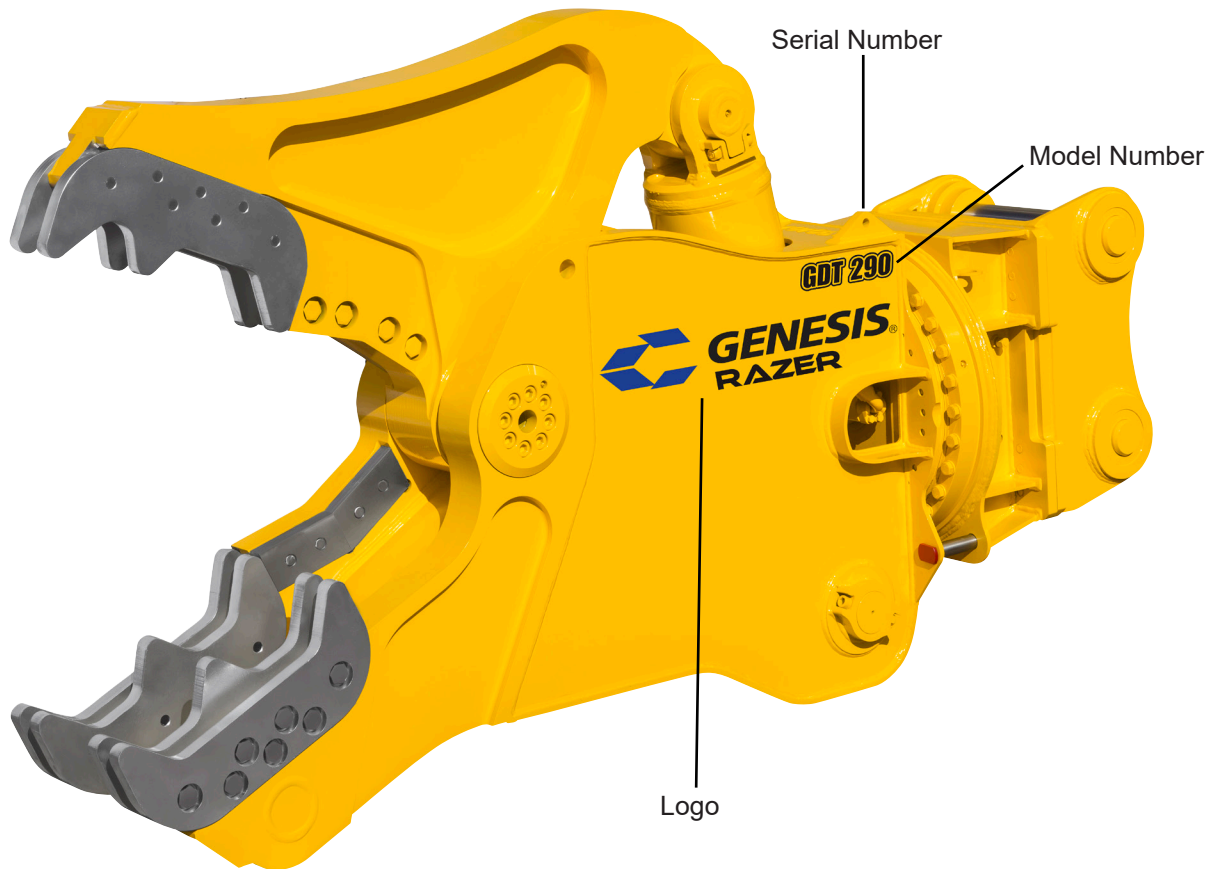

## TRANSPORT ROTATION LOCK

Your GDT may be equipped with one of two rotation lock systems.

Rotation (transport) locks are installed at the factory to allow the bracket to be shipped with the mounting pins facing upward. This is beneficial to the end user when removing the attachment from the truck and mounting it to the excavator.

**Rotation locks MUST be removed before operating the attachment to prevent rotation system damage.**

Tools equipped with transport lock pins:

Must be in **Stowed Position**  
for normal operation

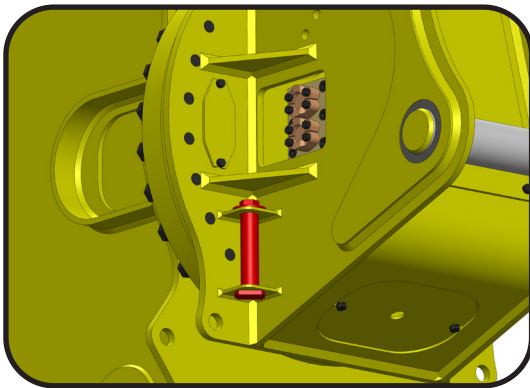

**Locked Position**  
for transportation only

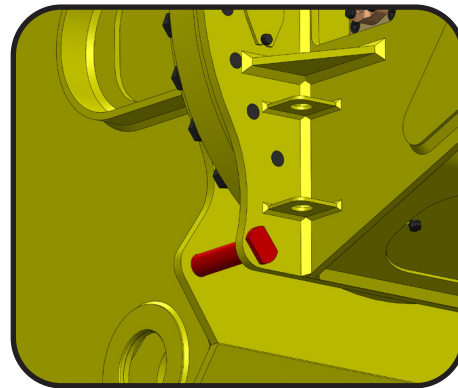

Tools equipped with slewing ring transport lock blocks:

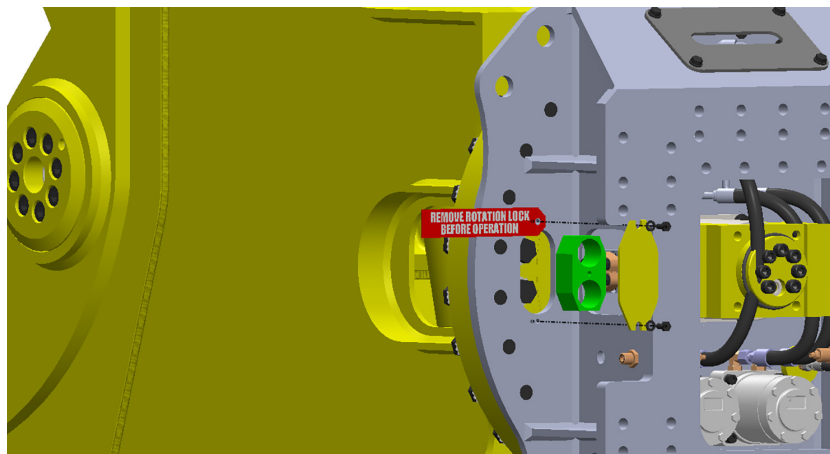

The rotation locks are located inside the small bolt covers for the slewing ring and marked with a red flag labeled "REMOVE ROTATION LOCK BEFORE OPERATION". The cover bolt can be threaded into the rotation lock for removal.

There are TWO locks in every attachment, one on either side of the bracket. In some cases, one of the port blocks may need to be removed to access the rotation lock. The rotation locks and red flags should be saved for use during future transportation.

## ATTACHMENT INSTALLATION



Be sure hydraulic pressure is relieved before disconnecting hydraulic fittings. Remove necessary fittings SLOWLY.

The attachment is usually shipped in an upright position. Extreme care must be used when inverting the attachment for installation.

Follow the excavator OEM's removal and safety instructions to remove the bucket or other stick attachments.

Position the attachment upside down on flat, solid ground. Blocking may be required to raise the mounting bracket into proper position.

Track the excavator to the attachment with the jaws facing the operator. Lift the excavator stick over the attachment, carefully positioning the stick tip connection with the attachment mounting main pivot bore. Pin the excavator stick to the attachment.

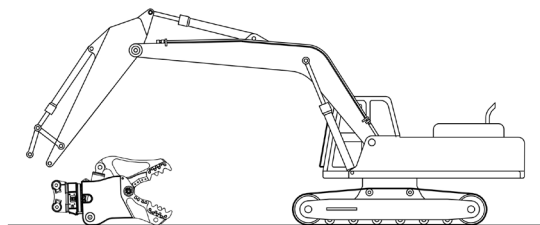

Slowly raise the boom to lift the attachment, allowing the cylinder pivot connection to come within range of the excavator cylinder stroke.

Extend the excavator cylinder until the power link bore lines up with the cylinder pivot connection. Pin the excavator cylinder to the attachment.

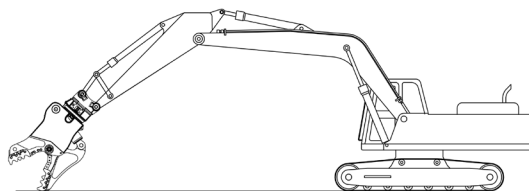

Crowd and extend the attachment, checking closely to make sure there is no interference between the bracket and hard lines. Also check for interference between the cylinder and boom/stick.

Install excavator hydraulic hoses, supply and return, from the stick tip to the attachment manifold blocks.

The stick and bucket circuits are oriented as to rod and bore sides of their respective cylinders. Be sure to connect rod-to-rod and bore-to-bore when connecting a circuit to the attachment. When these are reversed, extra pressure is needed to open the jaw, which pulls down the engine, de-strokes the pumps, increases jaw cycle time, creates high oil temperature and burns more fuel.

The attachment must be vertical before putting oil into it or an air lock in the regen valve may prevent the jaw from opening.

**Note: Genesis' standard pin material is Induction Hardened Chrome (IHC), which is to be used for all direct pin 2<sup>nd</sup> and 3<sup>rd</sup> member mounting. To avoid risk of pin failure when using a pin grabbing coupler, the standard IHC pins must be replaced with a heat-treated pin material from Genesis.**

## ROTATOR INSTALLATION

The rotator requires a 1/2" minimum case-drain line with a minimum working pressure rating of 250 PSI. **Run the case-drain line from the rotation head of the attachment to a dedicated filter on the excavator, plumbed directly into the main section of the hydraulic tank. Do not plumb to the return side of the tank.**

The maximum case-drain pressure measured at the motor while attempting to rotate the attachment stalled on the ground is 40 PSI. Case-drain pressures will rise during cold weather operation.

Use the correct fittings. Secure the case-drain line to the excavator stick.

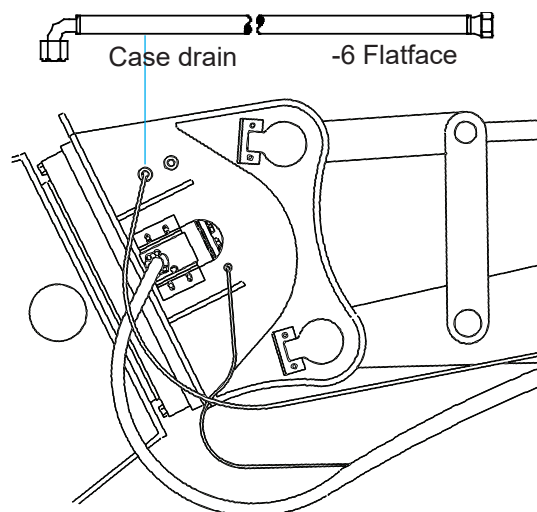

### NOTICE

**Do not plumb the case-drain into the main return system or into any other existing case drain or return circuit. Plumb only to the hydraulic tank.**

### Foot Switch Installation

Install the foot switch in the excavator and connect with electrical harness.

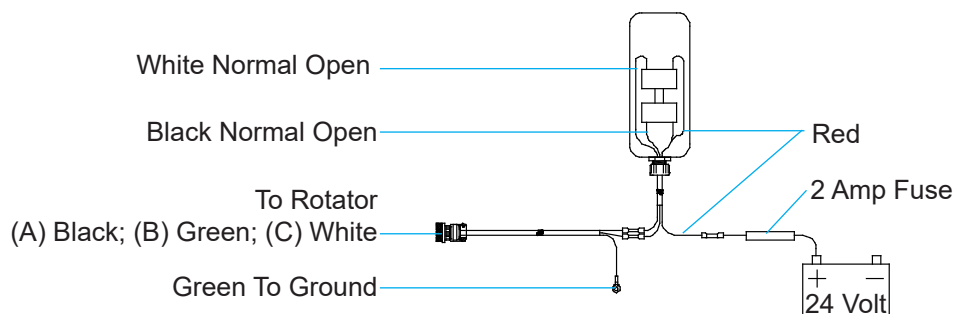

The rotator requires an additional hydraulic circuit. One of the several available options has been supplied with the attachment. These diagrams show the installation of the additional circuit. Refer to the Hydraulic/Rotation Maintenance section of this manual for valve descriptions, functions and settings.

# ROTATOR INSTALLATION

## Rotation Circuit - Gear Pump Type

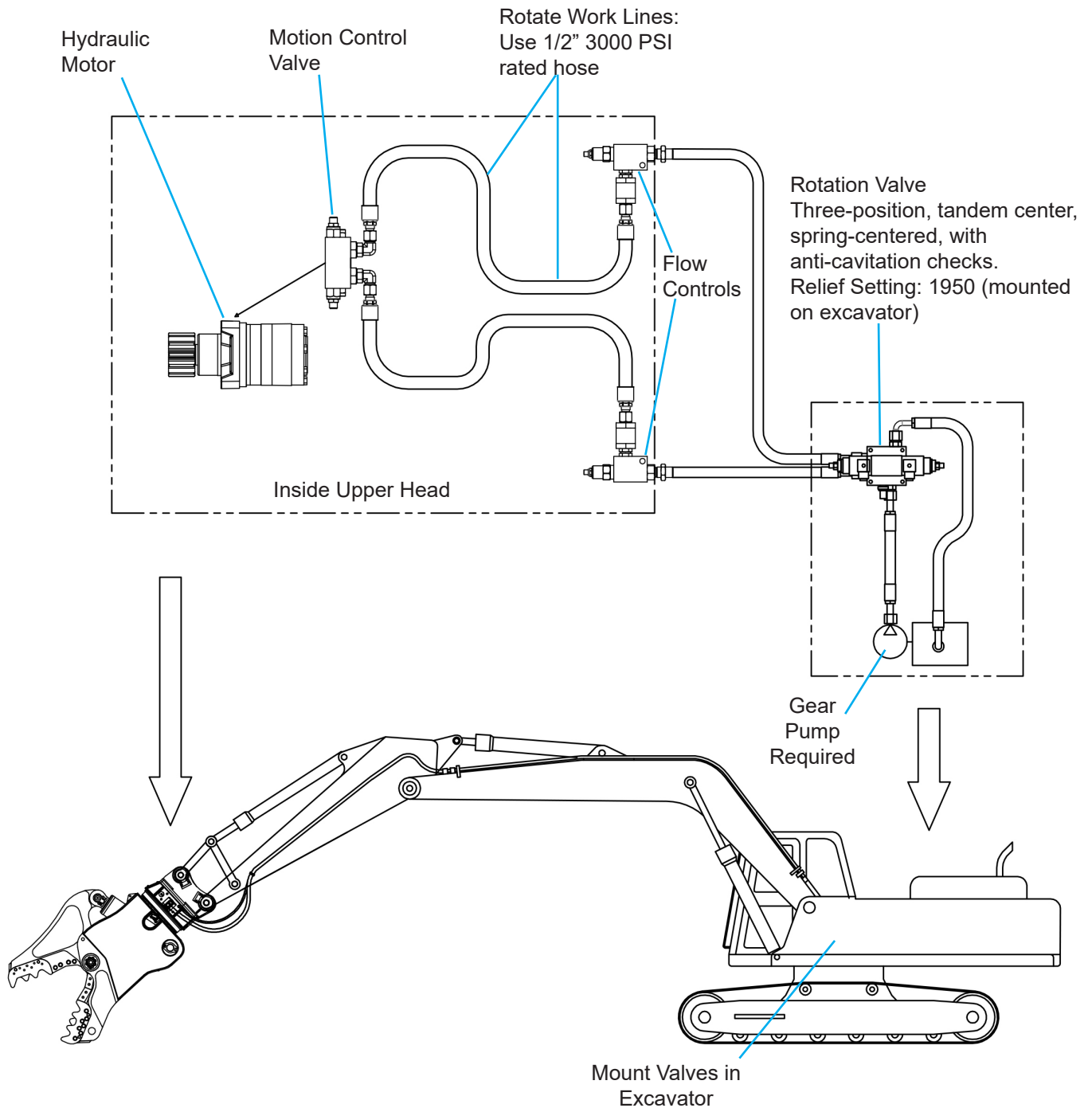

# ROTATOR INSTALLATION

## Rotation Circuit - Auxiliary Valve on Machine

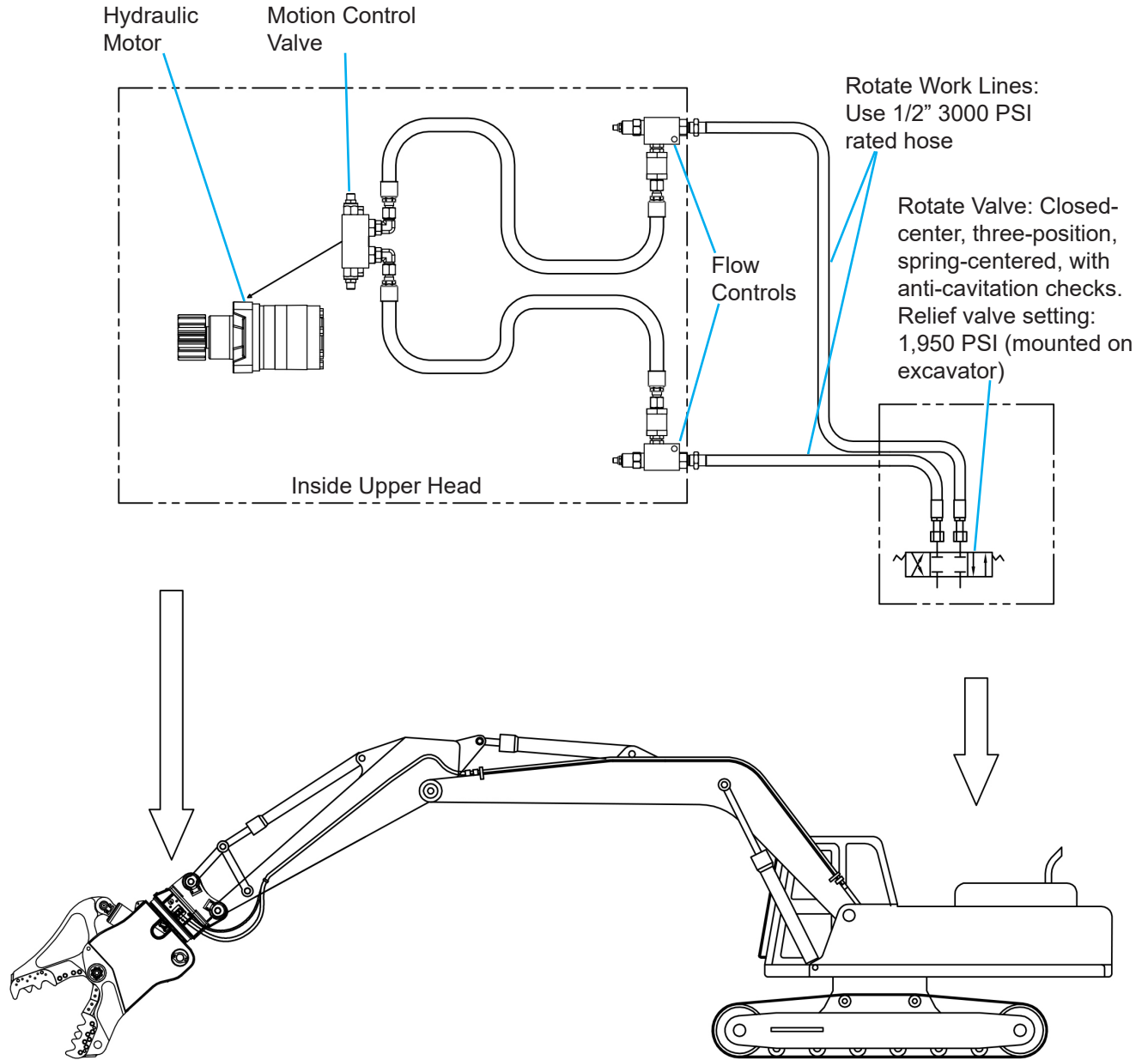

## HYDRAULIC START-UP

Genesis attachments are designed to operate under full excavator pressure or up to 5500 PSI. Due to these high pressures, it is important that air is bled from the attachment cylinder after installation. Failure to follow these procedures could result in cylinder seal damage and/or excavator hydraulic system damage.

### Start-up Procedure

- ✓ Check the excavator hydraulic tank for proper fluid level.
- ✓ Excavator oil should be warmed up before hooking up attachment lines in cold weather. If oil is cold, air from the cylinder will be pushed into the oil tank, causing oil to foam. This problem takes hours to correct, and it may cause pump cavitation.
- ✓ Follow the OEM procedures for starting and warming the excavator hydraulic system. Do not operate the attachment circuit during the warm-up period.
- ✓ After the excavator has reached normal operating temperature, set the engine to idle speed.
- ✓ The attachment must be vertical. Do not allow the tank to run low - have someone watch the oil gauge.
- ✓ Slowly fill the bore end of the attachment cylinder to partially close the jaws.

### **NOTICE**

Do not fully extend or retract attachment cylinder with the first cycles.

Slowly fill the rod end of the attachment cylinder to open the jaws. Use partial strokes extending and retracting, slowly working to full strokes.

Stop and check the excavator hydraulic fluid level again to be sure there is still sufficient fluid. Service as required. Note: hydraulic fluid level should be checked with the attachment jaws open (cylinder retracted).

Cycle the attachment jaws five or six strokes before increasing to full operating pressure.

## GENERAL OPERATION INSTRUCTIONS

Follow all rules and procedures outlined in the Operation Safety section under General Safety in this manual.

Use the attachment only as intended, in approved applications, as set forth in this manual.

Do not allow attachment, exposed cylinder rod or hoses to come into contact with any obstacles, buildings or the excavator.

The attachment is not intended to crush or break objects or structures by swinging or dropping the attachment.

### **Start-up**

During initial operation and any time jaw maintenance has been performed, process thin and lighter material first to work-harden wear areas, developing a harder, more durable edge.

## **NOTICE**

When operating in temperatures below freezing, it is also important to process light materials first. This allows the attachment's structural material to warm up, preventing thermal cracking.

### **Efficient and Productive Operation**

Operators should become accustomed to performing work in the most proficient manner possible.

Material processing areas should be as close as safely possible to the location for loading materials for transportation. Less time spent processing, loading and transporting materials greatly affects operational costs and productivity and dramatically reduces man hours, fuel costs and wear on equipment.

Operators should develop the habit of assessing materials to be processed and visualizing a starting and finishing point to avoid unnecessary cutting/crushing. Excessive moving, positioning and handling cost time and money. Bringing the jaws to full open, when only partial jaw open is needed, wastes time and fuel, slows other excavator functions as well as causes needless wear to hydraulic components, hoses and o-rings. More efficient processing will extend the life of the attachment.

## COMMON OPERATIONAL CONCERNS

When working in a situation where debris may fall from above, rotate the attachment 180° so the stationary jaw is on top. This will prevent debris from falling into the body while the upper jaw is closed or closing.



### CAUTION

Keep debris from falling into the body of the attachment to prevent hydraulic component damage.

### **Cutting Larger Materials**

When processing larger materials the jaw stalls just before cutting/crushing.

Reposition the attachment so the material is as close to the throat as possible. Without pushing down on the material with excavator force, rapidly close the jaw on the material. Using the speed of regeneration can improve performance when processing larger materials.

### **Chatter While Cutting**

If the attachment starts to chatter while cutting, back out of the cut and reposition at a different spot.

Chattering is an indication that material is jamming between the upper and lower cutting blades. This indicates that blade maintenance needs to be performed immediately. Worn blades and improper blade gaps are usually the cause.

Most jamming conditions can be prevented if the operator pays attention to the sound and vibration that is associated with a jam. Remember that because of the rod-to-bore ratios of displacement on the attachment's hydraulic cylinder piston, the attachment has half the force on jaw open compared to jaw close. So if the attachment is jamming while closing, it won't have enough retract force to open.

## MAINTENANCE SAFETY

Only trained and authorized persons should perform maintenance on the attachment. To be qualified, you must understand the instructions in this manual, have training, and know the safety rules and regulations of the job site.

Do not alter the physical, mechanical or hydraulic operation of the attachment. Doing so may cause a dangerous situation for yourself and those around you and will void the warranty.

Do not attempt repairs you do not understand. If any questions arise regarding a safety or maintenance procedure, contact Genesis or your Genesis dealer.

Read this entire manual. All personnel must understand the maintenance and safety procedures.

Use factory authorized parts. The use of unauthorized parts may compromise safety, performance and durability of the attachment and may void the warranty.

Follow the daily checklist and maintenance schedules in this manual. Extreme conditions may dictate shorter maintenance intervals.

Do not exceed bolt torque specifications. See the Genesis Fastener Manual.

Do not weld on structural components without consulting Genesis. Doing so may cause structural failure and void the warranty.

Do not work on the attachment before ensuring it will not move. Completely lower the boom to the ground or a rest position and relieve hydraulic pressure.

Never operate poorly maintained equipment. When maintenance is required, repair or replace parts immediately.

Do not operate under unsafe conditions. If an unsafe condition arises during operation, immediately shut down the equipment and report the situation to the proper authority.

## MAINTENANCE SAFETY

Do not work on any hydraulic lines or components while they are pressurized. Escaping hydraulic fluid can penetrate the skin, causing serious injury or death. Relieve pressure before performing maintenance. Keep hands and body parts away from pin holes and nozzles, which eject fluids under high pressure. Use a piece of cardboard to search for leaks.



If fluid is injected into the skin, seek medical assistance immediately from a doctor familiar with this type of injury.

### NOTICE

See “Use Care with Hydraulic Fluid Pressure”, page 13

Hydraulic oil becomes hot during operation. Do not let hydraulic oil or components contact skin, as it could cause severe burns. Allow hydraulic components to cool before working on them. Use protective clothing and safety equipment.



Remove paint before welding or heating. Hazardous fumes/dust can be generated when paint is heated by welding, soldering or using a torch. Do all work outside or in a well ventilated area and dispose of paint and solvent properly.

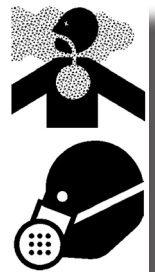

When sanding or grinding paint, avoid breathing the dust. Wear an approved respirator. If you use solvent or paint stripper, remove stripper with soap and water before welding. Remove solvent or paint stripper containers and other flammable materials from area. Allow fumes to disperse at least 15 minutes before welding or heating.

Avoid fire hazards. Keep the area clean. Remove all flammable materials from the area during any welding or heating process. Have a fire extinguisher nearby and know how to use it.



Never substitute pins or bolts. Use factory supplied pins. Replace all bolts with the same size and grade. Failure to do so may cause serious injury or death.

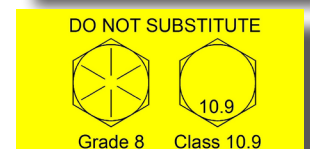

## MAINTENANCE SCHEDULE

Performing scheduled maintenance will promote safe, reliable operation of your attachment. Use maintenance procedures described in this manual. If you are not able to safely and competently perform these procedures, have a Genesis dealer perform them.

### NOTICE

Extreme operating conditions may require shortened maintenance intervals.

### Four-Hour Checklist

Inspect:

- Bolts - check for loose bolts, replace if damaged
- Fittings and hoses for damage or leaks
- Bracket pivot for wear and pin retainers
- Cylinder pivot for wear and pin retainers
- Entire attachment for cracks (visual check)

Grease:

- Attachment cylinder butt
- Attachment cylinder rod
- Main shaft/pivot, both sides

### Eight-Hour Checklist

Perform four-hour checklist plus the following:

Grease:

- Bracket pivot
- Bracket cylinder
- Rotation bearing (four locations)
- Rotation bearing gear teeth

Jaws, blades and teeth:

- Check blade tolerance
- Check blade edge radius
- Check for loose or excessively worn teeth
- Check for loose or damaged bolts, retorquing loose bolts when cool
- Build-up and hard-surface as required

See Blade Maintenance section in this manual regarding maximum tolerance and radius. See Jaw Maintenance section in this manual for build-up and hard-surfacing instructions.

### Long-term Maintenance

- Check all bolts, including slewing ring bolts, after the initial 80 hours of operation
- Replace slewing ring bolts every 2000 hours
- Replace regeneration valve components every 2 years or 4000 hours
- Reseal cylinder at 2 years or 4000 hours, whichever occurs first, the first time; 18 months or 3000 hours for all following reseals. In severe-duty applications or if operating the shear more than 10 hours per day, reduce these intervals.
- Reseal swivel every 2 years or at the time of cylinder resealing.

## LUBRICATION POINTS



Shut off excavator and disable hydraulics per OEM instructions before greasing.

For normal conditions above 32°F (0°C), use a lithium-based, premium grade 2 extreme-pressure grease. For temperatures below 32°F, use a grade 0 grease.

**Do not use grease containing Molybdenum (Moly).**

Genesis GLG-2<sup>®</sup> anti-wear, extreme-pressure lithium grease, PN 6302601, is recommended for all temperature conditions.

Grease all fittings every four to eight hours of operation (see maintenance schedule). Grease until extrusion is visible.

After greasing the rotation bearing, rotate the attachment through two full rotations. The cylinder and pivot should be greased at four hours and eight hours of operation, while the attachment is warm. The bracket and rotation should be greased at the end of an eight-hour shift.

### Grease locations:

1. Bracket cylinder
2. Bracket pivot
3. Attachment cylinder rod
4. Attachment cylinder butt
5. Main shaft/pivot (both sides)
6. Rotation bearing (four locations)
7. Rotation bearing gear teeth

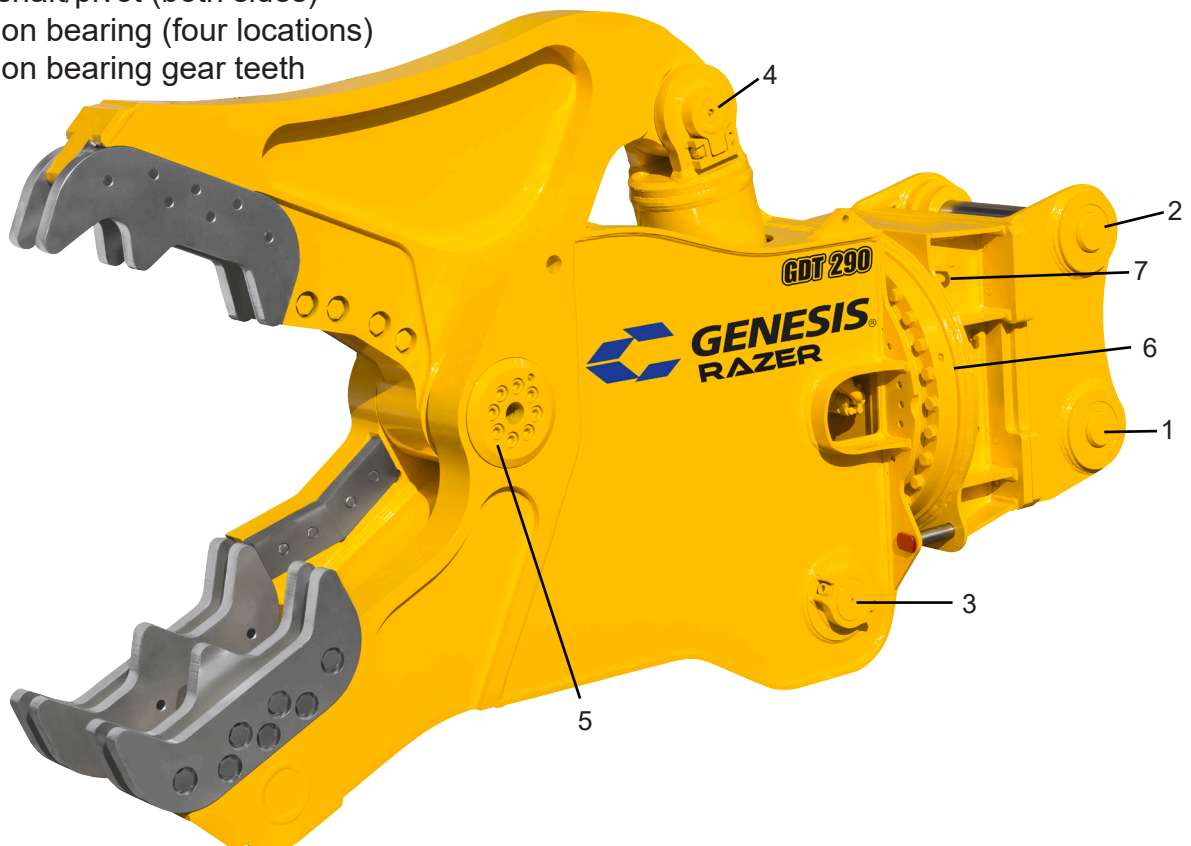

## **BOLT TORQUE SPECS**

**Bolt torque specs and thread treatment procedures can be found in the  
Genesis Fastener Manual.**

**[genesisattachments.com/manuals](https://genesisattachments.com/manuals)**

## TOOTH AND BLADE MAINTENANCE

Blade, tooth, pocket and blade seat maintenance greatly affects performance. To maximize performance and optimize the life of replaceable parts, follow all instructions for checks, adjustments and maintenance described in this section, at the intervals listed in the maintenance schedule in this manual.

Before performing maintenance, read, fully understand and follow these safety rules.

Wear personal safety equipment including gloves, safety glasses, safety boots and proper clothing.

Safe blade maintenance requires two people - one to steady the blade while the other loosens the bolts.

Blades are heavy and may fall out of the blade seat if not adequately supported. Bystanders must stand clear.

Never strike a blade with a hardened steel tool. The blade may fragment, creating sharp flying debris.

### Pulverizing Teeth

As teeth become worn, they need to be rotated, built-up or replaced.

To help customers determine and monitor how far processor teeth have worn from their original shape, Genesis has created tooth build-up templates.

Each template is sized and formed to that tooth's original shape and features three lines that indicate wear level. Simply place the template over the tooth to determine the amount of wear and build-up required or if replacement is needed.



<b>Line 1</b>	½" wear - schedule maintenance to flip or rotate in jaw
<b>Line 2</b>	1" wear - flip, rotate in jaw or build up
<b>Line 3</b>	1½" wear - replace, if all points are worn on flippable teeth

See the following page for part numbers and contact your local Genesis dealer or the Genesis Parts Department to order.

At the end of each shift, check the condition of pulverizing teeth. Replace any broken bolts, and retorque loose bolts when cool.

Replace teeth when tip becomes severely rounded or flat. A more pointed tooth will process concrete more efficiently.

Pulverizing teeth may be welded to tooth holder if desired.

# TOOTH AND BLADE MAINTENANCE

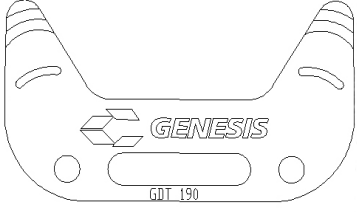
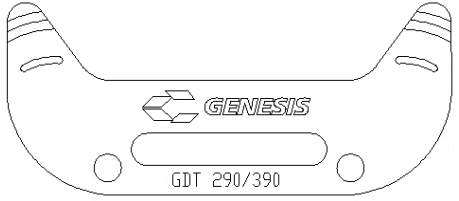
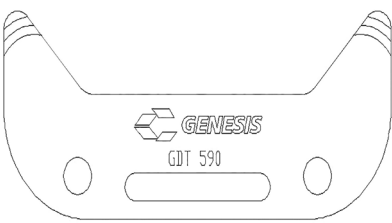
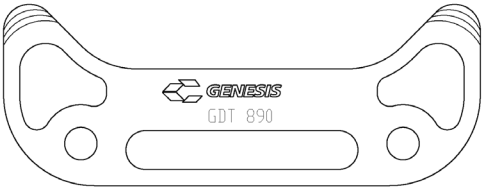
Model	Part Number	Template
190	9102985	
290 & 390	9102930	
590	9103745	
890	9104041	

## Hard-Surfacing Teeth

When building-up and/or hard-surfacing concrete crushing teeth, Genesis recommends keeping hard-surfacing a minimum of 1.00 inch away from the tooth profile root.

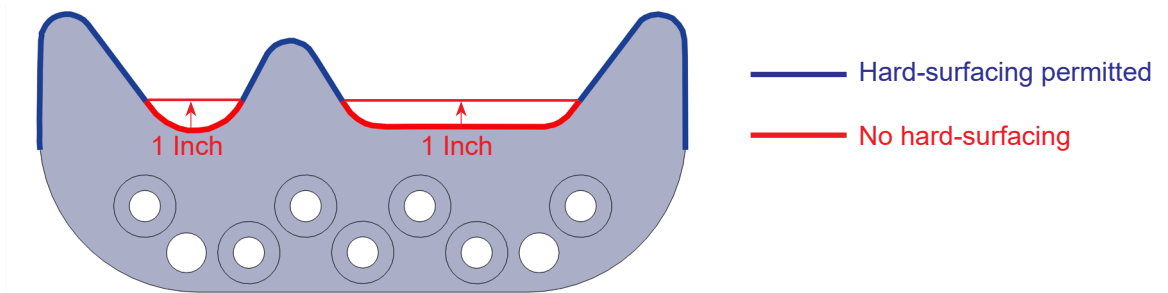

Hard-surfacing in the red areas can lead to premature tooth failure.

Always build-up/hard-surface with the grain of the tooth. Do not weld across the tooth.

Hard-surface material should have less than 10% chrome content and be applied on top of a 7018 root pass.

# TOOTH AND BLADE MAINTENANCE

## **Cutting Blades**

Proper maintenance of the cutting blades is required for optimal performance. Blade rotation extends blade life and improves cutting performance. Shimming to maintain blade tolerances helps prevent jamming.

Inspect blades every eight hours of operation. Replace any broken bolts, and retorque loose bolts when cool. Grind away dents or mushrooming of blade edges at the end of each day to prevent upper jaw deflection, excessive blade wear and undue stress to jaws.

Rotate blades to use all four cutting edges. Always use Genesis-approved blades. Blades that do not meet Genesis specifications can cause major problems, and using them may void the warranty.

## **Blade Removal**

Loosen the bolts on one blade at a time, enough to loosen the blades. Carefully remove bolts and blades.

## **Blade Rotation**

Rotate blades when the cutting edges are worn to a 1/8" (3mm) radius.

Recommended rotation intervals are approximately 40-80 hours, depending on the material being processed. Thin materials may require shorter rotation intervals. Blades must be replaced when all four edges are worn to 1/8" (3mm) radius.

The following chart may be copied and used to track blade rotation.

<b>40 - 80 Hours</b>	<b>Date</b>	<b>Hour Meter</b>	<b>Performed By</b>
<b>Installed</b>			
<b>Rotation 1</b>			
<b>Rotation 2</b>			
<b>Rotation 3</b>			

# TOOTH AND BLADE MAINTENANCE

## **Blade Gap**

After each blade rotation, shim lower blades to keep the gap within a range of 0.010" to 0.020". Do not shim the upper blades. Use only Genesis shim kits.

## **Blade Gap Measuring Procedure**

Slowly close jaws until blades begin to bypass. Stop the jaw and check the gap with a feeler gauge.

Cycle the jaws slowly and continue checking the gap at several points along the entire length of the blades.

Note: The gap will be consistent along the entire length of the blades if they have been rotated and shimmed correctly.

If blade gap exceeds the 0.020", shim lower blades. Blades must be replaced when shims exceed 0.060".

## **Shimming Procedure**

Loosen blade bolts.

Install shims between blade and blade seat as needed to bring into tolerance.

Torque bolts to spec and recheck tolerances.

Do not use more than 0.060" of shims.

## GENERAL WELDING GUIDELINES

Build-up and hard-surfacing are welding procedures that protect the parent material of the jaws and keep the tool in good condition. Build-up is the welding procedure that restores the jaws to their original shape. Building up the jaws helps protect the blades and increases the life of the attachment. Hard-surfacing is the welding material added over the parent material (or build-up material) to create a wear-resistant surface.

Welding should not be performed until the jaws are work-hardened. Work-hardening can take up to 80 hours.

### **Welding Ground Clamp**

**Disconnect all battery ground cables or shut off master battery switch, if equipped.**

**Failure to do so may cause excavator electrical problems, including permanent damage to onboard computer systems.**

**Connect ground clamp as close as possible to the area being welded without allowing current to pass through the pivot group, cylinder pin, cylinder, swivel, motor, gearbox or slewing ring.**

**If you are welding on the lower jaw, connect weld clamp to the lower. If you are welding on the upper jaw, connect to the upper but not to the cylinder clevis. If needed, weld a piece of steel to the area for the grounding clamp and cut the piece off when welding is completed.**

### **Welding Rules**

Before you begin:

- Remove adjacent blades, as preheating and welding may cause damage.
- Do not remove teeth, as weld spatter on tooth holder would cause fitment problems.
- Wearing an approved respirator, grind the area to clean it and remove all existing hard-surfacing.
- Preheat area to 350° F (177° C). Maintain this temperature throughout the procedure. Do not exceed 450° F interpass temperature.

During welding:

- Always grind and weld with the grain of the material.
- Peen each weld pass to relieve stress and harden the welds.
- Do not undercut the ends of the welds.

After welding maintenance is complete:

- Cover the area with a heat blanket and allow it to cool slowly, approximately eight hours.
- Do not put the attachment into operation until the welds have been allowed to cool.

# BUILD-UP AND HARD-SURFACING

Procedure:

Follow the General Welding Guidelines and Rules.

Determine the area to build up, using a straight-edge or square. Do not allow jaws to wear to more than a 3/4" radius on edges of tool.

Build up the jaw to slightly higher than the original parent material profile with E7018. Apply single passes in each line with the grain of the steel, peening after each pass.

See drawings for grain, as indicated by arrows. (Red lines indicate hard-surfacing pattern.)

After build-up is complete, grind material to be flush with the flat surfaces of the tool or, if building up a blade seat, grind material to be flush with a new blade.

## Hard-Surfacing Patterns

Where parallel lines are shown, apply single passes approximately 1" apart. Cover exposed faces with a crosshatch pattern with stringer beads at 45° angles to form 1" squares.

Hard-surfacing patterns are indicated by red lines in the drawings. Crosshatch may be used in place of straight stringers on any flat areas of the jaws and on the outside of the upper jaw.

**Do not crosshatch the curved areas of the jaws near the pivot.** Use only straight stringers on these areas.

Follow hard-surfacing instructions on the following page.

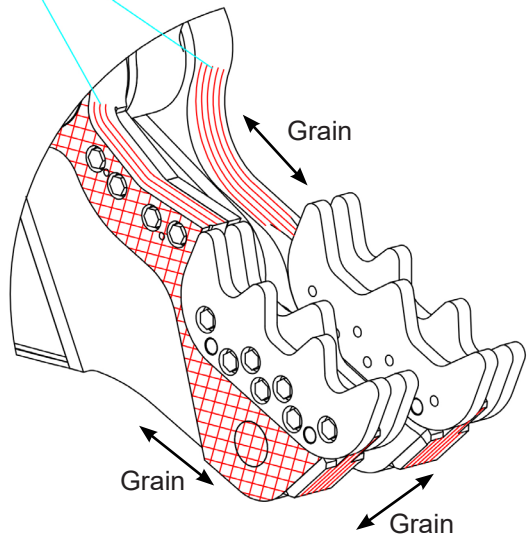
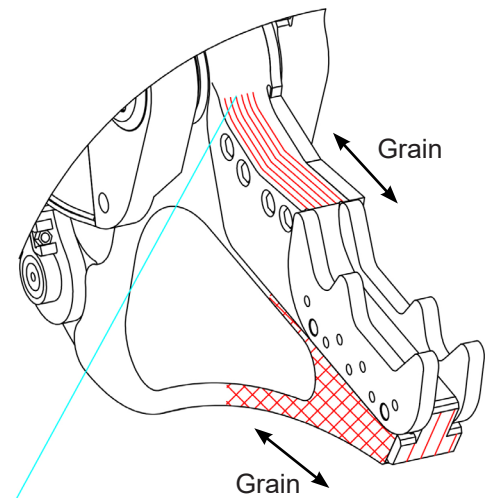

## HARD-SURFACING

Do not apply hard-surfacing directly to the parent material as this could cause toe cracking, and the hard-surfacing will break away.

Procedure:

Follow the General Welding Guidelines and Rules.

Apply a single pass stringer bead pattern, with the grain, using E7018 electrode. Peen each pass.

Do not apply a stringer directly on the edge. Start the first pass 1/4" from the edge.

Stagger the ends of the stringer welds so they do not end in a straight line.

Cap each stringer bead with one pass of GenWire or GenRod to hard-surface. Do not apply more than two layers of hard-surfacing. Peen each pass.

Grind the ends of all stringer welds, with the grain to taper 1" to 1-1/2" (25 - 38 mm) to the parent material.

See the previous page for hard-surfacing illustrations and instructions specific to each area of the jaws.

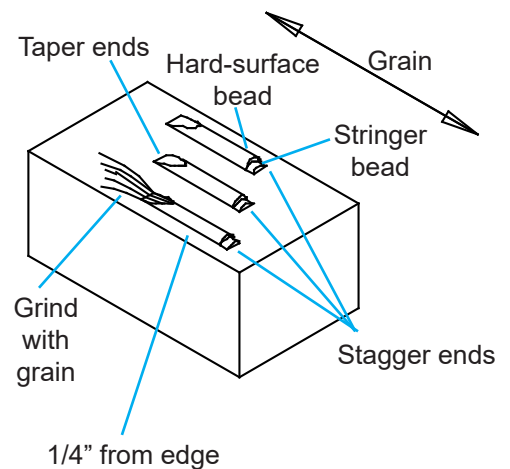

# HYDRAULIC/ROTATION MAINTENANCE

## Hydraulic Requirements

Operating the attachment below the recommended flow and/or pressure range will adversely affect performance and may damage the rotate motor.

**Operating the attachment above the recommended flow and/or pressure range may damage the attachment and its hydraulic components.**

Model	Flow	Pressure
190	40 - 60 GPM 151 - 227 LPM	4,500 - 5,500 PSI 310 - 380 Bar
290	60 - 100 GPM 227 - 379 LPM	
390	80 - 100 GPM 303 - 379 LPM	
590	80 - 200 GPM 303 - 757 LPM	
890	130 - 200 GPM 492 - 757 LPM	

## Rotation Valve Input

For cooler and more efficient hydraulic system operation, set the input pressure and flow as indicated in the chart. The attachment rotation speed should be 3 - 4 RPM. Exceeding 4 RPM will result in rotation component damage.

Model	Flow	Supply Pressure	Crossover Relief
190 & 290	3 - 5 GPM 11 - 19 LPM	1,800 - 2,000 PSI 124 - 138 Bar	2,200 PSI 152 Bar
390 - 890	7 - 11 GPM 26 - 42 LPM		

The maximum case drain pressure measured at the shear while rotating and cycling the jaws must never exceed 40 PSI. Pressure increases during cold-weather operation.

## HYDRAULIC/ROTATION MAINTENANCE

### GenFlow Regeneration Valve

A regeneration valve features a GenFlow adjustment cartridge to control the timing of the shift between speed and power modes. When the cartridge is properly set, the processor closes rapidly until it begins to cut. The valve shifts, slowing jaw close and increasing power. You may hear a squeal or hiss as this happens. The valve shifts back into speed mode after the cut is complete.

The cartridge is factory-set, turned out approximately five turns. This setting is appropriate for most applications. However, the cartridge may be custom-set if necessary.

### Regeneration Valve Adjustment

Regeneration valve adjustment is a two-person job. The ground crew must be in full view of the operator at all times and must stand clear of the processor jaws when cycling.

Check the cycle time when the hydraulic fluid is warmed up, timing from full open to full closed and back to full open.

To shift into power mode sooner, turn adjustment cartridge out (counter-clockwise). To shift into power mode later, turn in (clockwise).

Loosen the lock nut with a 9/16" socket.

Turn cartridge 180° (half-turn, 145 PSI) with a 5/16" allen-head socket.

Tighten lock nut.

Check the cycle time.

Repeat until the preferred balance of speed and power is met. Final adjustment may require less than a half-turn.

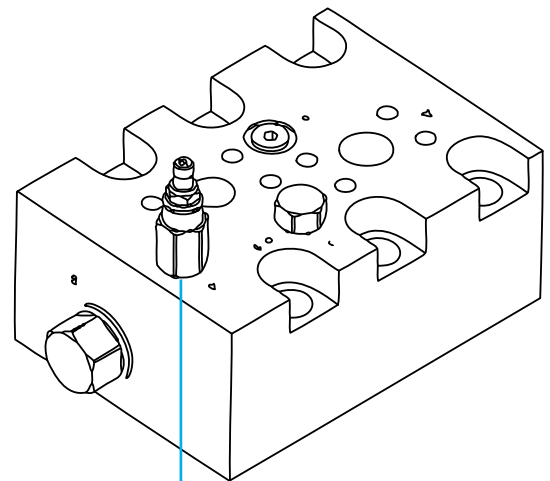

Adjustment Cartridge



Shut off the excavator and disable the hydraulics per OEM instructions before adjusting the cartridge.

## GENFLOW REGENERATION VALVE - HOW IT WORKS

**Jaw Close in Regeneration:** Oil that would normally leave the rod end of the cylinder and return to the tank is diverted to the bore end of the cylinder, increasing flow by approximately 50 percent and speeding up jaw close. In this mode, oil pressure on both rod and bore sides of the cylinder piston are basically equal and, although this speeds up the cylinder extend speed, it results in pressurized fluid on the rod side. If left in this mode, cylinder power is greatly reduced.

**Jaw Close in Power Mode:** To provide full power, when the upper jaw hits the material, the pressure rises. Once pressure exceeds the adjustment cartridge settings, it then shifts the rod oil back to the excavator hydraulic tank instead of the bore end of the cylinder. Pressure in the rod also drops, allowing full force from the bore pressure to be applied to the upper jaw for full cutting.

**Jaw Open:** Oil goes to the rod end of the cylinder, and bore oil goes back to the tank.

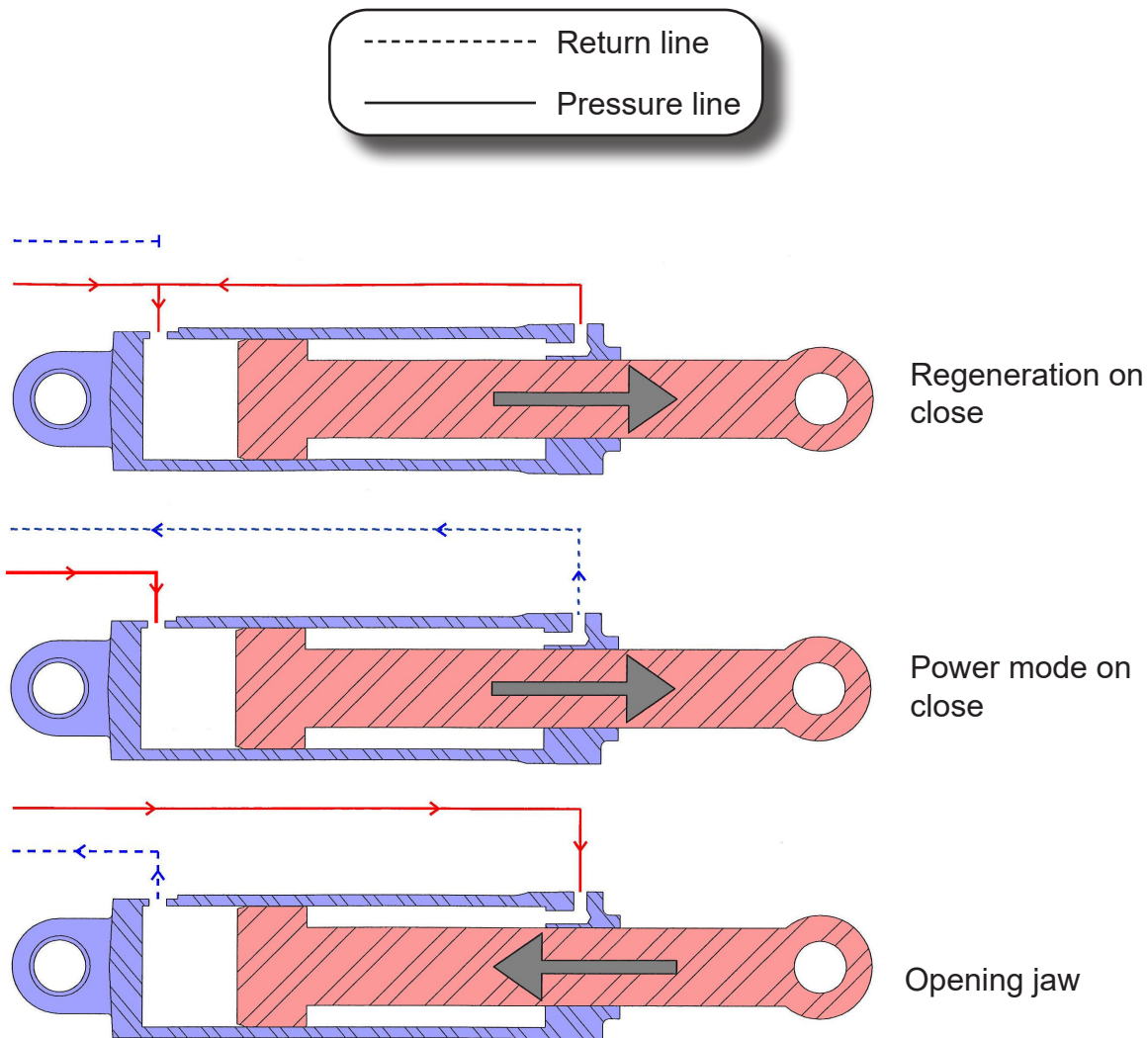

# GENFLOW REGENERATION VALVE

## GDT 190 & 290

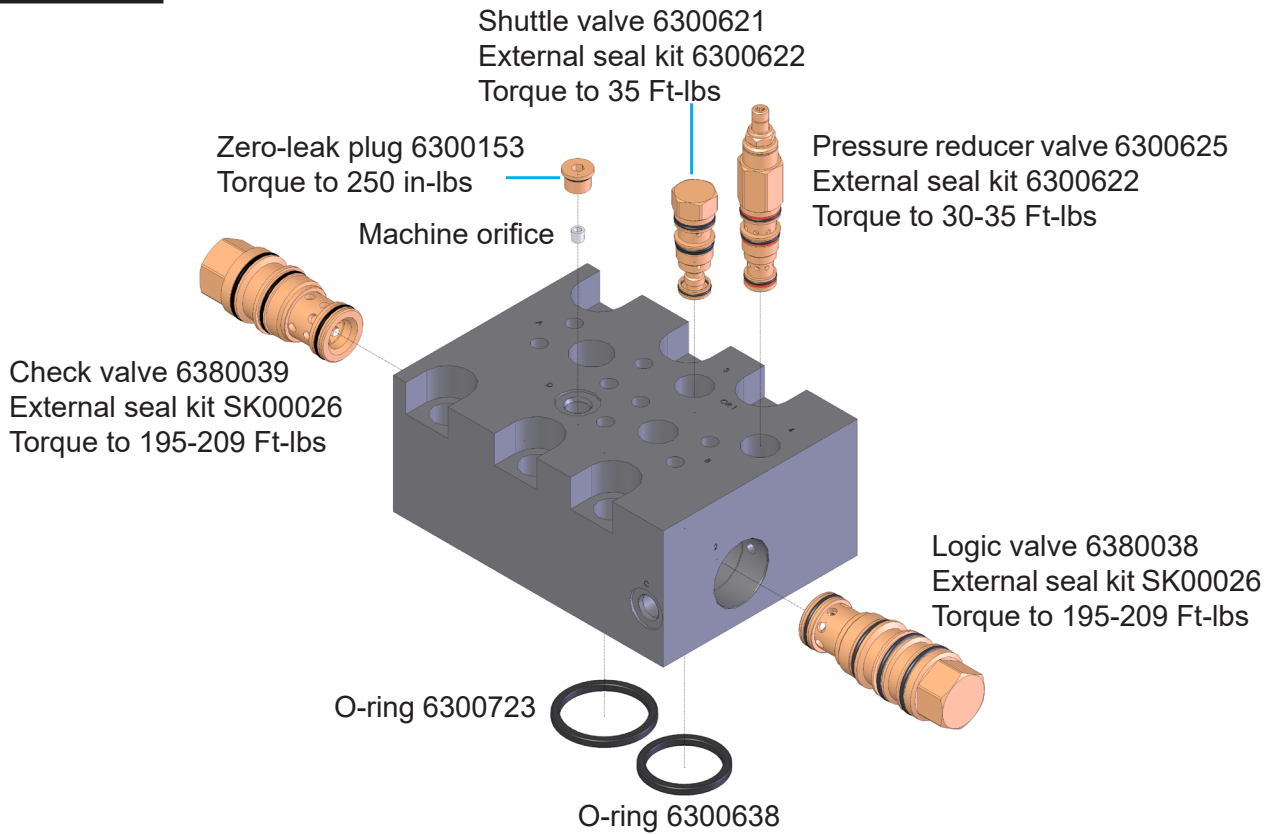

## GDT 390

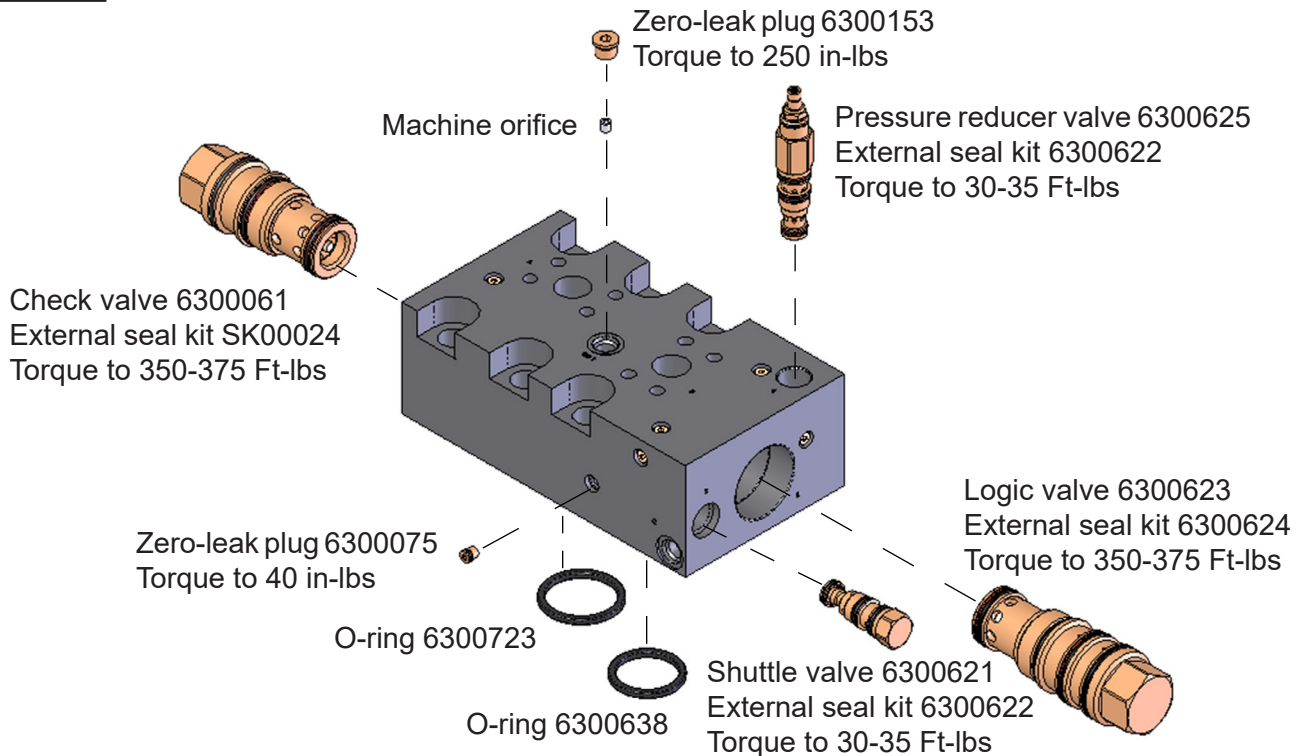

# GENFLOW REGENERATION VALVE

## GDT 590 & 890

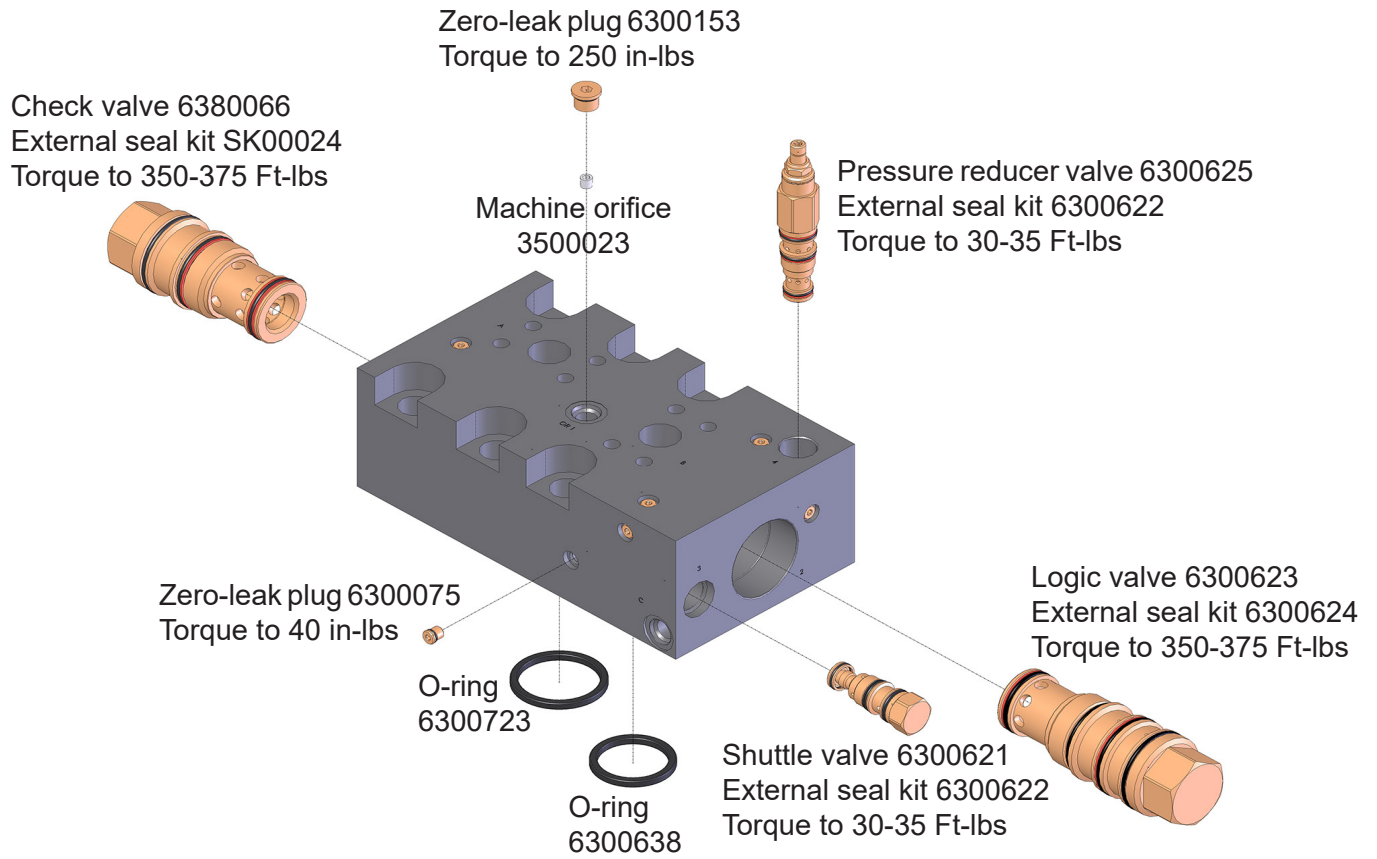

## SLEWING RING MAINTENANCE

Visually check slewing ring (rotation bearing) bolts every eight hours of operation. Do not reuse or re-torque these bolts. Loose or broken bolts, along with the bolts on either side, must be immediately replaced.

The bolts that secure the slewing ring are critical for safe attachment operation. Improper torque may cause the bolts to fail and the attachment to break free, which may result in serious personal injury and equipment damage. Improper torque will also cause uneven slewing ring wear.

Rotating components must be greased daily. Grease fittings are located on the outside of the slewing ring and on the inside of the rotating head assembly. Grease locations are marked with decals.

Grease each fitting and then rotate the attachment two full rotations.

For normal conditions above 32°F (0°C), use a lithium-based, premium grade 2 extreme-pressure grease. For temperatures below 32°F, use a grade 0 grease. **Do not use grease containing Molybdenum (Moly).**

Genesis GLG-2® anti-wear, extreme-pressure lithium grease, PN 6302601, is recommended for all temperature conditions.



Stand clear when the attachment is being rotated. Always stay in clear view of the operator.

# ROTATION CIRCUIT

Valves are factory-set and should not need adjustment. If you believe adjustment is necessary, contact the Genesis Service Department.

Note: Genesis does not recommend using the excavator bucket circuit for rotation circuit directional control as it will lead to motor failures.

All rotation circuits use the same procedure for setting flow:

- Rotate attachment, timing one complete revolution.
- Adjust corresponding flow control until revolution time is 14-16 seconds.
- Repeat in opposite direction.

## Rotation with Motion Control Valve

Setting the crossover reliefs:

1. Increase supply pressure to the rotation valve to 2500 PSI.
2. Install pressure gauges in feed lines.
3. Secure the attachment from rotating.
4. Pressurize the valve to rotate.
5. Adjust the corresponding relief valve to the pressure specified in the rotation valve settings table.
6. Repeat for the other direction.
7. Reduce supply pressure to the pressure-reducer valve setting specified in the rotation valve settings table.

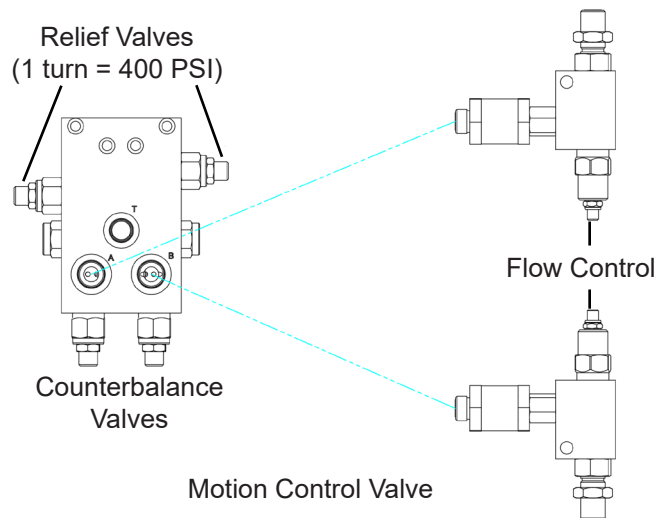

If you cannot reach the pressure specified in the rotation valve settings table, adjust the counterbalance valves using the following procedure:

- Turn the crossover relief valve adjustment screws clockwise to their maximum setting, recording the number of turns so they can later be returned to their original setting.
- Adjust the counterbalance valves by turning the adjustment screws counter-clockwise until the correct setting of 2500 PSI is reached.
- Repeat steps 6 and 7 for setting the crossover reliefs.

If you have questions regarding setting your rotation circuit, please contact the Genesis Service Department.

# TROUBLE-SHOOTING GUIDE

Symptom	Possible Causes/Solutions
Low power	Check pressures and back pressure at port blocks on attachment
	Isolate attachment from excavator and check excavator pressures at boom tip or arm
	Attachment may be partially stuck in regen mode; follow adjustment procedure
	If speed is good with low power, internal seals on logix cartridge may need to be replaced
	Possible cylinder, swivel or regen bypass (contact Genesis Service Department for procedures)
Slow jaw open with low power	Pilot check valves in regen valve may have worn or damaged seals
Slow jaw close	Check flows from excavator
	Check regen relief valve adjustment if attachment is new
	Adjustment cartridge may have damaged seals or may be stuck open
	Regen check valve or logix valve may have damaged seals or may be stuck open
Good speed but attachment stalls before cutting	Regen adjustment cartridge is turned in too far
Jaw drifts closed or can be pushed closed	Bleed down orifice may be plugged
	Pilot check valves may be leaking
	Directional valve on excavator may be leaking
Jaw closes suddenly and will not open	Ball valve may be partially closed on excavator
	Pilot check valves may be contaminated
	Excavator spool may be stuck
	If attachment has quick-coupled hydraulics, they may be partially disconnected or damaged
Hydraulics chatter while cutting	Tighten regen adjustment cartridge in 1/4 turns and recheck speed
	Chattering may indicate a material jam
Jaw bounces back after hitting excavator relief on jaw open	Bleed down orifice plugged
	Logix cartridge needs to be replaced
Loud bang when shifting to speed mode	Broken spring or poppet in logix cartridge
Hydraulic system overheating	Check hydraulic system oil level for low or overfull condition
	Ensure clear path for hydraulic cooler-radiator and A/C condenser; clean coolers and radiator with compressed air and pressure wash
	Check with excavator dealer on whether a hot weather package needs to be installed on the excavator. Note, oil temperatures coming out of the attachment can run as high as 230 to 240 degrees Fahrenheit.

## TROUBLE-SHOOTING GUIDE

Symptom	Possible Causes/Solutions
Poor Cutting	Material is beyond attachment appetite range
	Material is harder than mild steel
	Blades are worn beyond 1/8" radius - rotate or replace
	Blade gaps are too wide for thin material
	Blade protection strips are too high, causing jaw deflection and excessive blade gaps
	Teeth and blades are worn and need to be replaced
	Too much end play in pivot group - shim to 0.002" to 0.005"
	Wear in main bearings causing jaw deflection and inconsistent blade gaps
	Pressures from excavator too low - check at attachment port blocks
	Attachment not kicking out of regeneration or kicking out at too high a pressure range - see Regeneration Valve section of manual
	Attachment swivel or cylinder is bypassing - contact Genesis Service Department for procedures to check for bypass
Material Jamming	Excessive blade gaps - shim to specs given in Cutting Blade section of manual
	Worn blades - rotate or replace
	Thin material may be wrapping around blades - fold material or draw a larger amount of material into jaws

## TROUBLE-SHOOTING GUIDE

Symptom	Possible Causes/Solutions
Does not rotate	Blown fuse
	Test for 24V at plugs on directional valve while depressing foot switch
	Incorrect pressure settings; reset
	Crossover Relief Valve damaged, stuck open or out of adjustment
Does not rotate in one direction	No electrical power to one side; test for 24V at plugs on directional valve while depressing foot switch
	Check if directional control valve shifts both ways while actuating foot switch in both directions
	Crossover Relief Valve damaged, stuck open or out of adjustment
Rotator chatters	Electrical short; back out flow controls
	Pressure settings too high; reset
	Power to both rotation solenoids at the same time; test for 24V at plugs on directional valve while depressing foot switch
Rotates faster in one direction	One flow control cartridge set higher than the other; reset
Rotates too fast or too slow	Flow control out of adjustment; reset
Rotation speed changed from original setting	Jam nut loosened on rotation valve
	Faulty cartridge (contamination)
	Faulty directional control valve
	Pressure set too low; reset

# WARRANTY

## **Claim Procedure**

Notify the Genesis Service Department of the potential warranty claim prior to making the repair. Digital pictures are very helpful for diagnosing problems and recommending repairs.

Contact the Genesis Service Department before making alterations, changes or repairs to any component that is going to be considered for warranty. Not doing so will void all Genesis warranty consideration.

The Genesis Service Department will issue an authorization number to track the repair costs, outgoing parts, and/or defective parts returning to the factory.

Replacement parts must be ordered using a purchase order number. Shipping is standard ground. Overnight shipping is available by request, and Genesis will not cover the shipping charge.

When the repair is complete, submit an invoice to the Genesis Service Department within 30 days. Include itemized internal labor reporting, parts lists and invoices for outside contractors. Reference the authorization number on all invoices.

When returning parts for warranty consideration, include a copy of any related Genesis paperwork along with any other necessary documentation to ensure proper processing and credit. The Genesis Service Department will provide the necessary forms.

Your account will be credited when the warranty claim is accepted.

## **Blade Warranty**

Standard warranty on blades will only be considered on the first edge, and wear on the edge must be 1/8" radius or less. Genesis does not warranty cutting blades that are cracked or broken from top to bottom (perpendicular to the long edge of the blade). Genesis also does not cover fasteners, the labor to replace wear components or collateral damage, such as blade seats, from broken blades, the piercing blade tang or adjustment plates.

**Please direct any questions to the Genesis Service Department: 715-395-5252**

# PARTS ORDER POLICY AND PROCEDURE

## **Parts Orders Should Include**

- Purchase order number
- Model and serial number of attachment
- Part number and quantity needed
- Shipping and billing address
- Method of shipment or required delivery date

## **Placing Orders**

Orders may be placed by phone or e-mail. To e-mail an order, use the form on the following page or your purchase order form. Contact information is located at the front of this manual.

## **Part Numbers**

Part numbers are listed in a separate Parts Manual or, if included, the Parts section of this manual. Contact the Genesis Parts Department with questions regarding part numbers, availability and pricing.

## **Shipping**

All orders will be shipped best way surface unless an alternate shipping method is requested. Shipping charges are not included in the purchase price of parts.

## **Invoices**

All invoices are due upon receipt. Any accounts with invoices open beyond 60 days are subject to review and may be placed on C.O.D. status without further notice.

## **Returns**

Many unused Genesis parts may be returned with proper documentation. Return shipping is the responsibility of the purchaser. Credit will be issued upon return, less a 25% restocking fee. Documentation is required for credit of returned parts. Contact the Genesis Service Department at 715-395-5252 for an RGA (Return Goods Authorization) number and form. An RGA must accompany every return. Items shipped without an RGA may be returned to sender.

## **Warranty Returns**

All parts returned to Genesis for warranty consideration must be returned with a completed RGA (Return Goods Authorization) provided by the Genesis Service Department. The form needs to be completed in its entirety, including any additional information requested by the Service Department. Return shipping is the responsibility of the sender and will be credited upon claim approval. A determination to accept or deny the claim will be made based upon the information available to Genesis. Warranty on purchased parts other than wear components is 6 months. There is no warranty period on wear parts or components.





**GENESIS®**

The Promise of Performance.

## CONTACT INFORMATION

### Genesis Attachments

1000 Genesis Drive  
Superior, WI 54880 USA

Toll Free: 888-SHEAR-IT  
(888-743-2748)

Phone: 715.395.5252

E-mail:  
info@genesisattachments.com

### Europe/Africa/Middle East Genesis GmbH

Teramostrasse 23  
87700 Memmingen, Germany

Phone: +49 83 31 9 25 98 0

Fax: +49 83 31 9 25 98 80

genesis-europe.com

E-mail:  
info@genesis-europe.com

### Asia Pacific Representative Office

24 Upper Serangoon View #12-28  
Singapore 534205

Phone: +65 9673 9730

E-mail:  
tchoo@genesisattachments.com

### Central America & Colombia

Cra 13A #89-38 / Ofi 613  
Bogota, Colombia

Phone: +57 1 610 8160 / 795 8747

E-mail:  
contact@themsagroup.com

View and download all manuals: [genesisattachments.com/manuals](http://genesisattachments.com/manuals)  
Patents: [genesisattachments.com/products/patents](http://genesisattachments.com/products/patents)

Rev. 6-10-26