

# GDT Hydraulic/Rotation Maintenance

## HYDRAULIC REQUIREMENTS

Operating the attachment below the recommended flow and/or pressure range will adversely affect performance and may damage the rotate motor.

**Operating the attachment above the recommended flow and/or pressure range may damage the attachment and its hydraulic components.**

| Model | Flow                        | Pressure                       |
|-------|-----------------------------|--------------------------------|
| 190   | 40-60 GPM<br>(151-227 LPM)  | 4500-5500 PSI<br>(310-380 Bar) |
| 290   | 60-100 GPM<br>(227-379 LPM) |                                |
| 390   | 80-100 GPM<br>(303-379 LPM) |                                |

## ROTATION VALVE SETTINGS

When checking the crossover relief valve settings, put pressure gauges on both diagnostic ports. Stall attachment rotation in clockwise direction. Increase supply pressure until pressure at gauge on crossover stops rising. This is the crossover relief setting. Increase supply pressure to achieve approved crossover relief value. Repeat procedure in counter-clockwise direction. Then lower supply pressure back to approved value.

| Model | Flow                    | Supply Pressure                | Crossover Relief      |
|-------|-------------------------|--------------------------------|-----------------------|
| 190   | 3-5 GPM<br>(11-19 LPM)  | 1500-1900 PSI<br>(103-131 Bar) | 2200 PSI<br>(152 Bar) |
| 290   |                         |                                |                       |
| 390   | 7-11 GPM<br>(26-42 LPM) | 1900-2100 PSI<br>(131-145 Bar) |                       |

## GENFLOW REGENERATION VALVE

A regeneration valve features a GenFlow adjustment cartridge to control the timing of the shift between speed and power modes. When the cartridge is properly set, the processor closes rapidly until it begins to cut. The valve shifts, slowing jaw close and increasing power. You may hear a squeal or hiss as this happens. The valve shifts back into speed mode after the cut is complete.

The cartridge is factory-set, turned out approximately five turns. This setting is appropriate for most applications. However, the cartridge may be custom-set if necessary.

## REGENERATION VALVE ADJUSTMENT

Regeneration valve adjustment is a two-person job. The ground crew must be in full view of the operator at all times and must stand clear of the processor jaws when cycling.

Check the cycle time when the hydraulic fluid is warmed up, timing from full open to full closed and back to full open.

To shift into power mode sooner, turn adjustment cartridge out (counter-clockwise). To shift into power mode later, turn in (clockwise).

Loosen the lock nut with a 9/16" socket.

Turn cartridge 180° (half-turn, 145 PSI) with a 5/16" allenhead socket.

Tighten lock nut. Check the cycle time.

Repeat until the preferred balance of speed and power is met. Final adjustment may require less than a half-turn.

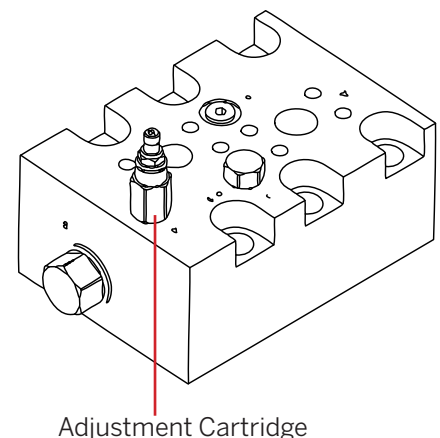

**⚠ DANGER** Shut off the excavator and disable the hydraulics per OEM instructions before adjusting the cartridge.

This document is a quick reference only. It does not replace the product safety and operator's manuals, which must be followed by all operators and maintenance personnel.