

**GENESIS**<sup>®</sup>

The Promise of Performance.

## Cyclone 30 (GCG 30)

### SAFETY & OPERATOR'S MANUAL



## CONTACT INFORMATION

### Genesis Attachments

1000 Genesis Drive  
Superior, WI 54880 USA

Toll Free: 888-SHEAR-IT  
(888-743-2748)

Phone: 715.395.5252

E-mail:  
info@genesisattachments.com

### Europe/Africa/Middle East Genesis GmbH

Teramostrasse 23  
87700 Memmingen, Germany

Phone: +49 83 31 9 25 98 0  
Fax: +49 83 31 9 25 98 80  
genesis-europe.com

E-mail:  
info@genesis-europe.com

### Asia Pacific Representative Office

24 Upper Serangoon View #12-28  
Singapore 534205

Phone: +65 9673 9730

E-mail:  
tchoo@genesisattachments.com

### Central America & Colombia

Cra 13A #89-38 / Ofi 613  
Bogota, Colombia

Phone: +57 1 610 8160 / 795 8747

E-mail:  
contact@themsagroup.com

View and download all manuals: [genesisattachments.com/manuals](http://genesisattachments.com/manuals)  
Patents: [genesisattachments.com/products/patents](http://genesisattachments.com/products/patents)

## PREFACE

To ensure years of safe, dependable service, only trained and authorized persons should operate and service your Genesis attachment. It is the responsibility of the product's owner to ensure the operator is trained in the safe operation of the product and has available this manual for review. It is the responsibility of the operator and maintenance personnel to read, fully understand and follow all operational and safety-related instructions in this manual. The attachment should not be operated until you have read and fully understand these instructions. Always use good safety practices to protect yourself and those around you.

### **Important**

This operator's manual must accompany the attachment at all times and be readily available to the operator.

### **Manual Replacement**

Should this manual become damaged or lost or if additional copies are required, immediately contact any authorized Genesis dealer or the Genesis Service Department at 888-743-2748 or 715-395-5252 for a replacement.

### **Registration Form**

The Warranty Registration Form must be filled out by the dealer or customer and returned to Genesis indicating the date the attachment went into service.

### **Possible Variations**

Genesis cannot anticipate every possible circumstance that might involve a potential hazard as the owner's requirements and equipment may vary. Therefore, the warnings in this publication and on the product may not be all-inclusive, and you must satisfy yourself that the procedure, application, work method or operating technique is safe for you and others before operating.

### **Public Notice**

Genesis reserves the right to make changes and improvements to its products and technical literature at any time without public notice or obligation. Genesis also reserves the right to discontinue manufacturing any product at its discretion at any time.

### **Warranty**

All work or repairs to be considered for warranty reimbursement must be pre-authorized by the Genesis Service Department. Any alterations, modifications or repairs performed before authorization by the Genesis Service Department will render all warranty reimbursement consideration null and void without exception. See page 36 for Warranty Claim Procedures.

Improper operation or improperly performed maintenance may render any warranty null and void.

# TABLE OF CONTENTS

<b>CONTACT INFORMATION</b>	<b>2</b>
<b>PREFACE</b>	<b>3</b>
Important	3
Manual Replacement	3
Registration Form	3
Possible Variations	3
Public Notice	3
Warranty	3
<b>SAFETY STATEMENTS</b>	<b>6</b>
<b>GENERAL SAFETY PRECAUTIONS</b>	<b>7</b>
Read Manual Prior to Operation	7
Read and Understand All Safety Statements	7
Know Your Equipment	7
Protect Against Flying Debris	7
Lower or Support Raised Equipment	7
Do Not Modify Excavator or Attachment	8
Safely Maintain and Repair Equipment	8
Safely Operate Equipment	8
<b>OPERATIONAL SAFETY</b>	<b>9</b>
Use Care with Hydraulic Fluid Pressure	9
Know Where Utilities Are	10
Remove Paint Before Welding or Heating	10
End of Life Disposal	10
Intended Use	10
Misuse	11
Personal Protective Equipment	12
Warning Decals	13
Operating the Attachment	14
<b>TRANSPORTING</b>	<b>15</b>
Transport Sling Point	15
Center of Gravity	15
Transport of Unpacked Machinery and System Parts	16
<b>ATTACHMENT MARKINGS</b>	<b>17</b>
<b>INSTALLATION</b>	<b>18</b>
Output Rating	18
Hydraulic Oil	18
Quick Coupler	19
Flow Limiting Device	19
Leak Oil Line Installation	19
Underwater Applications	19
Pressure and Oil Volume	20
Prior To Start-Up	21
With the Cyclone Running	21
<b>DISASSEMBLY &amp; STORAGE</b>	<b>22</b>
Disassembly	22
Storage	22

# TABLE OF CONTENTS

<b>OPERATING</b> .....	<b>23</b>
<b>APPLICATION EXAMPLES</b> .....	<b>24</b>
<b>DRUM TYPES</b> .....	<b>25</b>
Rock.....	25
Profiling.....	25
Demolition.....	25
<b>TECHNICAL DATA</b> .....	<b>26</b>
Cutting Drum Dimensions.....	26
<b>MAINTENANCE</b> .....	<b>27</b>
Cleaning.....	27
Maintenance Schedule.....	27
Pick Replacement.....	28
Disassembly of a Pick with Retaining Ring.....	28
Pick Installation.....	29
Assembly of a Pick with C-Retaining Ring.....	29
Checking the Slide Ring Packing.....	30
Cutting Drum Removal/Installation.....	31
Hydraulic Motor Flushing/Filling.....	32
Check Hydraulic Motor Condition.....	33
<b>TROUBLE-SHOOTING GUIDE</b> .....	<b>34</b>
Cutting Performance Declines.....	34
Cutting Drums Do Not Rotate.....	34
Oil Leakage at External Components.....	35
Oil Leakage.....	35
Only One Cutting Drum Rotates.....	35
<b>WARRANTY</b> .....	<b>36</b>
Claim Procedure.....	36
<b>PARTS ORDER POLICY AND PROCEDURE</b> .....	<b>37</b>
Parts Orders Should Include.....	37
Placing Orders.....	37
Part Numbers.....	37
Shipping.....	37
Invoices.....	37
Returns.....	37
Return Goods Authorization.....	37
<b>PARTS ORDER FORM</b> .....	<b>38</b>
<b>CONTACT INFORMATION</b> .....	<b>39</b>

## SAFETY STATEMENTS



This symbol by itself or used with a safety signal word throughout this manual is used to call attention to instructions involving your personal safety or the safety of others. Failure to follow these instructions can result in injury or death.



This statement is used where serious injury or death will result if the instructions are not followed properly.



This statement is used where serious injury or death could result if the instructions are not followed properly.



This statement is used where minor or moderate injury could result if the instructions are not followed properly.

**NOTICE**

This statement is used where property damage could result if the instructions are not followed properly.

## GENERAL SAFETY PRECAUTIONS

### **Read Manual Prior to Operation**

Improper installation, operation or maintenance of this equipment could result in serious injury or death. Operators and maintenance personnel should read this manual, as well as all manuals related to this equipment and the excavator thoroughly before beginning installation, operation or maintenance. **FOLLOW ALL SAFETY INSTRUCTIONS IN THIS MANUAL AND THE EXCAVATOR MANUAL(S).**

### **Read and Understand All Safety Statements**

Read all safety decals and safety statements in all manuals prior to operating or working on this equipment. Know and obey all OSHA regulations, local laws and other professional guidelines for your operation. Know and follow good work practices when assembling, maintaining, repairing, mounting, removing or operating this equipment.

### **Know Your Equipment**

Know your equipment's capabilities, dimensions and operations before operating. Visually inspect your equipment before you start, and never operate equipment that is not in proper working order with all safety devices intact. Check all hardware to ensure it is tight. Make certain all locking pins, latches and connection devices are properly installed and secured. Remove and replace any damaged, fatigued or excessively worn parts. Make certain all safety decals are in place and legible. Keep decals clean and replace if they become worn or hard to read.



## **WARNING**

Serious injury or death could result if warnings or instructions regarding safe operation are not followed.

### **Protect Against Flying Debris**

Always wear proper personal protective equipment when driving pins in or out, or when any operation causes dust, flying debris or any other hazardous material. The Cyclone may cause severe injuries. Never stand within operating range.

### **Lower or Support Raised Equipment**

Do not work under raised booms without supporting them. Do not use support material made of concrete blocks, logs, buckets, barrels or any other material that could suddenly collapse or shift positions. Make sure support material is solid and not decayed, warped, twisted or tapered. Lower booms and attachments to the ground before leaving the cab.

## GENERAL SAFETY PRECAUTIONS

### **Do Not Modify Excavator or Attachment**

Modifications may weaken the integrity and impair the function, safety, life and performance of the attachment. When making repairs, use only the manufacturer's genuine parts, following maintenance instructions. Other parts may be substandard in fit and quality. Never modify any ROPS (Roll Over Protective Structure) or FOPS (Falling Object Protective Structure) equipment or device. Any modifications must be authorized in writing by the manufacturer.

### **Safely Maintain and Repair Equipment**

- Do not wear loose clothing or any accessories that can catch in moving parts. If you have long hair, cover or secure it so it does not become entangled in the equipment.
- Work on a level surface in a well-lit area.
- Use properly grounded electrical outlets and tools.
- Use the correct tools for the job. Make sure they are in good condition for the task required.
- Wear proper protective equipment.

### **Safely Operate Equipment**

Do not operate equipment until you are completely trained by a qualified operator in how to use the controls and know its capabilities, dimensions and all safety requirements. See your excavator manual for these instructions.

- Keep all step plates, grab bars, pedals and controls free of dirt, grease, debris and oil.
- Never allow anyone to be around the equipment when it is operating.
- Do not allow riders on the attachment or excavator.
- Do not operate equipment from anywhere other than the correct operator's position.
- Never leave equipment unattended with the engine running or the attachment in a raised position.
- Do not alter or remove any safety feature from the excavator or attachment.
- Know your work site safety rules as well as traffic rules and flow. When in doubt on any safety issue, contact your supervisor or safety coordinator for an explanation.



## OPERATIONAL SAFETY



### WARNING

Serious injury or death could result if warnings or instructions regarding hydraulic fluid pressure are not followed properly.

#### Use Care with Hydraulic Fluid Pressure

Hydraulic fluid under pressure can penetrate the skin and cause serious injury or death. Hydraulic leaks under pressure may not be visible.

- ✓ Keep unprotected body parts, such as face, eyes and arms as far away as possible from a suspected leak. Flesh injected with hydraulic fluid may develop gangrene or other permanent injuries.
- ✓ If injured by injected fluid see a doctor immediately.
- ✓ Wear safety glasses and protective clothing and use a piece of cardboard or wood when searching for hydraulic leaks.

**Do Not Use Your Hands!**  
**See illustration below.**

- ✓ Hydraulic oil becomes hot during operation. Do not let hydraulic oil or components contact skin, as it could cause severe burns. Allow hydraulic components to cool before working on them. Use appropriate protective clothing and safety equipment. If burned, seek immediate medical attention.

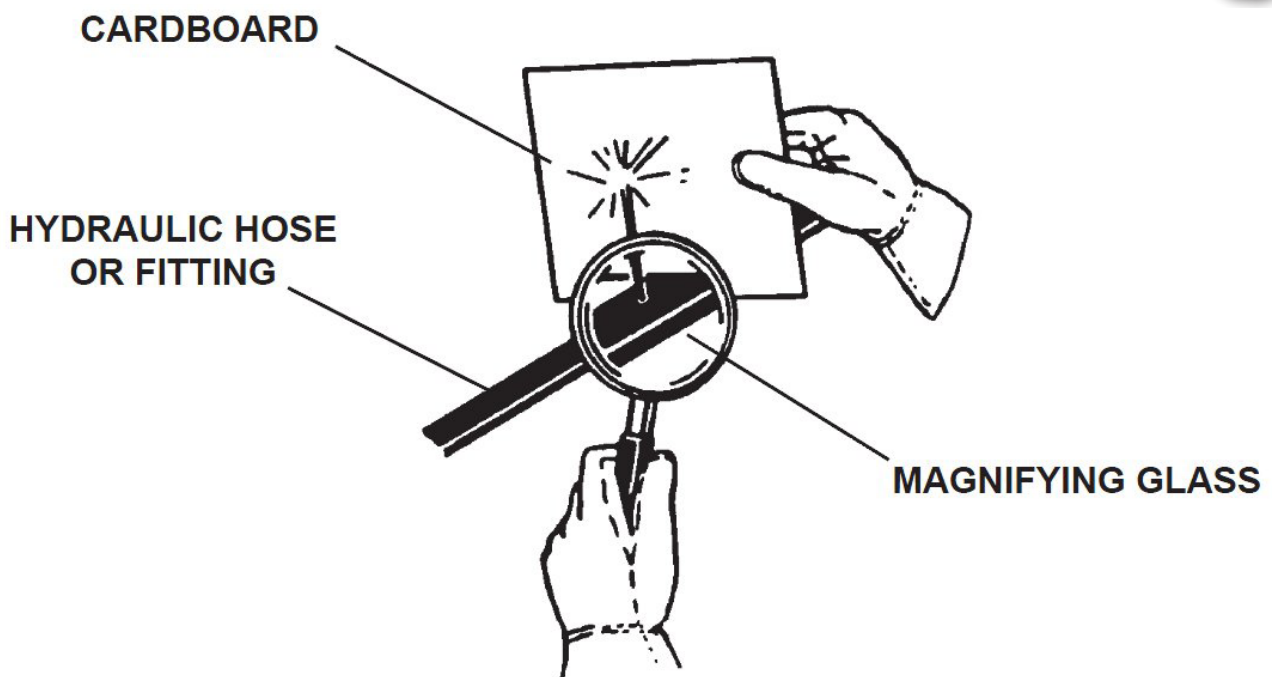

## OPERATIONAL SAFETY

### **Know Where Utilities Are**

Observe overhead electrical and other utility lines. Be sure equipment will clear them. When digging, call your local utilities for location of buried utility lines, gas, water and sewer, as well as any other hazard you may encounter.



**DANGER**

Exposure to respirable crystalline silica dust along with other hazardous dusts may cause serious or fatal respiratory disease.

The use of dust suppression, dust collection and personal protective equipment is recommended during the operation of any attachment that may cause high dust levels.

### **Remove Paint Before Welding or Heating**

Hazardous fumes/dust can be generated when paint is heated by welding, soldering or using a torch. Do all work outside or in a well ventilated area, and dispose of paint and solvent properly. Remove paint before welding or heating.

When sanding or grinding paint, avoid breathing the dust. Wear an approved respirator. If you use solvent or paint stripper, remove stripper with soap and water before welding. Remove solvent or paint stripper containers and other flammable material from area. Allow fumes to disperse at least 15 minutes before welding or heating.

### **End of Life Disposal**

At the completion of the useful life of the unit, drain all fluids and dismantle by separating the different materials (rubber, steel, plastic, etc.). Follow all federal, state and local regulations for recycling and disposal of the fluid and components.

### **Intended Use**

The Cyclone is referred to as exchangeable equipment for excavators that loosens and removes hard and solid materials such as rock, bitumen, timber, frozen soil and concrete. The Cyclone can be equipped with various drum types, and the picks used must be determined based upon the structure of the soil/rock being processed.

It is possible for the Cyclone to be operated in swampy areas or under water.

## OPERATIONAL SAFETY

The Cyclone may only be operated as intended. Intended use also includes compliance with the operating, maintenance and servicing conditions established by the manufacturer.

Any use other or beyond that specified is regarded as improper. The manufacturer shall not assume any liability for damage resulting from improper use. The risk for any such damage shall be borne by the user.

### **Misuse**

The following are regarded as improper use of the Cyclone.

- Operating the Cyclone with parameters (e.g. oil pressure) that are outside the specified limits.
- Operating the Cyclone with excavators for which it is not designed.
- Operating the Cyclone with damaged or missing picks.
- Operating the Cyclone in an incorrect rotation direction.
- Slamming the Cyclone onto the working surface while not rotating, which may damage the picks.
- Operating the Cyclone while people who have not received any safety instructions are in the hazardous area.
- Operating the Cyclone in potentially explosive atmospheres.

Any use other or beyond that stated above, such as with higher power values, at higher or lower speeds, in inappropriate operating conditions or following any structural modifications is regarded as improper.

## OPERATIONAL SAFETY

### Personal Protective Equipment

The following items of personal protective equipment must be worn during Cyclone operation.



Use eye protection



Use hearing protection



Wear protective gloves



Wear safety shoes



Wear protective clothing

# OPERATIONAL SAFETY

## Warning Decals

The following warning decals are attached to the Cyclone and should be replaced when worn.



Rotary Parts



Wear Goggles



Stand Clear



Projecting Parts



Release of Hydraulic Oil



Read Operating Manual



Return



Feed



## OPERATIONAL SAFETY

### Operating the Attachment

- Prior to beginning any cutting work, make sure no one will be in the proximity during operation. During operation, there is a risk of small fragments being ejected and causing injuries and property damage. In the event people enter or are present in the operating area unexpectedly, immediately stop the cutting process and shut down the motor.
- Due to the low cutting speed and depending on the type of layers, only slight dust formation occurs with the Cyclone. However, in rare cases with high degrees of dust generation, appropriate counter-measures must be taken (e.g. spray water systems, mobile/fixed anti-dust systems, wearing of personal protective equipment).
- Never allow anyone to touch or approach the Cyclone when in operation.
- Hazard points that occur between the Cyclone and excavator must be secured by the operator.
- The Cyclone generates heat, which increases the temperatures in the working environment. Consistent, appropriate ventilation must be available at all times.
- The Cyclone must be operated under appropriate lighting conditions.
- Do not operate the Cyclone on an excavator without the top and front guard shields or FOPS (Falling Object Protective Structure) installed.
- Do not exceed the excavator's rated operating capacity.
- Operate only from the operator's station.
- Never lift, move or swing an attachment over anyone.
- The attachment should not be used as a parking brake to immobilize the excavator or in any way to assist in moving the excavator. Follow the instructions in the excavator's operator's manual before leaving the operator's station.
- An operator must not use drugs or alcohol, which can change his or her alertness or coordination. An operator taking prescription or over-the-counter drugs should seek medical advice on whether or not he or she can safely operate equipment.
- Before exiting the excavator, lower the attachment to the ground, apply the brakes, turn off the excavator engine and remove the key.
- Before performing maintenance, service or inspection work, turn off the excavator engine and remove the key.
- Immediately replace cracked or damaged hoses and tubes.
- Only use original spare parts and immediately replace parts when damaged.
- The Cyclone must only be operated in safe and functional condition. Any necessary repairs should be made before continuing operation.
- Avoid any work and operating methods that limit or impair safety.
- The hazard areas of the Cyclone are specially marked. Observe the warning signs at the machine and keep them in legible condition.
- At a pressure greater than 725 psi, the pressure relief valve is triggered.
- Do not modify the Cyclone. This also applies for attachment and welding of load-bearing parts.
- During set-up, the Cyclone must only be operated by one person.



### **WARNING**

Using your Genesis attachment in unauthorized applications may create an unsafe situation and will void the warranty.



# TRANSPORTING

## Transport Sling Point



Minimum Load Rating  
(lbs)

Hooks	3307
Eyes	3307

## Center of Gravity

The center of gravity is where the eye bolt hole is. Redetermine the center of gravity after installation.



The center of gravity may shift due to attachment of other drums, adapter plates, quick couplers, rotators, etc. The Cyclone may topple over, injuring people or damaging property.

# TRANSPORTING

## Transport of Unpacked Machinery and System Parts

Unpacked machinery must only be transported by means of a transport frame.

### **Transport Using a Forklift**

- Make sure the forklift has sufficient load-bearing capacity. Load-bearing capacity per forklift equals total gross weight.
- Insert the fork underneath the transport unit.
- The center of gravity of the transport unit must be between the fork tines.
- There must be no parts between the fork tines and the transport unit.
- Pay special attention to the position of the fork, particularly while lifting the transport unit.
- If the transport unit becomes unstable during lifting, lower the transport unit, re-insert the forks and lift the unit again.
- The transport unit must always maintain a position parallel to the ground.
- Slowly and carefully move the transport unit to the installation site. Avoid any vibrations, impact and inclined positions.
- At the installation site, slowly and evenly lower the transport unit to the ground. Avoid jerky lowering or slamming.

### **Transport Using a Crane**

- Sling the hoisting gear at suitable points of the transport unit.
- Make sure the crane and hoisting gear have sufficient load-bearing capacity. Load-bearing capacity per rope/chain equals  $\frac{1}{2}$  gross weight.
- The angle of spread of the ropes/chains must not be larger than  $90^\circ$ .
- Carefully lift the transport unit and slowly and carefully move it to the installation site.
- At the installation site, slowly and evenly lower the transport unit to the ground. Avoid jerky lowering or slamming.
- Check for visible damage.



# ATTACHMENT MARKINGS



## INSTALLATION

Connect the Cyclone to the control circuit (hydraulics) of the excavator as described below.

- Connect the pressure line to the excavator and firmly tighten the screw fitting using an open-end wrench.
- Connect the return line to the excavator and firmly tighten the screw fitting using an open-end wrench.
- Enable the excavator hydraulic circuit.

### **Output Rating**

In order to correctly connect, the technical data of the Cyclone must be taken into account. See Technical Data, page 26.

<b>Connection of Pressure and Return Lines</b>	
Toward Cyclone	1" SAE 6000 PSI
Toward Excavator	4 SP 1" 60° SW41
Internal Hose Diameter	NW 25.4 SP



### **Hydraulic Oil**

- Oil type HLP 46 or 68
- HV mineral oil with improved viscosity/better temperature properties (DIN 50524, part 3)
- Category 46 viscosity at 40°C
- Category 68 viscosity at 40°C
- Biodegradable oil

A low degree of hydraulic oil contamination ensures longer service life of moving parts in the hydraulic motor (piston, manifold). The contamination degree must be below NAS 1638 Class 9. Insufficient filtration will limit the warranty.

## **NOTICE**

Contact Genesis prior to using any other hydraulic oil. The use of other hydraulic oil types must be approved in writing.

# INSTALLATION

## Quick Coupler

If several attachments are exchanged at the excavator, the use of a quick coupler is recommended. The following conditions must be met for quick couplers.

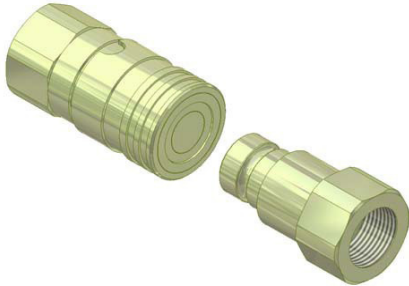

- Only use flat-type couplers
- Make sure the coupler is clean before it is (re-)connected
- Use at least one 1-inch coupler on both lines
- Use male and female connection fittings
- Make sure the counter pressure in the return line is not too high to prevent leakage

## Flow Limiting Device

The flow limiting device can be optionally ordered. It is auxiliary equipment that facilitates setting and adjusting the Cyclone.

## Leak Oil Line Installation

Installation should only be done by people who are experienced in working with hydraulic systems. The excavator must be equipped with a third line that is directly connected to the reservoir.

The leak oil line can be installed at any time but is only required when oil leaks from the overpressure line and it is not possible to appropriately adjust the excavator pressure to regulate the return line pressure.

1. Remove the Cyclone from the excavator
2. Remove the adapter plate
3. Remove the leak oil line from the leak oil accumulation at the return
4. Remove the sealing screw on the left or right side of the housing below the supply or return connection
5. Seal the connection of the leak oil accumulation at the return with the sealing screw
6. Connect the leak oil line to the port at the Cyclone housing
7. Connect the Cyclone to a leak oil line at the excavator. It must be taken into account that the leak oil line is designed for a pressure of at least 725 psi and has an internal diameter of ½ inch. **Using a leak oil line with a filter is recommended.**

## Underwater Applications

The Cyclone can be used in depths of up to 98 feet. However, in case of long-term applications at depths of more than 33 feet, please contact the Genesis Service Department. If the Cyclone is not connected via a leak oil line, connecting a line from the overpressure relief to the surface is recommended. Use a ½-inch hose and connect it to the ¼ BSP connection.

## INSTALLATION

### Pressure and Oil Volume

The initial Cyclone pressure and oil volume setting and adjustment should be performed by an authorized Genesis dealer or other qualified personnel.

The Cyclone is driven by the excavator's hydraulic system.

- Set the excavator hydraulic pressure to approximately 2973 psi
- Connect the flow meter to the pressure and return lines at the front of the excavator
- Set the specified pressure for the Cyclone at the excavator side
- Set the specified oil volume for the Cyclone
- Backup the pre-settings
- Record the setting values
- Disassemble the measuring turbine

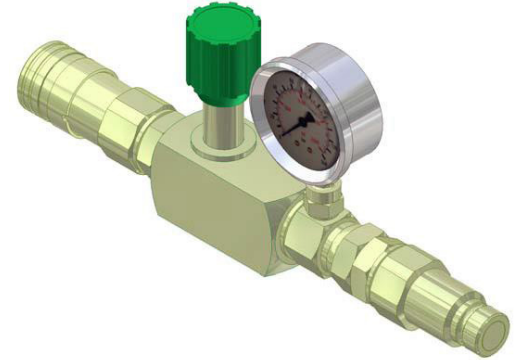

# INSTALLATION

## Prior To Start-Up

1. Measure the flow in the excavator breaker control circuit using a flow meter.
2. Adjust the pressure in the breaker control circuit to the Cyclone. Make sure the flow and pressure do not exceed the Cyclone's nominal output. Based on the flow values, the required maximum pressure can be calculated as specified below.

$$\text{Pressure (in psi)} = \text{Cyclone Power (hp)} \times 600 \text{ (Constant)} / \text{Flow (gallons)}$$

With the Cyclone having a maximum effective output of 147.5 hp and an optimum oil volume of 84.5 gallons, the following pressure setting is obtained.

$$\begin{aligned} \text{Pressure setting at max. oil volume} &= 147.5 \text{ hp} \times 600 / 84.5 \text{ gal} = 2973 \text{ psi} \\ \text{Power calculation after setup} &= \text{pressure (psi)} \times \text{volume (gal)} / 600 = \text{power (hp)} \end{aligned}$$

3. The discharge line must be directly connected to the excavator hydraulic oil reservoir. It must not be connected to another hydraulic line or another hydraulic valve or be subjected to any other restrictions. If this is not possible, please contact the Genesis Service Department.
4. Make sure the Cyclone and adapter plate are firmly assembled to the excavator and all hydraulic hoses and fittings are tightly connected.

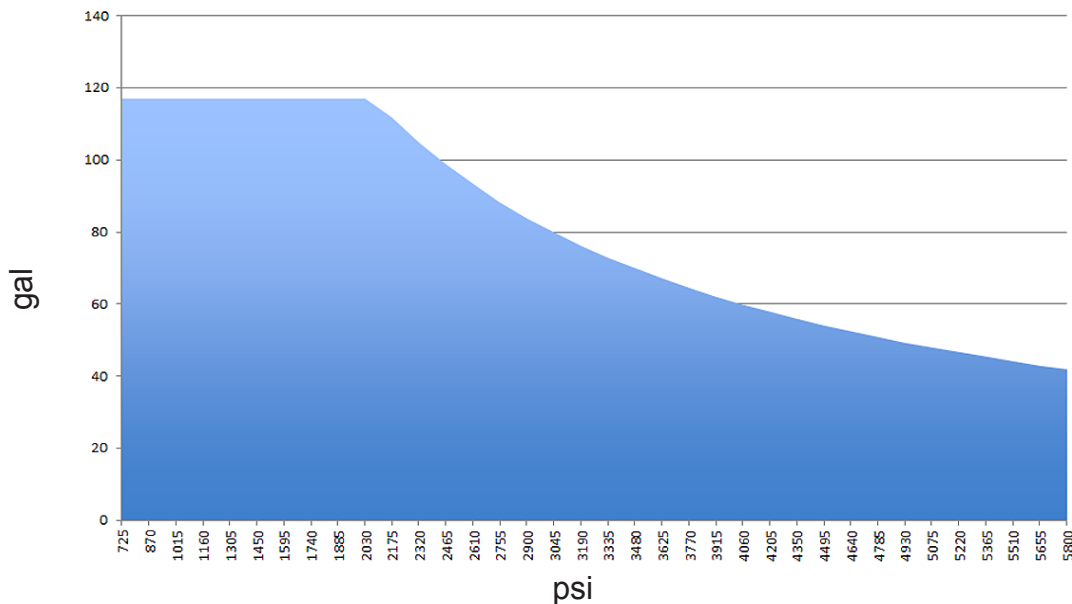

## With the Cyclone Running

Make sure the drums are rotating in the correct direction. If not, switch the hydraulic pressure and return line in the excavator control circuit.

Check the pressure in the motor return line. The pressure must be at least 72 to 145 psi higher than the pressure in the leak oil line.

## DISASSEMBLY & STORAGE

### Disassembly

- Properly disconnect the Cyclone from the excavator
- Drain any liquids as required
- Seal open line ends

### Storage

To keep the Cyclone functional through longer storage periods, follow the below.

- Keep the storage area dry and clean
- Store the Cyclone on an even surface and prevent it from tilting, rolling and unauthorized use
- Clean the Cyclone and apply an acid-free oil to the metal parts to prevent corrosion
- Cover the Cyclone completely to prevent dirt and dust accumulation
- Do not expose the Cyclone to extreme cold or heat

## OPERATING

The Cyclone is suitable for attachment to all conventional hydraulic excavators, per the excavator weight ranges for each model. The Cyclone mounts to the excavator bucket arm via a quick coupler or direct pin-on.

The Cyclone is very powerful and can be used in a variety of applications. It cuts through almost all types of rock, pavement (asphalt), walls (masonry walls made of bricks, concrete, cement), etc. Since the Cyclone operates at full system pressure, the secondary pressure must not be set lower than the system pressure to prevent hydraulic system overheating.

The Cyclone generates less noise than other excavation processes. In free-ranging operation, the A-rated sound power level is below 75 dBA. Depending on the type of material being processed, the sound power level may be above this value. If required, a measurement of continuous sound pressure must be taken and suitable protective measures implemented.

In order to ensure safe operation of the Cyclone, correct handling and proper maintenance and servicing at regular intervals must be observed. Incorrect handling may cause performance impairment.

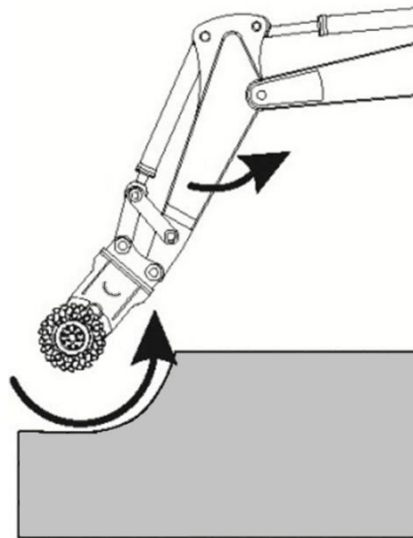

### NOTICE

Optimal operation is only possible if the drum is guided in the direction of the excavator. When swiveling the Cyclone to the sides for reaching long distances, the forces acting on the excavator boom and the Cyclone drum bearings must not be too high.



# APPLICATION EXAMPLES

## Trenches

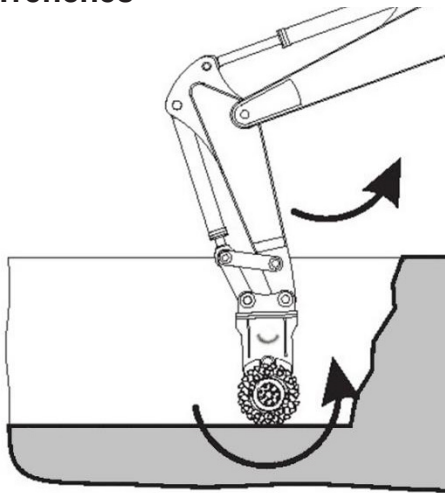

## Asphalt

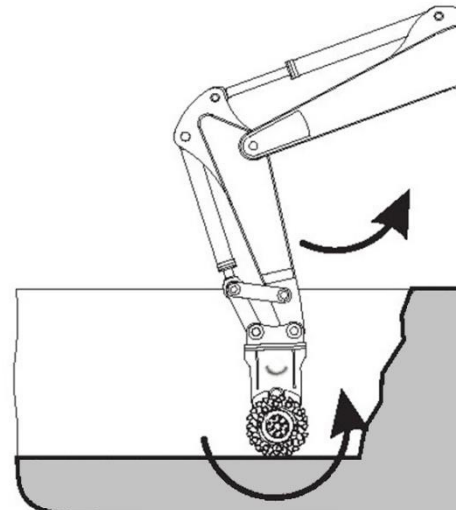

Prevents uncontrolled break-off of large pieces.

## Walls

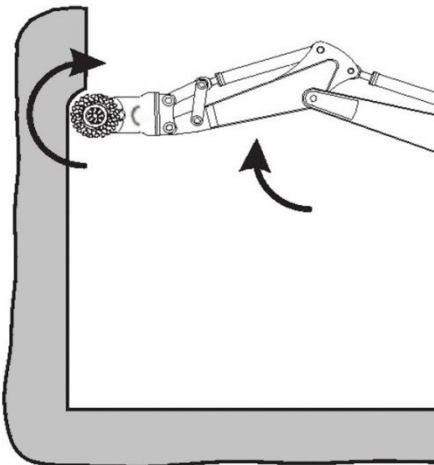

When operating on vertical surfaces, the Cyclo must be turned 180 degrees to reduce vibration and counter-forces during cutting.

## Water



Use of the Cyclo in swampy areas or underwater in depths of up to 98 feet is possible upon conversion. Contact the Genesis Service Department before use.



## DRUM TYPES

Drum and cutting pick selection is dependent upon the operating conditions. However, it is possible to use different drum and pick layouts simultaneously.

### **Rock**

Rock drums are used for cutting rock of low to medium hardness. The picks must be arranged such that they provide the best possible cutting output.

Properties:

- For rock of low to medium hardness
- Picks for maximum productivity and cutting output
- No spiral guard plate that limits cutting depth

### **Profiling**

Profiling drums are used for profiling and smoothing. Since these drums only produce small pieces of rock, they are not suitable for breaking rock.

Properties:

- For rock of low to medium hardness - particularly for accurate or smooth surfaces
- A higher number of picks allows for smoother surfaces and lower vibration; however, the output is also reduced.

### **Demolition**

Demolition drums have a spiral guard plate that limits cutting depth and cuts reinforcement material during demolition work.

Properties:

- For medium-hard to hard rock and concrete
- A wear-protected spiral guard plate limits cutting depth, reduces vibration and allows for smoother operation.

## TECHNICAL DATA

Do not operate the Cyclone with maximum pressure and maximum hydraulic flow at the same time since this exceeds the admissible nominal output. The Cyclone must be operated within the nominal output range.

Maximum Input Power (hp)	147
Maximum Delivery Rate (gpm)	121
Recommended Delivery Rate (gpm)	85
Maximum Pressure (psi)	5,801
Drive Shaft Torque (ft-lb at 5075 psi)	17,178
Pick Force (lbs at 5075 psi)	15,486
Drive Shaft Speed (rpm at 84.7 gpm)	76.2
Pick Speed (ft/s at 84.7 gpm)	8.86
Excavator Weight (lbs)	52,000 - 76,000

### Cutting Drum Dimensions

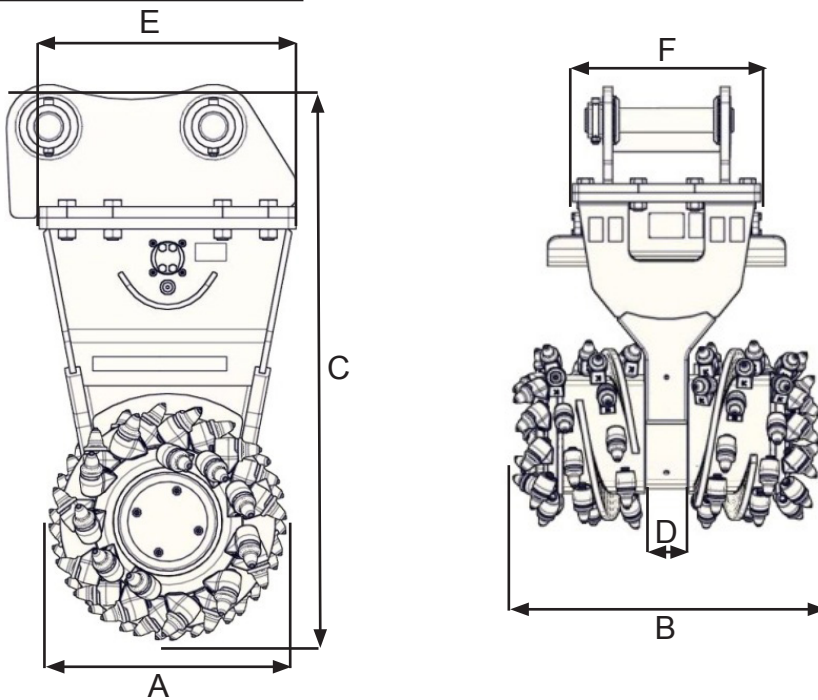

#### **Picks**

- Standard
- Heavy-Duty
- Wear-Protected
- Excavation

A Drum Diameter (in)	B Drum Width (in)	C Height (in)	D Width at the Middle Web (in)	E Connection Plate (in)	F Connection Plate (in)
27	46	46	5.6	27.5	25.6

## MAINTENANCE

The Cyclone must only be serviced by technicians who have been trained in its operation and maintenance.

Prior to servicing, the following maintenance work must be performed and the following torque settings verified.

- Make sure the hydraulic circuit corresponds to the technical description of the Cyclone.
- While running, check the hydraulic oil temperature. It must be between 122°F and 140°F and not exceed 176°F under any circumstances. If the temperature exceeds 176°F, the cooling output must be increased or the power reduced.
- While running, the delivery rate and pressure values must be checked and adjusted as necessary.

Shut down the excavator and secure it against accidental re-start.

### **Cleaning**

Clean the Cyclone with a power washer or steam cleaner, using only water or non-flammable solvents. After cleaning, inspect all supply lines and connections for leaks, loosened connections or fittings, or damage, and repair as necessary. Replace damaged or missing warning labels.

Make sure the picks spin in the holders.

### **Maintenance Schedule**

The specified maintenance intervals are intended as guidelines. Shorter maintenance intervals may be required based upon operating conditions and material processed. These maintenance intervals have been calculated for single-shift operation (8h/day, 20 days/month, 12 months/year). If the machine is operated in multiple shifts, the maintenance intervals must be reduced accordingly.

#### **Daily Prior to Starting Work**

- Check external components for leakage
- Make sure the cutting heads are securely fastened
- Check all screw connections
- Check hoses for tightness and any damage
- Check all picks and pick holders for wear and replace as required

#### **Every 100 Hours**

- Check all screw connections
- Check for internal leakage
- Check cutting drum torque

#### **Every 1000 Hours**

- Check condition of hydraulic motor
- Disassemble cutting drums. Check seals and gaskets for leakage. Check screw connections.
- Check condition of the slide ring packing

## MAINTENANCE

### Pick Replacement

The instructions below must be carefully followed. Failure to do so may void the warranty. Contact the Genesis Service Department for assistance.

Thoroughly clean the Cyclone prior to performing maintenance.  
Position the Cyclone so the cutting drums can be easily rotated.



## WARNING

Crushing hazard - secure the Cyclone to prevent from sliding and falling.

### Disassembly of a Pick with Retaining Ring

Installation and disassembly tools

Wedge

Installation/disassembly tool

Reaming tool



Break up the C-retaining ring using a hammer. Use the installation tool for the securing ring.



Knock the pick out of the holder using a hammer and a reaming tool.



Loosen any stuck picks by driving the wedge into the gap between the pick and the holder.

Repeat the process to remove all picks.



## WARNING

Always wear eye protection when performing maintenance.

## MAINTENANCE

### Pick Installation

Before installing a new pick, clean the hole in the pick holder. Slide the pick into the holder.

Before installing used picks, clean the shank.

Do not use lubricant, grease or oil, when installing the picks.



### Assembly of a Pick with C-Retaining Ring

Insert the C-retaining ring into the pick slot.

Insert the securing ring installation tool into the groove and subsequently knock in the C-retaining ring using a hammer until it is secure.

Repeat for all picks.



## NOTICE

Before performing any cutting work, correct fit of all picks and C-rings must be verified. The picks must rotate freely within the holders.

## MAINTENANCE

### Checking the Slide Ring Packing

To avoid compromising the warranty, please contact the Genesis Service Department before checking for leakage or performing the following steps.

- Shut down the excavator
- Remove the cutting drums
- Remove the end plate
- At the removed end plate, check if the slide ring packing is damaged or leaking.
- Check the housing for leakage
- Check if appropriate venting port is present
- Check the tightening torque of the M16 socket head screws. The torque value must be 244 ft-lbs.
- In case of leakage or if the tightening torque is not reached, please contact the Genesis Service Department.

Remove the end plate and packing carrier, check the slide ring packing. Tighten torque of the M16 socket head screws.

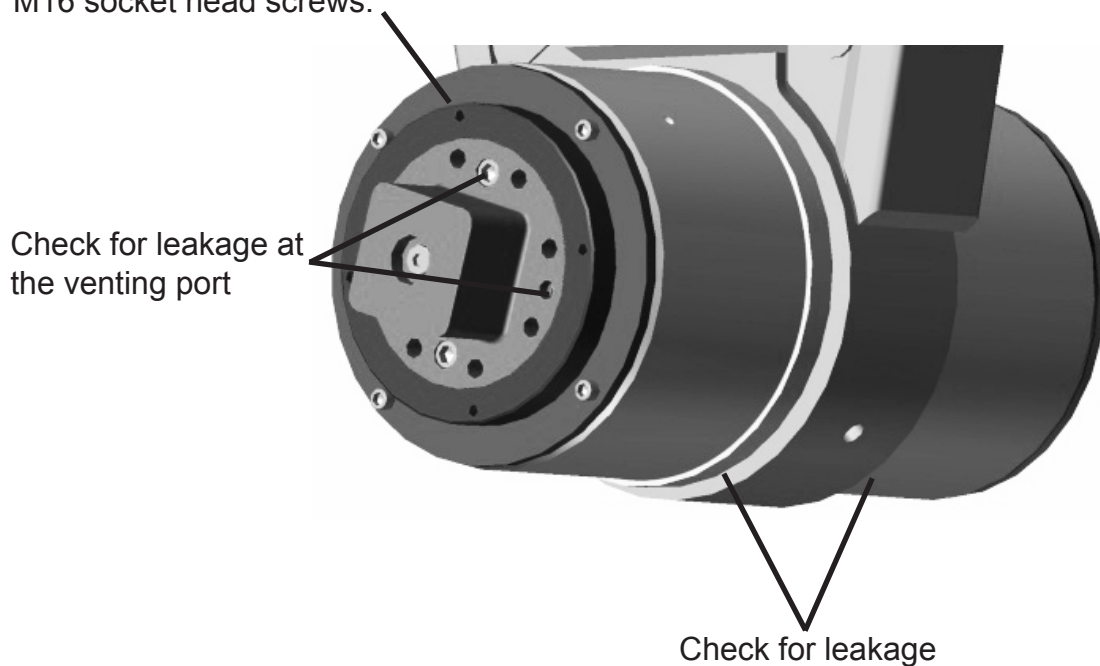

## MAINTENANCE

### Cutting Drum Removal/Installation

To avoid compromising the warranty, please contact the Genesis Service Department before removing/installing the cutting drum or performing the following steps.

- Shut down the excavator
- Remove the four M16 x 40 socket head screws to disassemble the cutting drum cover
- Remove the eight M20 x 90 socket head screws
- If required, mount a suitable spacer unit to the end of the shaft using four M16 bolts and position the cutting drum on the ground.
- The cutting drum center of gravity is approximately at pick number seven. Every sling or chain used for transport must be placed around this point.
- Carefully lift the cutting drum. Make sure the drive is not damaged.
- New M20 x 90 socket head screws must be used when installing the cutting drum. Tighten these screws to a torque of 480 ft-lbs. to prevent damage to the square socket head screw.

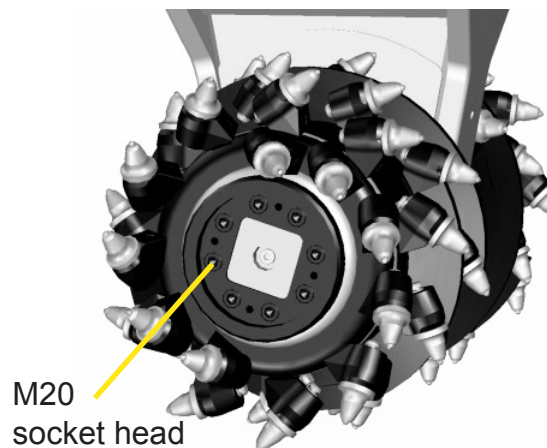
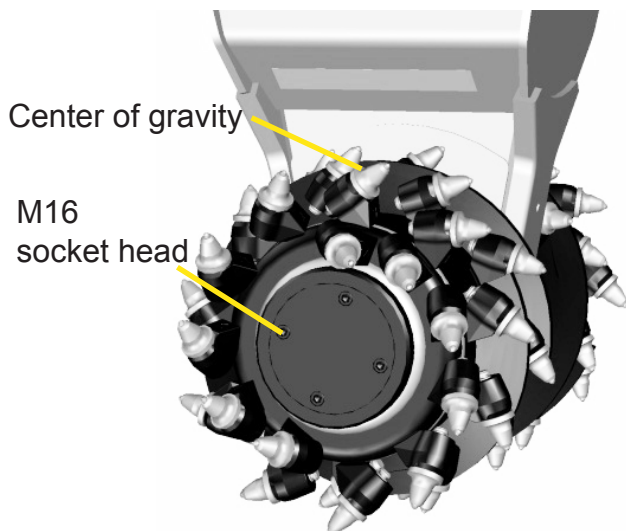



## MAINTENANCE

### Hydraulic Motor Flushing/Filling

The Cyclone must only be serviced by technicians who have been trained in its operation and maintenance.

To avoid compromising the warranty, please contact the Genesis Service Department before flushing/filling the hydraulic motor or performing the following steps.

The Cyclone has been filled with oil prior to delivery and must only be refilled in cases of leakage.

- Shut down the excavator
- Remove the cover on both sides to expose the ½ inch BSP connectors
- Remove the two connectors
- Disconnect the return line from the excavator and remove the quick coupler if used
- Connect a hose to the right side drum by the ½ inch BSP connector
- Fill with oil until oil runs out of the BSP connector on the opposite side. Make sure the oil running out is clean.
- Clean the connection
- The oil amount is sufficient if oil flows back through the return line or the discharge line.

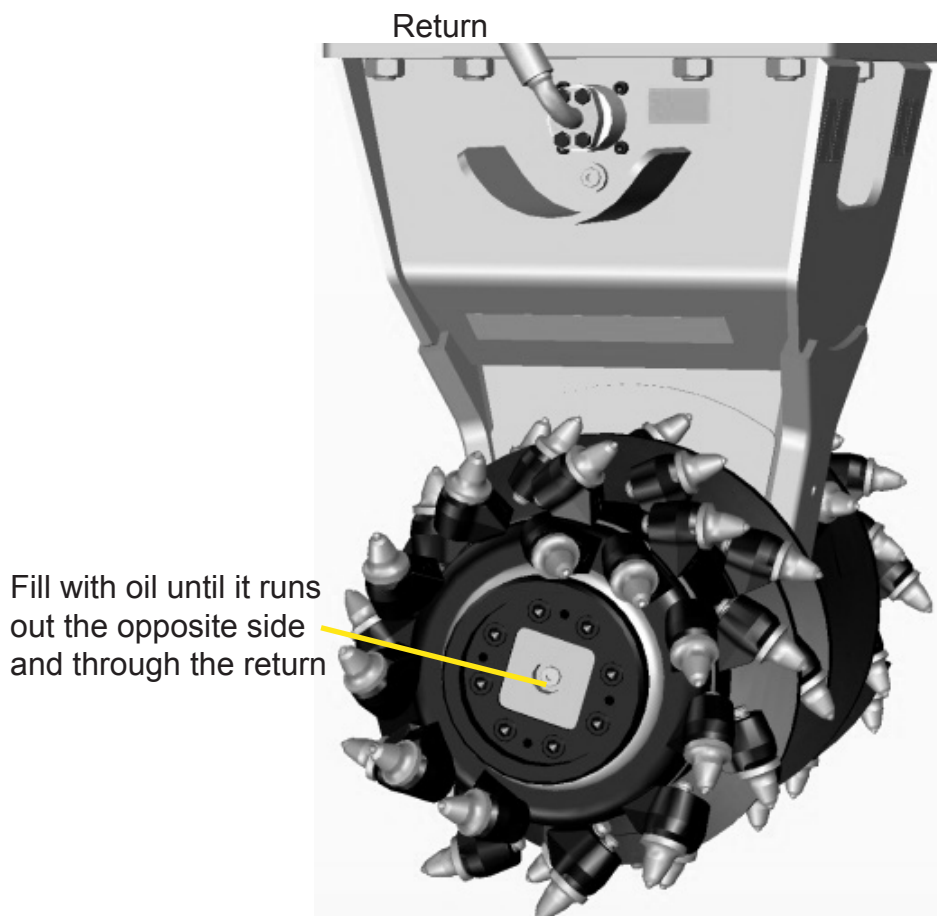



## MAINTENANCE

### Check Hydraulic Motor Condition

To avoid compromising the warranty, please contact the Genesis Service Department before checking the motor or performing the following steps.

- Shut down the excavator and allow the hydraulic oil to cool
- Remove the cover on both sides to expose the ½ inch BSP connectors
- Remove the connector, connect a suitable hose and put the end into a bucket
- Set the cutting head to a blocked condition by shutting down the return
- Start the Cyclone
- Monitor the oil flow rate through the discharge line. It should not be more than 1 gpm.
- If a leak oil line is used, check it using a measuring device.

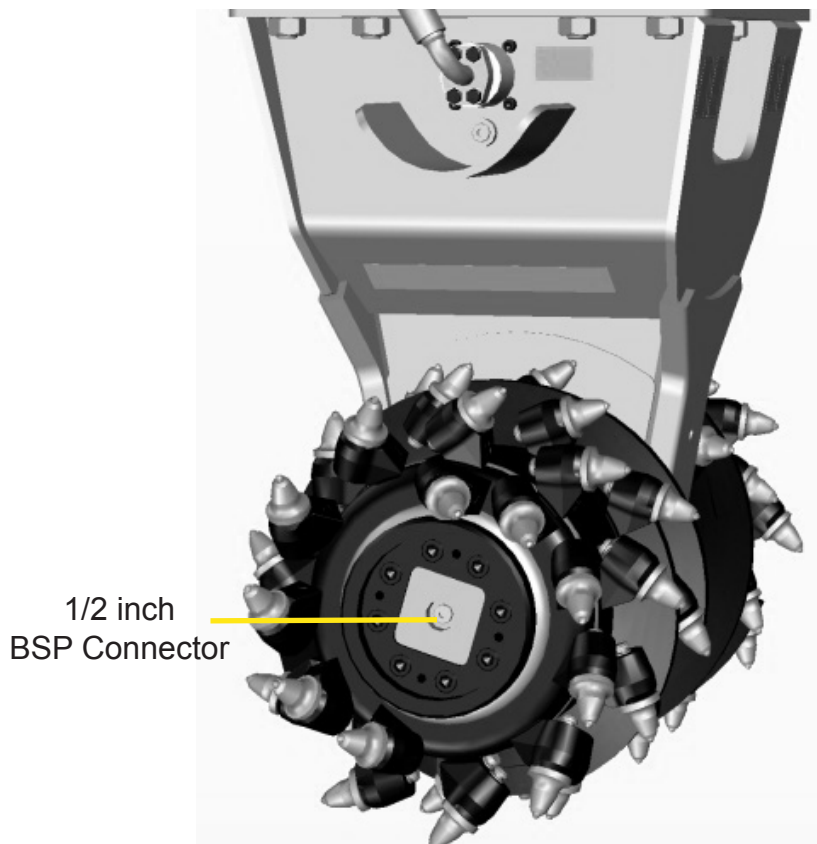

# TROUBLE-SHOOTING GUIDE

## Cutting Performance Declines

Inspect	Possible Causes/Solutions
All picks and holders for wear	A pick must be replaced if the hard metal insert has been lost or damaged. The holders must be replaced if they are damaged.
	Picks and/or holders must be replaced/repared if the cutting head holder is worn.
The excavator hydraulic circuit	The Cyclone output depends on the correct functioning of the excavator hydraulic circuit.
	Remove the Cyclone from the hydraulic circuit. Check the flow, overpressure and hydraulic pressure. The higher the main pressure connection, the better the cutting output. The ideal setting is 4641 psi.
Tightness of the external supply line	Oil will leak if the return line pressure is higher than 725 psi. For optimum performance, the Cyclone requires a direct return into the reservoir. Make sure the return line is not clogged.
Make sure the pressure between supply and return is not higher than 725 psi	Excessive pressure may result in mechanical problems. Remove the cutting drums, hoses and quick couplers. Try to rotate the drive shaft using a suitable lever. If the shaft does not rotate, the Cyclone must be disassembled for inspection.
Check the speed of the cutting heads in connection with the flow (10 rpm = 11 gpm)	The correct flow rate may not be achieved due to a defective valve or a worn hydraulic motor. Check the motor. If motor leakage is within the specified limits, the issue is likely due to a defective start-up valve.
The hydraulic motor	If the motor is worn, oil may leak at the pistons, reducing the cutting output. Contaminated oil and/or low oil viscosity and too high flow rates are the main reasons for motor failure. The motor must be replaced. Contact Genesis.

## Cutting Drums Do Not Rotate

The excavator hydraulic circuit	The Cyclone output depends on the correct functioning of the excavator hydraulic circuit.
	Remove the Cyclone from the hydraulic circuit. Check the flow, overpressure and hydraulic pressure. Also check all hydraulic hoses/tubes, molded parts and quick couplers.
The supply line pressure	Excessive pressure may result in mechanical problems. Remove the cutting drums, hoses and quick couplers. Try to rotate the drive shaft using a suitable lever. If the shaft does not rotate, the Cyclone must be disassembled for inspection.

# TROUBLE-SHOOTING GUIDE

## Oil Leakage at External Components

Inspect	Possible Causes/Solutions
The excavator hydraulic circuit	Oil will leak if the return line pressure is higher than 725 psi. For optimum performance, the Cyclone requires a direct return into the reservoir.
	Remove the Cyclone from the hydraulic circuit. Check the flow, overpressure and hydraulic pressure. Also check all hydraulic hoses/tubes, molded parts and quick couplers.
The hydraulic motor	If the motor is worn, oil may leak at the pistons, reducing the cutting output. Contaminated oil and/or low oil viscosity and too high flow rates are the main reasons for motor failure. The motor must be replaced. Contact Genesis.

## Oil Leakage

Oil leaks out between the adapter plate and the Cyclone fastening surface	A number of hoses and fittings installed in this area may be damaged. Remove the adapter plate to obtain access to the leakage area.
Oil leaks out between the cutting head and the housing	Oil may leak from the fastening screws, mounting surface between the housing and bearing housing, and/or venting port
	Remove the cutting head and find the leakage point.
	<p>If the leakage is caused by loose screws, remove the 4 M12x25 screws and the end plate to obtain access to the M16x160 or M16 x 200 screws. Make sure they are tightened to 244 ft-lbs.</p> <p>If the leakage is at the mounting surface between the housing and bearing housing, remove the bearing housing and check if the O-ring is defective.</p> <p>If the leakage is at the venting port, check if the shaft gasket is defective.</p>

## Only One Cutting Drum Rotates

Only one cutting drum rotates or rotates faster than the other	There is a problem with the internal shaft, and the Cyclone must not be used. Complete disassembly is required. Contact Genesis.
--	--

## WARRANTY

### **Claim Procedure**

Notify the Genesis Service Department of the potential warranty claim prior to making the repair. Digital pictures are very helpful for diagnosing problems and recommending repairs.

Contact the Genesis Service Department before making alterations, changes or repairs to any component that is going to be considered for warranty. Not doing so will void all Genesis warranty consideration.

The Genesis Service Department will issue an authorization number to track the repair costs, outgoing parts, and/or defective parts returning to the factory.

Replacement parts must be ordered using a purchase order number. Shipping is standard ground. Overnight shipping is available by request, and Genesis will not cover the shipping charge.

When the repair is complete, submit an invoice to the Genesis Service Department within 30 days. Include itemized internal labor reporting, parts lists and invoices for outside contractors. Reference the authorization number on all invoices.

When returning parts for warranty consideration, include a copy of any related Genesis paperwork along with any other necessary documentation to ensure proper processing and credit. The Genesis Service Department will provide the necessary forms.

Your account will be credited when the warranty claim is accepted.

**Please direct any questions to the Genesis Service Department: 715-395-5252**

# PARTS ORDER POLICY AND PROCEDURE

## **Parts Orders Should Include**

- Purchase order number
- Model and serial number of attachment
- Part number and quantity needed
- Shipping and billing address
- Method of shipment or required delivery date

## **Placing Orders**

Orders may be placed by phone, e-mail or fax. To fax an order, use the form on the following page. Contact information is located at the front of this manual.

## **Part Numbers**

Part numbers are listed in a separate Parts Manual or, if included, the Parts section of this manual. Contact the Genesis Parts Department with questions regarding part numbers, availability and pricing.

## **Shipping**

All orders will be shipped best way surface unless an alternate shipping method is requested. Shipping charges are not included in the purchase price of parts.

## **Invoices**

All invoices are due upon receipt. Any accounts with invoices open beyond 60 days are subject to review and may be placed on C.O.D. status without further notice.

## **Returns**

Unused Genesis parts may be returned with proper documentation. Return shipping is the responsibility of the purchaser. Credit will be issued upon return, less a 20% restocking fee. Documentation is required for credit of returned parts. Contact the Genesis Parts Department at 715-395-5252 for a RGA (Return Goods Authorization) number and form.

## **Return Goods Authorization**

All parts returned to Genesis for warranty consideration must be returned with a completed RGA (Return Goods Authorization) provided by the Genesis Parts Department. The form needs to be completed in its entirety, including any additional information requested by the Parts or Service Department. Return freight is the responsibility of the shipper and will be credited upon claim approval. A determination to accept or deny the claim will be made based on the information available to Genesis. Warranty on purchased parts other than wear components is 6 months. There is no warranty period on wear parts or components.

# PARTS ORDER FORM

Customer: \_\_\_\_\_ Date: \_\_\_\_\_

Phone: \_\_\_\_\_ Contact: \_\_\_\_\_

Shipping Address: \_\_\_\_\_ E-mail: \_\_\_\_\_

\_\_\_\_\_  
Billing Address: \_\_\_\_\_

\_\_\_\_\_  
\_\_\_\_\_

Purchase Order: \_\_\_\_\_ Shipping Method: \_\_\_\_\_

Model: \_\_\_\_\_ Serial Number: \_\_\_\_\_

Quantity	Part Number	Description	Price

E-mail to the Genesis Parts Department: [genesisparts@genesisattachments.com](mailto:genesisparts@genesisattachments.com)  
For assistance, call 715-395-5252



**GENESIS®**

The Promise of Performance.

## CONTACT INFORMATION

### Genesis Attachments

1000 Genesis Drive  
Superior, WI 54880 USA

Toll Free: 888-SHEAR-IT  
(888-743-2748)

Phone: 715.395.5252

E-mail:  
info@genesisattachments.com

### Europe/Africa/Middle East Genesis GmbH

Teramostrasse 23  
87700 Memmingen, Germany

Phone: +49 83 31 9 25 98 0

Fax: +49 83 31 9 25 98 80  
genesis-europe.com

E-mail:  
info@genesis-europe.com

### Asia Pacific Representative Office

24 Upper Serangoon View #12-28  
Singapore 534205

Phone: +65 9673 9730

E-mail:  
tchoo@genesisattachments.com

### Central America & Colombia

Cra 13A #89-38 / Ofi 613  
Bogota, Colombia

Phone: +57 1 610 8160 / 795 8747

E-mail:  
contact@themsagroup.com

View and download all manuals: [genesisattachments.com/manuals](http://genesisattachments.com/manuals)  
Patents: [genesisattachments.com/products/patents](http://genesisattachments.com/products/patents)

Rev. C - 8-19-19