

**GENESIS**<sup>®</sup>

The Promise of Performance.

# GMP C Series Mechanical Pulverizer

**SAFETY, OPERATOR'S & PARTS MANUAL**

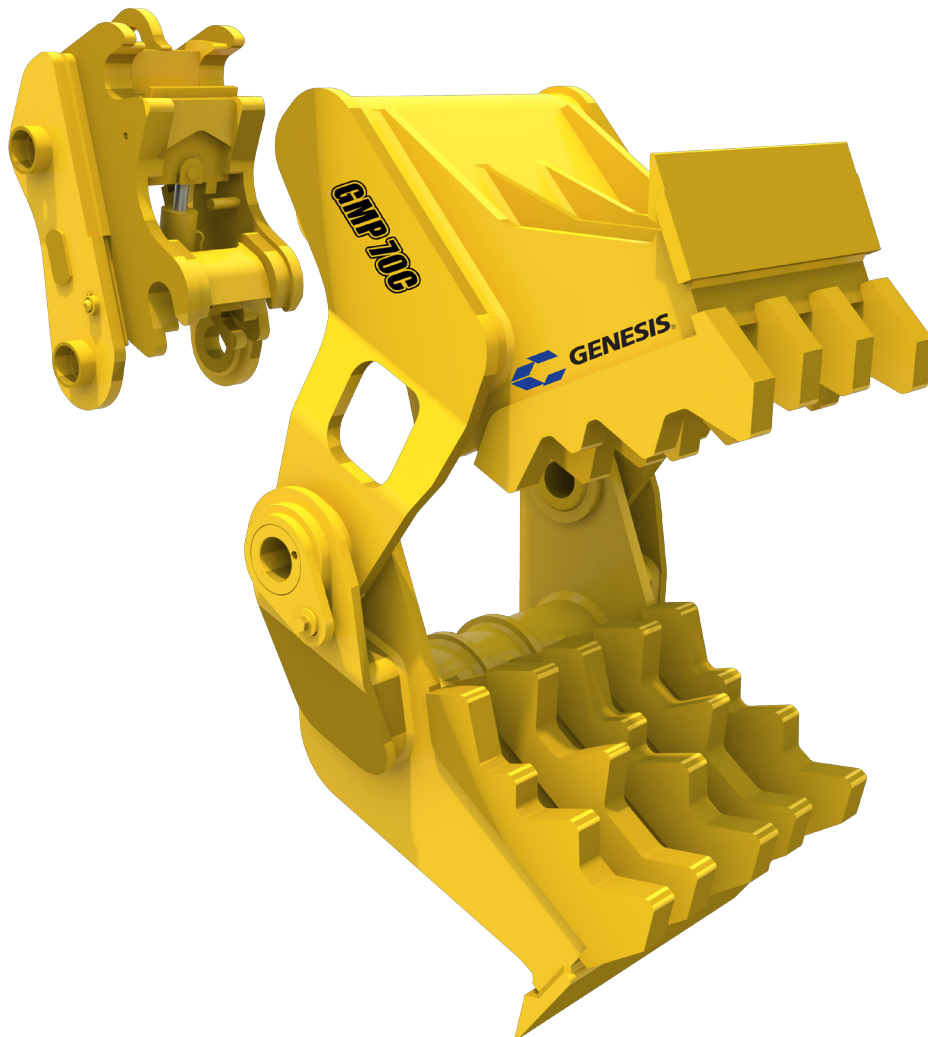

## CONTACT INFORMATION

### **World Headquarters Genesis Attachments**

1000 Genesis Drive  
Superior, WI 54880 USA

Toll Free: 888-SHEAR-IT  
(888-743-2748)

Phone: 715.395.5252  
Fax: 715.395.5255

E-mail:  
info@genesisattachments.com

### **Europe/Africa/Middle East Genesis GmbH**

Teramostrasse 23  
87700 Memmingen, Germany

Phone: +49 83 31 9 25 98 0  
Fax: +49 83 31 9 25 98 80  
genesis-europe.com

E-mail:  
info@genesis-europe.com

### **Asia Pacific Representative Office**

24 Upper Serangoon View #12-28  
Singapore 534205

Phone: +65 9673 9730

E-mail:  
tchoo@genesisattachments.com

### **Central & South America, The Caribbean**

Cra 13A #89-38 / Ofi 613  
Bogota, Colombia

Phone: +57 1 610 8160 / 795 8747

E-mail:  
contact@themsagroup.com

### **Brazil**

Avenida Araça, 1677  
Campinas - São Paulo

Phone: +55 19 9 9989-8803

E-mail:  
gel@themsagroup.com

View and download all manuals at [genesisattachments.com/manuals.asp](http://genesisattachments.com/manuals.asp)  
Patents: [genesisattachments.com/patents](http://genesisattachments.com/patents)

## PREFACE

To ensure years of safe, dependable service, only trained and authorized persons should operate and service your Genesis attachment. It is the responsibility of the product's owner to ensure the operator is trained in the safe operation of the product and has available this manual for review. It is the responsibility of the operator and maintenance personnel to read, fully understand and follow all operational and safety-related instructions in this manual. The attachment should not be operated until you have read and fully understand these instructions. Always use good safety practices to protect yourself and those around you.

### **Important**

This operator's manual must accompany the attachment at all times and be readily available to the operator.

### **Manual Replacement**

Should this manual become damaged or lost or if additional copies are required, immediately contact any authorized Genesis dealer or the Genesis Service Department at 888-743-2748 or 715-395-5252 for a replacement.

### **Registration Form**

The Warranty Registration Form must be filled out by the dealer or customer and returned to Genesis indicating the date the attachment went into service.

### **Possible Variations**

Genesis cannot anticipate every possible circumstance that might involve a potential hazard as the owner's requirements and equipment may vary. Therefore, the warnings in this publication and on the product may not be all-inclusive, and you must satisfy yourself that the procedure, application, work method or operating technique is safe for you and others before operating.

### **Public Notice**

Genesis reserves the right to make changes and improvements to its products and technical literature at any time without public notice or obligation. Genesis also reserves the right to discontinue manufacturing any product at its discretion at any time.

### **Warranty**

All work or repairs to be considered for warranty reimbursement must be pre-authorized by the Genesis Service Department. Any alterations, modifications or repairs performed before authorization by the Genesis Service Department will render all warranty reimbursement consideration null and void without exception. See page 29 for Warranty Claim Procedures.

Improper operation or improperly performed maintenance may render any warranty null and void.

# TABLE OF CONTENTS

<b>CONTACT INFORMATION</b>	<b>2</b>
<b>PREFACE</b>	<b>3</b>
Important	3
Manual Replacement	3
Registration Form	3
Possible Variations	3
Public Notice	3
Warranty	3
<b>NOTES</b>	<b>6</b>
<b>SAFETY STATEMENTS</b>	<b>7</b>
<b>OPERATIONAL SAFETY</b>	<b>8</b>
Read Manual Before Operating or Maintaining the Attachment	8
Personal Protection	8
Know Your Equipment	8
Before Operating	8
Check the Equipment	9
Stability	9
Know the Work Area	10
Starting Procedure	10
Place the Load Safely	10
Safely Operate Equipment	11
Transporting the Attachment	12
Equipment Condition	12
Working Overhead	12
Power Lines	12
Use Care with Hydraulic Fluid Pressure	13
Prioritized Oil Flow	14
Emergency Situations	14
Unsafe Conditions	14
Crystalline Silica Dust	14
Process Material Safely	15
Lift the Load Safely	15
Place the Load Safely	15
<b>PROCESSOR MARKINGS</b>	<b>16</b>
<b>NOTES</b>	<b>17</b>
<b>PROCESSOR INSTALLATION</b>	<b>18</b>
Pad Installation	18
Processor Installation	19
Removal	19
<b>MAINTENANCE SAFETY</b>	<b>20</b>
<b>MAINTENANCE SCHEDULE</b>	<b>21</b>
Eight-Hour Checklist	21
<b>BOLT TORQUE SPECIFICATIONS</b>	<b>22</b>
<b>JAW MAINTENANCE</b>	<b>24</b>
Pulverizing Teeth	24

# TABLE OF CONTENTS

<b>GENERAL WELDING GUIDELINES</b> .....	<b>25</b>
Welding Ground Clamp.....	25
Welding Rules.....	25
<b>HARD-SURFACING</b> .....	<b>26</b>
<b>HARD-SURFACING PATTERNS</b> .....	<b>27</b>
<b>TROUBLE-SHOOTING GUIDE</b> .....	<b>28</b>
<b>WARRANTY</b> .....	<b>29</b>
Claim Procedure.....	29
Blade Warranty.....	29
<b>PARTS ORDER POLICY AND PROCEDURE</b> .....	<b>30</b>
Parts Orders Should Include.....	30
Placing Orders.....	30
Part Numbers.....	30
Shipping.....	30
Invoices.....	30
Returns.....	30
Return Goods Authorization.....	30
<b>PARTS ORDER FORM</b> .....	<b>31</b>
<b>PARTS</b> .....	<b>32</b>
Wear Parts.....	33
<b>CONTACT INFORMATION</b> .....	<b>34</b>

# NOTES

## SAFETY STATEMENTS



This symbol by itself or used with a safety signal word throughout this manual is used to call attention to instructions involving your personal safety or the safety of others. Failure to follow these instructions can result in injury or death.



This statement is used where serious injury or death will result if the instructions are not followed properly.



This statement is used where serious injury or death could result if the instructions are not followed properly.



This statement is used where minor or moderate injury could result if the instructions are not followed properly.

**NOTICE**

This statement is used where property damage could result if the instructions are not followed properly.

## OPERATIONAL SAFETY

### Read Manual Before Operating or Maintaining the Attachment



Read this manual before attempting to operate the attachment. This operator's manual should be regarded as part of the attachment. For proper installation, operation and maintenance of the attachment, operators and maintenance personnel must read this manual.



### **WARNING**

Serious injury or death could result if appropriate protective clothing and safety devices are not used.

### Personal Protection

Use protective clothing and safety devices appropriate for the working conditions. These may include but are not limited to:

- ✓ Hard hat
- ✓ Safety glasses, goggles or face shield
- ✓ Hearing protection
- ✓ Safety shoes
- ✓ Heavy gloves
- ✓ Reflective clothing
- ✓ Respirator or filter mask



# Safety matters

### Know Your Equipment



Know your attachment's capabilities, dimensions and functions before operating. Inspect your attachment before operating and never operate an attachment that is not in proper working order. Remove and replace any damaged or worn parts.

### Before Operating

- ✓ Warn all others in the area that you are about to start operation.
- ✓ Perform the "Check the Equipment" steps outlined in this manual.
- ✓ Check underneath and around the machine. Make sure all personnel and equipment are clear from the area of operation and equipment movement. Check clearances in all directions, including overhead.
- ✓ Be properly seated in the operator's seat.
- ✓ Do not attempt to operate until you have read and fully understand this manual and the OEM manual for the carrier.



## OPERATIONAL SAFETY

### Check the Equipment

Before use, check the equipment to ensure it is in good operating condition.

Check the following:

- ✓ Grease fittings. Pump grease at all fitting locations. See page 21
- ✓ Hydraulic fluid level. Add hydraulic fluid as required.
- ✓ Hydraulic hoses and hose connections for wear or leaks. Repair or replace any damaged hoses or connections.
- ✓ All control levers for proper operation.
- ✓ Check for loose or missing pin retaining bolts.



**GOOD  
CONDITION**



**WARNING**

Serious injury or death could result if warnings or instructions regarding carrier stability and the work area are not followed properly.

### Stability

Your Genesis attachment is sized for carrier stability. However, improper operation, faulty maintenance or unauthorized modifications may cause instability.

- ✓ Know the working ranges and capacities of the carrier to avoid tipping.
- ✓ Use the recommended carrier counter weight.

The following conditions affect stability:

- Ground conditions
- Grade
- Weight of attachment
- Contents of attachment
- Operator judgement



For greater stability, knuckle the attachment to bring the load closer to the center of rotation (center of gravity) while lifting. Use extra caution during reaching to avoid tipping.

## OPERATIONAL SAFETY

### **Know the Work Area**

Check clearances in the work area. Keep all bystanders at a safe distance. Do not work under obstacles. Always check your location for overhead and buried power lines or other utilities before operation.

Check ground conditions. Avoid unstable or slippery areas. Position the carrier on firm level ground. If level ground is not possible, position the carrier to use the attachment to the front or back of the carrier. Avoid working over the side of the carrier.

To reduce the risk of tipping and slipping, never park on a grade exceeding 10% (one-foot rise over the span of a ten-foot run).

### **Starting Procedure**

Before operating, walk completely around the equipment to make certain no one is under it, on it or close to it. Keep all bystanders at least 75 feet away from the area of operation and equipment movement. Let all other workers and bystanders know you are preparing to start. DO NOT operate until everyone is clear.

Always be properly seated in the operator's seat before operating any carrier controls.

#### **To start:**

- ✓ Make sure all controls are in the center (neutral) position.
- ✓ Be properly seated.
- ✓ Slowly operate all functions to check for proper operation and to bleed air from the hydraulic system.

#### **To shut down:**

- ✓ Return your Genesis attachment to a rest position on the ground.
- ✓ Shut off the carrier engine.
- ✓ Work controls in all directions to relieve hydraulic pressure, per excavator manufacturer's instructions.



## **WARNING**

Serious injury or death could result if warnings or instructions regarding safe operation are not followed properly.

### **Place the Load Safely**

Do not move the attachment, or anything held in the jaws, over people, equipment or buildings. Do not throw or drop the contents. Operate the controls smoothly and gradually.

## OPERATIONAL SAFETY

### Safely Operate Equipment

Do not operate equipment until you are trained by a qualified operator in its use and capabilities.

See your carrier's manual for these instructions.

- ✓ Operate only from the operator's seat. Check the seat belt daily and replace if frayed or damaged.
- ✓ Do not operate this or any other equipment under the influence of drugs or alcohol. If you are taking prescription medication or over-the-counter drugs ask your medical provider whether you can safely operate equipment.
- ✓ Never leave equipment unattended with the engine running or with the attachment in a raised position. Apply the brakes before exiting the equipment.
- ✓ Do not exceed the lifting capacity of your carrier.
- ✓ Avoid conditions that can lead to tipping. The carrier can tip when operated on hills, ridges, banks and slopes. Avoid operating across a slope which could cause the carrier to overturn.
- ✓ Reduce speed when driving over rough terrain, on a slope, or when turning to avoid overturning the carrier.
- ✓ Never use the attachment as a work platform or personnel carrier.
- ✓ Keep all step plates, grab bars, pedals and controls free of dirt, grease, debris and oil.
- ✓ Never allow anyone to be around the equipment when it is operating.
- ✓ Do not operate poorly maintained or otherwise faulty equipment. Inform the proper authority and DO NOT resume operation until the problem has been fixed.
- ✓ Do not alter or remove any safety features.
- ✓ Know your work site safety rules as well as traffic rules and flow. When in doubt on any safety issue, contact your supervisor or safety coordinator for an explanation.
- ✓ A heavy load can cause equipment instability. Use extreme care during travel. Slow down on turns and watch out for bumps. The equipment may need additional counter-weights to counterbalance the weight of the attachment.



## OPERATIONAL SAFETY

### Transporting the Attachment

- ✓ Travel only with the attachment in a safe transport position to prevent uncontrolled movement. Drive slowly over rough ground and on slopes.
- ✓ When driving on public roads use safety lights, reflectors, Slow Moving Vehicle signs, etc., to prevent accidents. Check local government regulations that may affect you.
- ✓ Do not drive close to ditches, excavations, etc., as cave-in could result.
- ✓ Do not smoke when refueling the prime mover. Allow room in the fuel tank for expansion. Wipe up any spilled fuel. Secure cap tightly when done.

### Equipment Condition

Never operate poorly maintained equipment. When maintenance is required, repair or replace parts immediately.



**WARNING**

Serious injury or death could result if warnings or instructions regarding working overhead are not followed properly.

### Working Overhead

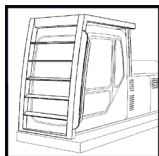

Avoid handling material overhead whenever possible. Safety glass and wire mesh cab guarding must be installed to protect the operator from flying debris that may be created during handling. Falling Object Protection Structures, or FOPS, are necessary for any application where material is to be handled overhead.



**DANGER**

Serious injury or death will result if warnings or instructions regarding power lines are not followed properly.

### Power Lines

Do not operate the machine near energized power lines. All local, state/provincial and federal regulations must be met before approaching power lines, overhead or underground cables, or power sources of any kind with any part of the carrier or attachment. Always contact the appropriate utility when operating near power lines. The lines should be moved, insulated, disconnected or de-energized and grounded before operating in the area.



Current in high voltage lines may arc some distance from the wire to a nearby ground. Keep all parts of the machine at least 50 feet (16m) away from power lines.

## OPERATIONAL SAFETY



### WARNING

Serious injury or death could result if warnings or instructions regarding hydraulic fluid pressure are not followed properly.

#### Use Care with Hydraulic Fluid Pressure

Hydraulic fluid under pressure can penetrate the skin and cause serious injury or death. Hydraulic leaks under pressure may not be visible.

- ✓ Keep unprotected body parts, such as face, eyes and arms as far away as possible from a suspected leak. Flesh injected with hydraulic fluid may develop gangrene or other permanent injuries.
- ✓ If injured by injected fluid see a doctor immediately.
- ✓ Wear safety glasses and protective clothing and use a piece of cardboard or wood when searching for hydraulic leaks.

**Do Not Use Your Hands!**  
**See illustration below.**

- ✓ Hydraulic oil becomes hot during operation. Do not let hydraulic oil or components contact skin, as it could cause severe burns. Allow hydraulic components to cool before working on them. Use appropriate protective clothing and safety equipment. If burned, seek immediate medical attention.

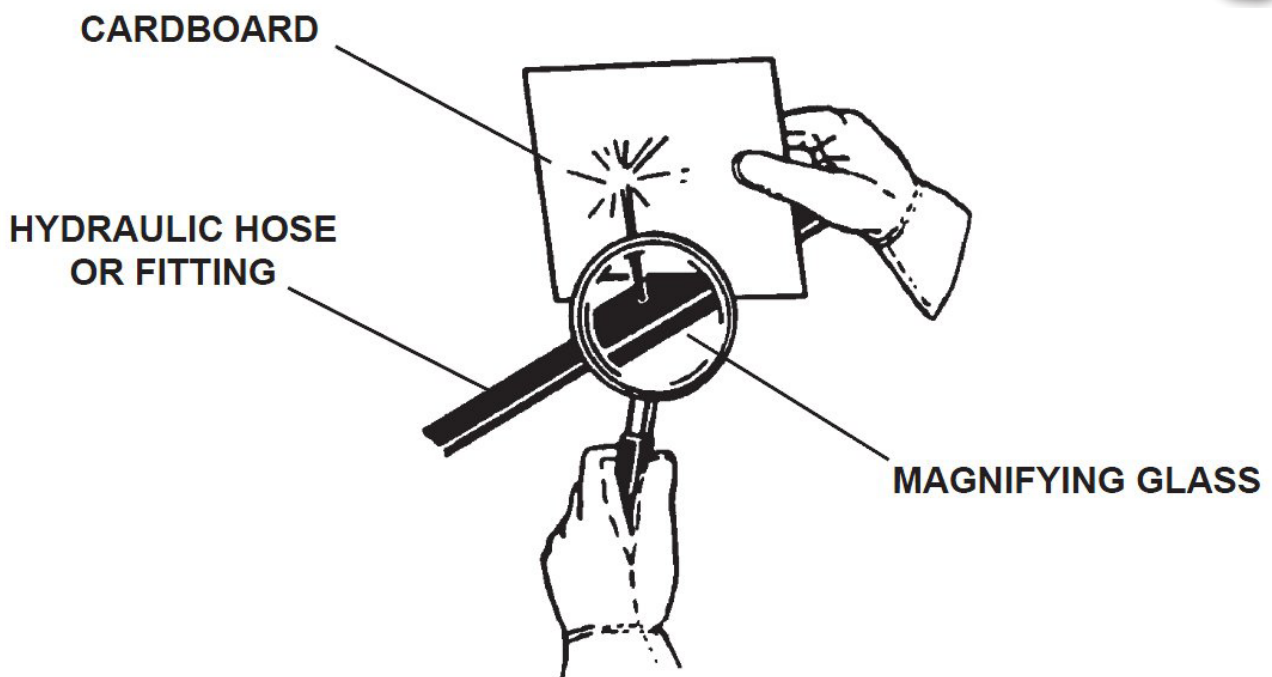

## OPERATIONAL SAFETY

### Prioritized Oil Flow

Equipment operators must ensure there is prioritized oil flow to the main valves in overhead operations or high reach conditions.

### Emergency Situations

Always be prepared for emergencies. Make sure a fire extinguisher is available. Be familiar with its operation. Make sure to inspect and service the fire extinguisher regularly. Make sure a first aid kit is readily available.



### Unsafe Conditions

Do not operate if an unsafe condition exists. Stop operation immediately, shut down the machine and report the unsafe condition to the proper authority. Equipment operation and maintenance practices directly affect your safety and the safety of those around you. Always use common sense while operating and be alert to unsafe conditions.

### Crystalline Silica Dust

It is recommended to use dust suppression, dust collection and if necessary, personal protective equipment during the operation of any attachment that may cause high levels of dust.



**DANGER**

Exposure to respirable crystalline silica dust along with other hazardous dusts may cause serious or fatal respiratory disease.

**IMPORTANT:** Concrete and masonry products contain silica sand. Quartz, which is a form of silica and the most common mineral in the Earth's crust, is associated with many types of rock.

Some activities that may have silica dust present in the air include demolition, sweeping, loading, sawing, hammering, drilling or planing of rock, concrete or masonry.

It is recommended to use dust suppression (such as water) or dust collection (such as a vacuum) along with personal protective equipment if necessary during the operation of any attachment that may cause high levels of silica dust.



## OPERATIONAL SAFETY



Using your Genesis attachment in unauthorized applications may create an unsafe situation and will void the warranty.

### **Process Material Safely**

- Do not process hardened steel material such as tool steel, railroad rail, axles or machined parts. Hardened material breaks, rather than shears, which may cause flying debris. It will also cause damaging decompression spikes to your Genesis attachment and base carrier hydraulic systems.
- Do not operate any functions of the carrier while cutting or crushing with your Genesis attachment, including boom and drive functions.
- Do not pull down structures with your Genesis attachment. Doing so may cause falling debris or material may break free and exceed the capacities of the carrier, causing a tipping hazard.

### **Lift the Load Safely**

- The hydraulic system has been preset and tested by your dealer. Do not alter hydraulic settings without consulting an authorized Genesis dealer or the Genesis Service Department. Doing so will void the warranty and may cause structural damage, accidents or tipping.
- Make sure the load is held securely in the jaws. Do not move a loaded attachment if load is loose or dangling. Make sure the load is pinched between the jaws – never cradle a load.
- For greater stability, knuckle the attachment to bring the load closer to the center of rotation (center of gravity) while lifting. Use extra caution during reaching to avoid tipping.

### **Place the Load Safely**

- Do not move the attachment, or anything held in the jaws, over people, equipment or buildings. Place the load gently. Do not throw or drop the contents.
- Operate the controls smoothly and gradually. Jerky controls are hazardous and may cause damage to the carrier.
- Avoid fire hazards. Keep the area clean. Remove all flammable materials from the area during any welding or heating process. Have a fire extinguisher nearby and know how to use it.
- Never substitute pins or bolts. Use factory supplied pins. Replace all bolts with the same size and grade. Failure to do so may cause serious injury or death.
- Use your Genesis attachment only as directed in this manual. Do not use the attachment to lift and move other objects. Doing so may cause instability and tipping.



## PROCESSOR MARKINGS

Decals are necessary for safe operation and maintenance. To reorder, contact your Genesis dealer or call 715-395-5252.

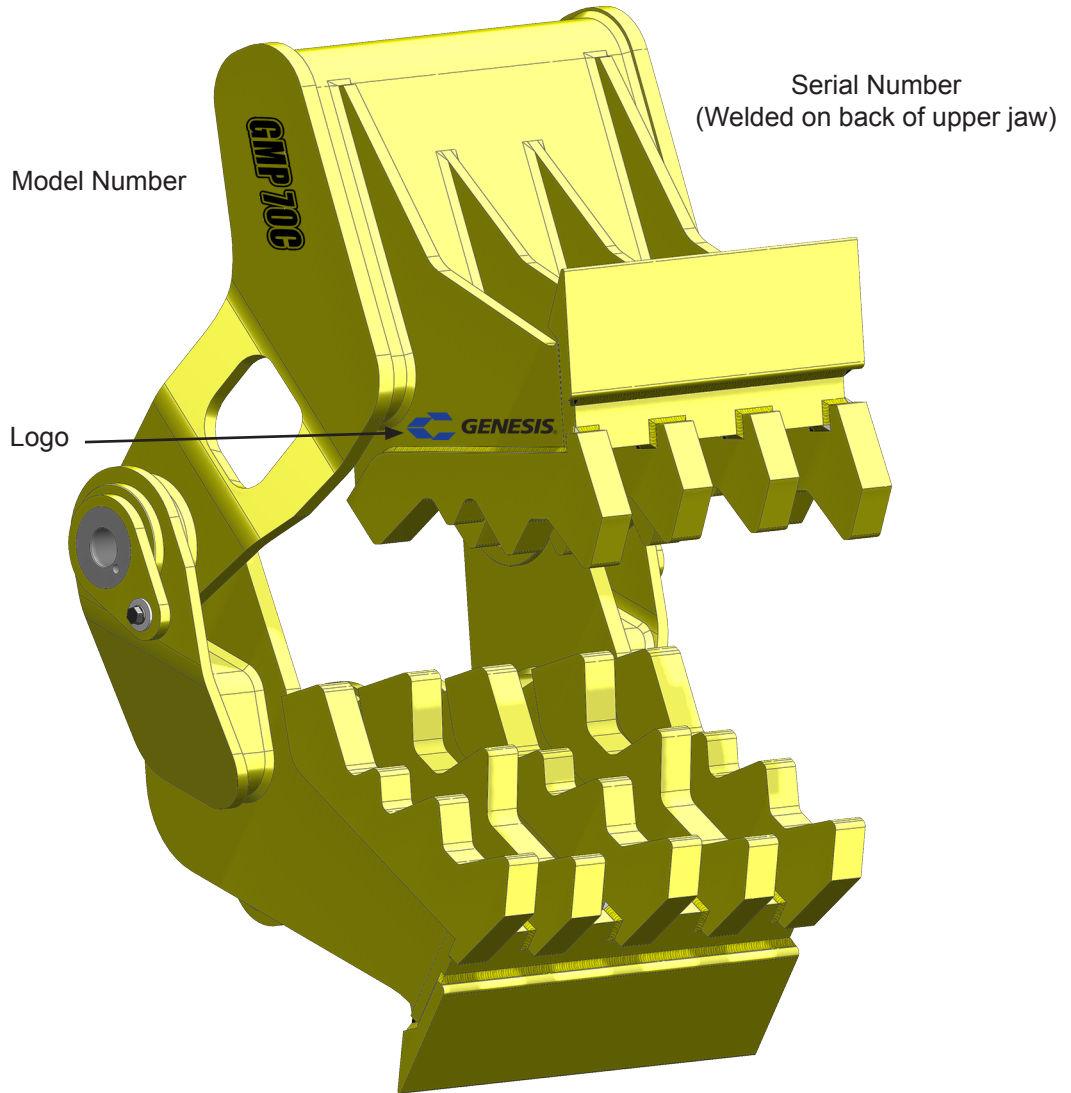



# NOTES

## PROCESSOR INSTALLATION

Preparation of the excavator prior to attachment delivery will make installation safer and easier. Contact Genesis or your Genesis dealer for assistance.

### Pad Installation

Curl the excavator stick under so the bottom of the stick is facing upward.

Use the mounting dimensions provided on your installation drawing to locate the correct placement of the stabilizer pad on the bottom of the stick. The stabilizer pad must be centered on and parallel to the stick.

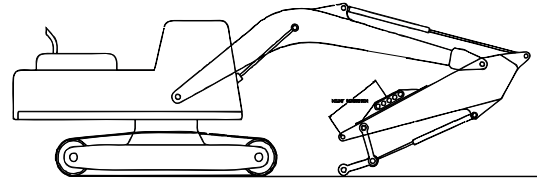

Weld the pad to the stick using E7018 low hydrogen electrode or equivalent. Weld per instructions provided on your installation drawing.

Install the stabilizer arm to the pad.



### **WARNING**

Removing any connecting pin may be hazardous. To remove a connecting pin, position the attachment on the ground and properly support.



### **WARNING**

Particles may fly when a pin is struck. Use a drift pin or mallet when striking pins. Keep all personnel at a safe distance.

# PROCESSOR INSTALLATION

## Processor Installation

Remove the bucket or other attachment following the manufacturer's procedure. Retract the bucket cylinder and associated linkage. The attachment is designed to sit flat on the ground and must be on a firm, level surface with the jaws closed.

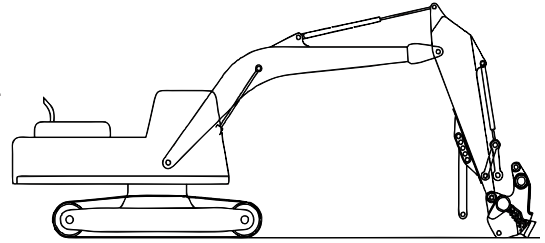

Position the excavator behind the attachment and carefully line up the stick connection of the excavator and attachment. Install pin.

Raise the tool slightly off the ground and extend the bucket cylinder.

Make sure all personnel stand clear. Lifting the tool will cause the jaw to close and stabilizer bar to swing.

Connect power link of excavator to upper jaw.

Align the stabilizer arm with the stationary jaw by moving the stick and operating the bucket cylinder. Pin the arm to the jaw.

Check all connections to ensure mounting pins are properly retained.

## Removal

To remove tool with stiff arm, set arm on heavy object. Remove pin from pad. Move tool to storage position with arm hanging.

Lower tool to ground. Close jaws to prevent tool movement after link pin is removed.

Remove pins.

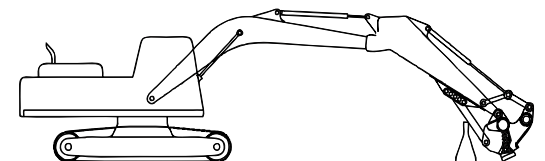
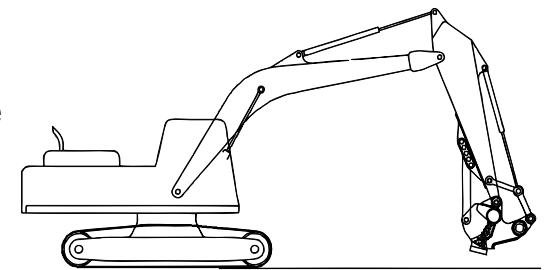
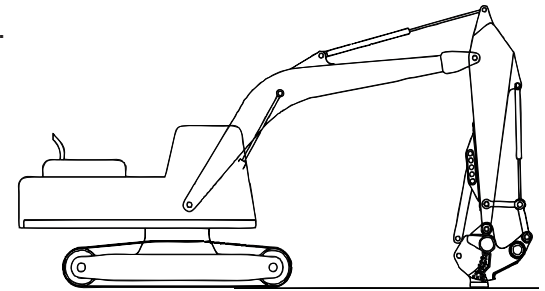

# WARNING

Lifting the attachment will cause the jaw to close and the stabilizer bar to swing. Keep all personnel at a safe distance.

## MAINTENANCE SAFETY

Only trained and authorized persons should perform maintenance on the attachment. To be qualified, you must understand the instructions in this manual, have training, and know the safety rules and regulations of the job site.

Do not alter the physical, mechanical or hydraulic operation of the attachment. Doing so may cause a dangerous situation for yourself and those around you and will void the warranty.

Do not attempt repairs you do not understand. If any questions arise regarding a safety or maintenance procedure, contact Genesis or your Genesis dealer.

Read this entire manual. All personnel must understand the maintenance and safety procedures.

Use factory authorized parts. The use of unauthorized parts may compromise safety, performance and durability of the attachment and may void the warranty.

Follow the daily checklist and maintenance schedules in this manual. Extreme conditions may dictate shorter maintenance intervals.

Do not exceed bolt torque specifications.

Do not weld on structural components without consulting Genesis. Doing so may cause structural failure and void the warranty.

Do not work on the attachment before ensuring it will not move. Completely lower the boom to the ground or a rest position and relieve hydraulic pressure.

Never operate poorly maintained equipment. When maintenance is required, repair or replace parts immediately.

Do not operate under unsafe conditions. If an unsafe condition arises during operation, immediately shut down the equipment and report the situation to the proper authority.

## MAINTENANCE SCHEDULE

Performing scheduled maintenance will promote safe, reliable operation of your attachment. Inspect and grease components every eight hours of operation, as indicated on the following checklist. Use maintenance procedures described in this manual. If you are not able to safely and competently perform these procedures, have a Genesis dealer perform them.

### NOTICE

Extreme operating conditions may require shortened maintenance intervals.

### Eight-Hour Checklist

#### Inspect:

- Bolts - check for loose bolts, replace if damaged
- Bracket pivot for wear and pin retainers
- Entire attachment for cracks (visual check)

#### Grease:

- Bracket pivot
- Main shaft/pivot (both sides)
- Stick tip and linkage joints per excavator OEM instructions
- Use a lithium-based premium EP #2 in normal conditions above 32° F (0° C). Use Grade 0 in temperatures below freezing.

Grease all locations until grease extrusion is visible.

#### Jaws and Teeth:

- Check teeth for wear
- Build-up and hard-surface as needed

# BOLT TORQUE SPECIFICATIONS

Genesis typically uses dry torque measurements.

Prior to using the chart below, clean all bolt holes, bolts and nuts to remove dirt, grease and oil. See the Visual Reference below to identify bolt type.

Never re-torque bolts that use Loctite. If a bolt becomes loose or damaged after the initial use when Loctite was applied and the bolt was torqued, the bolt must be replaced.

Never break tightened bolts loose with a torque wrench. Doing so may break the torque wrench or take it out of calibration.

Torque wrenches should be calibrated on an annual basis.

When using a torque multiplier with a torque wrench, incorrect settings will be multiplied by the ratio of the torque wrench.

Never use an air wrench on a torque multiplier.

Dry Torque Values					
Fastener Grade	Size x Pitch	Hex Head		Flat Head	
		Nm	Ft-lb	Nm	Ft-lb
CL 10.9	M8 x 1.25	36	27	29	22
	M10 x 1.50	72	53	58	42
	M12 x 1.75	125	92	100	74
	M14 x 1.50	210	154	168	123
	M14 x 2.00	200	148	160	118
	M16 x 2.00	313	230	250	184
	M20 x 1.50	640	472	512	378
	M20 x 2.50	610	450	488	360
	M24 x 3.00	1055	778	844	622
	M27 x 3.00	1543	1138	1234	910
8	M30 x 3.50	2095	1545	1676	1236
	1/2-13	145	107	116	86
	1/2-20	163	120	130	96
	5/8-11	286	211	229	169
	3/4-10	510	376	408	301
	7/8-9	822	606	658	485
	1.00-8	1220	900	976	720
	1.00-14	1345	992	1076	794
L9	1.50-6	4280	3160	3424	2528
9	1.25-7	2464	1817	1971	1454

Wet Torque Values					
Fastener Grade	Size x Pitch	Hex Head		Flat Head	
		Nm	Ft-lb	Nm	Ft-lb
CL 10.9	M20 x 2.50	458	338	366	270
	M24 x 3.00	790	583	632	466
	M27 x 3.00	1157	850	926	680
	M30 x 3.50	1572	1160	1258	928
8	3/4-10	383	282	306	226
	7/8-9	617	455	494	364
	1.00-8	916	675	733	540
	1.25-7	1847	1362	1478	1090
9	1.50-12	4067	3000	3254	2400

Apply grease or anti-seize on threads and under bolt heads

## Visual Reference

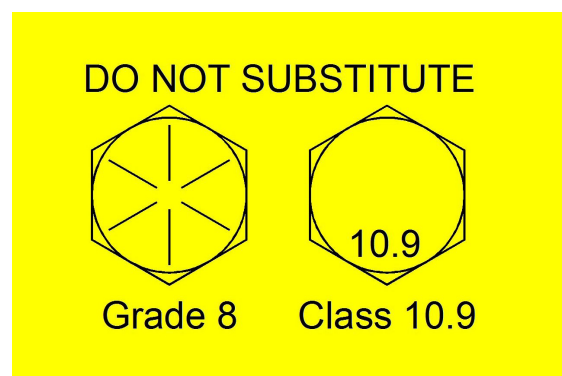

## BOLT TORQUE SPECIFICATIONS

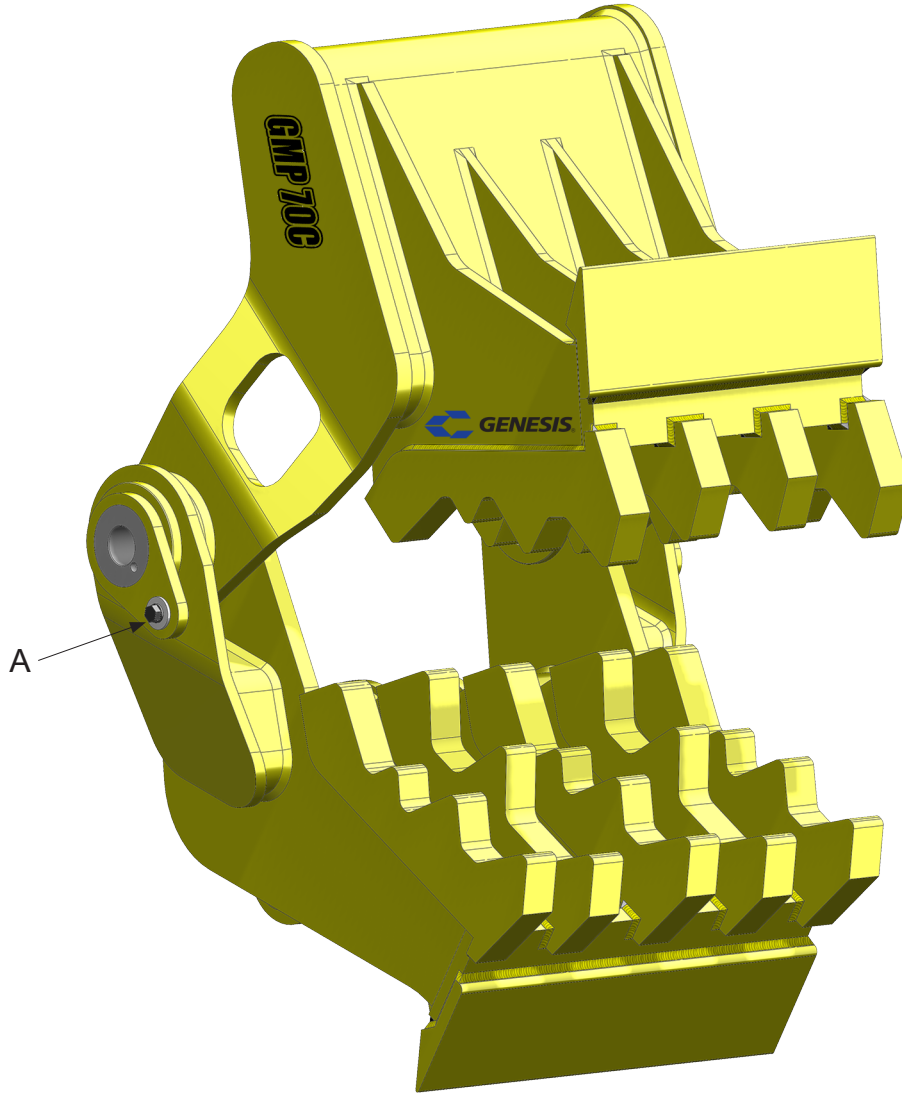

Item	Description	GMP 50/70/90
A	Spool retainer bolts	230 Ft-lbs (313 Nm)

## JAW MAINTENANCE

Tooth and jaw maintenance greatly affects performance. To maximize performance and optimize the life of replaceable parts, follow all instructions for checks, adjustments and maintenance described, at the intervals listed in this manual.

Before performing maintenance, read, fully understand and follow these safety rules.

Wear personal safety equipment including gloves, safety glasses, safety boots and proper clothing.

### **Pulverizing Teeth**

At the end of each shift, check the condition of pulverizing teeth.

Replace teeth when tips become severely rounded or flat. Dull teeth will process concrete less efficiently.

Teeth may be built up and hard-surfaced to extend their life.

The bypass of the outside rows of teeth is tight enough to cut rebar (front teeth). Maintaining square edges in these areas (both upper and lower) will allow continued cutting.

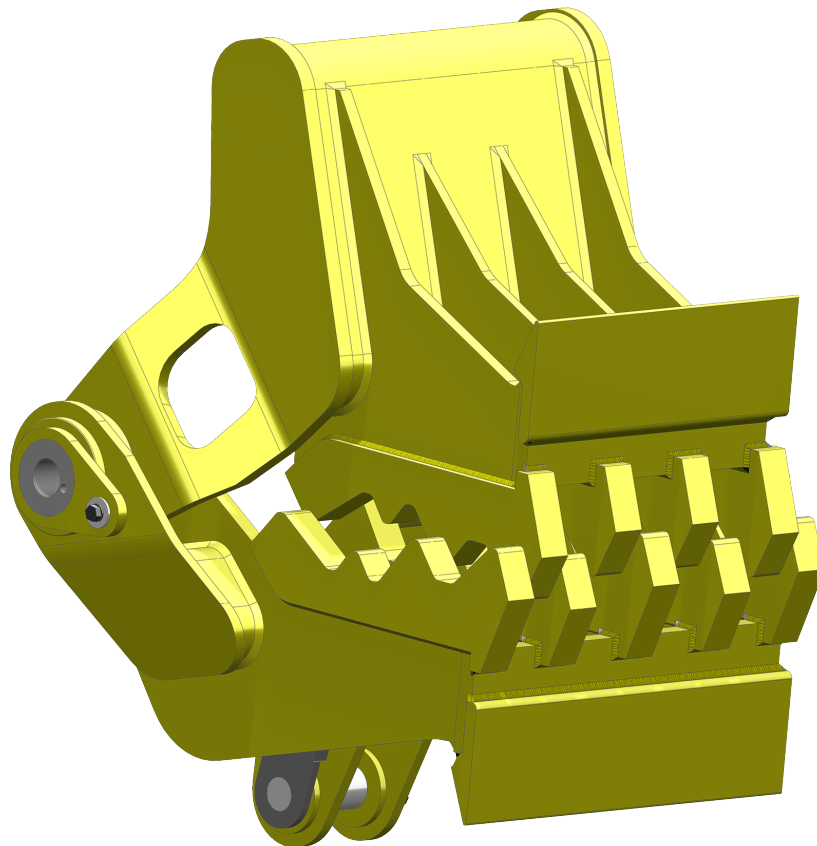



## GENERAL WELDING GUIDELINES

Hard-surfacing is the welding material added over the parent material to create a wear-resistant surface.

Welding should not be performed until the jaws are work-hardened. Work-hardening can take up to 80 hours.

### **Welding Ground Clamp**

**Disconnect all battery ground cables or shut off master battery switch, if equipped. Failure to do so may cause excavator electrical problems, including permanent damage to on-board computer systems.**

**Connect ground clamp as close as possible to the area being welded without allowing current to pass through the pivot group, cylinder pin, cylinder, swivel, motor, gearbox or slewing ring.**

**If you are welding on the lower jaw, connect weld clamp to the lower. If you are welding on the upper jaw, connect to the upper but not to the cylinder clevis. If needed, weld a piece of steel to the area for the grounding clamp and cut the piece off when welding is completed.**

### **Welding Rules**

Before you begin:

- Wearing an approved respirator, grind the area to clean it, removing all existing hard-surfacing.
- Preheat area to 350° F (177° C). Maintain this temperature throughout the procedure. Do not exceed 450° F (232° C) interpass temperature.

During welding:

- Always grind and weld with the grain of the material.
- Peen each weld pass to relieve stress and harden the welds.
- Do not undercut the ends of the welds.
- Do not start or stop welds directly above a bolt hole or in the apex of the jaw.

After welding maintenance is complete:

- Cover the area with a heat blanket and allow it to cool slowly, approximately eight hours.
- Do not put the attachment into operation until the welds have been allowed to cool.

## HARD-SURFACING

Do not apply hard-surfacing directly to the parent material as this could cause toe cracking, and the hard-surfacing will break away.

Procedure:

Follow the General Welding Guidelines and Rules.

Apply a single pass stringer bead pattern, using E7018 electrode. Peen each pass.

Do not apply a stringer directly on the edge. Start the first pass 1/4" from the edge.

Cap each stringer bead with one pass of GenWire or GenRod to hard-surface. Do not apply more than two layers of hard-surfacing. Peen each pass.

Grind the ends of all stringer welds with the grain to taper 1" to 1-1/2" (25 - 38 mm) to the parent material.

See the following page for hard-surfacing illustrations and instructions specific to each area of the jaws.

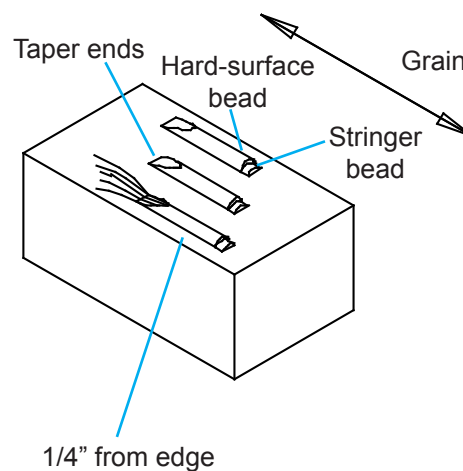

## HARD-SURFACING PATTERNS

Where parallel lines are shown, apply single passes approximately 1" apart. Where crosshatch is shown, apply stringer beads at 45° angles to form 1" squares.

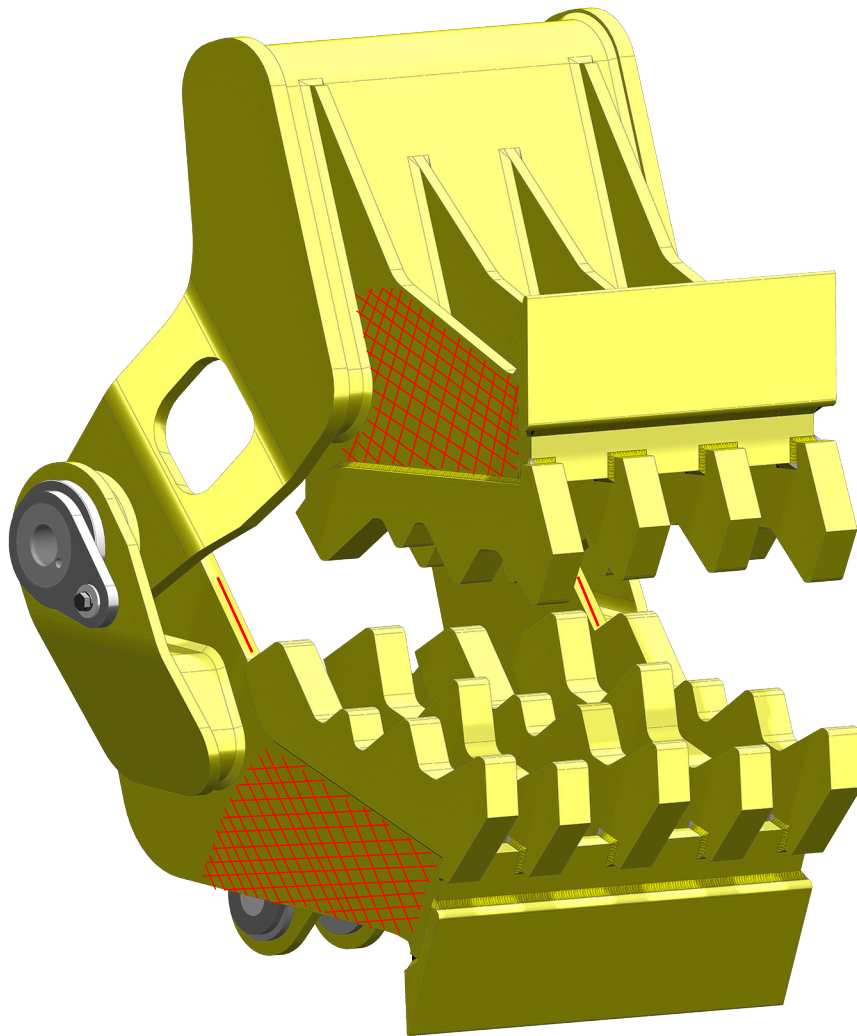

## TROUBLE-SHOOTING GUIDE

Symptom	Possible Cause	Possible Solution
Lacks power	Cutting force depends on excavator linkage - different geometry produces different results	Move the stiff arm forward one hole (closer to the tool), decreasing jaw opening but yielding more power  *See warning below
Poor cutting/crushing	Material size is beyond attachment appetite range	Consult the factory
	Worn pulverizing teeth	Replace component or build-up and hard-surface



### CAUTION

\*Moving stiff arm back one hole (farther from the tool) from factory recommended position may result in linkage toggle and damage to bucket cylinder.

# WARRANTY

## **Claim Procedure**

Notify the Genesis Service Department of the potential warranty claim prior to making the repair. Digital pictures are very helpful for diagnosing problems and recommending repairs.

Contact the Genesis Service Department before making alterations, changes or repairs to any component that is going to be considered for warranty. Not doing so will void all Genesis warranty consideration.

The Genesis Service Department will issue an authorization number to track the repair costs, outgoing parts, and/or defective parts returning to the factory.

Replacement parts must be ordered using a purchase order number. Shipping is standard ground. Overnight shipping is available by request, and Genesis will not cover the shipping charge.

When the repair is complete, submit an invoice to the Genesis Service Department within 30 days. Include itemized internal labor reporting, parts lists and invoices for outside contractors. Reference the authorization number on all invoices.

When returning parts for warranty consideration, include a copy of any related Genesis paperwork along with any other necessary documentation to ensure proper processing and credit. The Genesis Service Department will provide the necessary forms.

Your account will be credited when the warranty claim is accepted.

## **Blade Warranty**

Standard warranty on blades will only be considered on the first edge, and wear on the edge must be 1/8" radius or less. Genesis does not warranty cutting blades that are cracked or broken from top to bottom (perpendicular to the long edge of the blade). Genesis also does not cover fasteners, the labor to replace wear components or collateral damage, such as blade seats, from broken blades, the piercing blade tang or adjustment plates.

**Please direct any questions to the Genesis Service Department: 715-395-5252**

# PARTS ORDER POLICY AND PROCEDURE

## **Parts Orders Should Include**

- Purchase order number
- Model and serial number of attachment
- Part number and quantity needed
- Shipping and billing address
- Method of shipment or required delivery date

## **Placing Orders**

Orders may be placed by phone, e-mail or fax. To fax an order, use the form on the following page. Contact information is located at the front of this manual.

## **Part Numbers**

Part numbers are listed in a separate Parts Manual or, if included, the Parts section of this manual. Contact the Genesis Parts Department with questions regarding part numbers, availability and pricing.

## **Shipping**

All orders will be shipped best way surface unless an alternate shipping method is requested. Shipping charges are not included in the purchase price of parts.

## **Invoices**

All invoices are due upon receipt. Any accounts with invoices open beyond 60 days are subject to review and may be placed on C.O.D. status without further notice.

## **Returns**

Unused Genesis parts may be returned with proper documentation. Return shipping is the responsibility of the purchaser. Credit will be issued upon return, less a 20% restocking fee. Documentation is required for credit of returned parts. Contact the Genesis Parts Department at 715-395-5252 for a RGA (Return Goods Authorization) number and form.

## **Return Goods Authorization**

All parts returned to Genesis for warranty consideration must be returned with a completed RGA (Return Goods Authorization) provided by the Genesis Parts Department. The form needs to be completed in its entirety, including any additional information requested by the Parts or Service Department. Return freight is the responsibility of the shipper and will be credited upon claim approval. A determination to accept or deny the claim will be made based on the information available to Genesis. Warranty on purchased parts other than wear components is 6 months. There is no warranty period on wear parts or components.



## PARTS

The following page contains a GMP illustration and parts list. The illustration identifies major components and may not be identical in fine detail to a particular attachment.

The parts list included here is intended to aid in operation and maintenance. If further information is required, contact the Genesis Parts Department for a breakdown and parts list specific to your attachment model and serial number.

Part numbers listed are those currently used. These may differ from the part numbers of the components originally installed in your attachment. To ensure use of the correct internal components, always indicate your attachment's serial number when ordering parts.



# PARTS

## Wear Parts

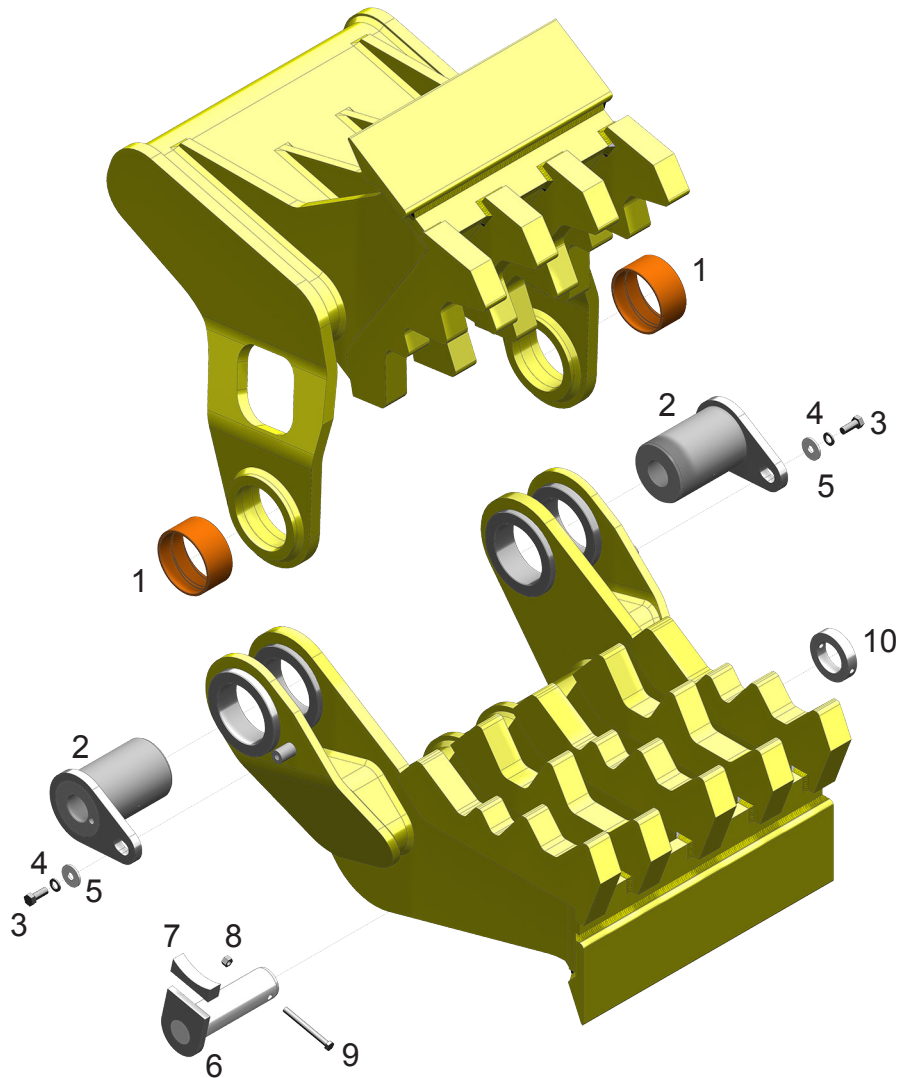

Item	Description	Qty	Part Number	
			GMP 50C GMP 70C	GMP 90C
1	Mach Bearing	2	4502596	4502702
2	Wldt Spool	2	4502601	4502708
3	Hex Head Capscrew M20 x 2.5 x 50 CL10.9 DIN	2	F0120050	F0120050
4	Flat Washer M20 DIN 6916 (37 x 4) Class 10	2	F1202037	NA
5	Mach Washer (M20 x 2.00 x .25)	2	2101497	2101497
6	Wldt Pin Stiff Arm	1	4502600	4502709
7	Plt Stiff Arm Keeper	1	4502599	4502599
8	Nylock Hex Nut M16 x 2.0 CL10.9 Black	1	F1016200	F1016200
9	Hex Head Capscrew M16 x 2.0 x 160 CL10.9 DIN	1	F0116160	F0116160
10	Mach Collar T1100281	1	4500269	4500269



**GENESIS®**

The Promise of Performance.

## CONTACT INFORMATION

### **World Headquarters Genesis Attachments**

1000 Genesis Drive  
Superior, WI 54880 USA

Toll Free: 888-SHEAR-IT  
(888-743-2748)

Phone: 715.395.5252  
Fax: 715.395.5255

E-mail:  
info@genesisattachments.com

### **Europe/Africa/Middle East Genesis GmbH**

Teramostrasse 23  
87700 Memmingen, Germany

Phone: +49 83 31 9 25 98 0  
Fax: +49 83 31 9 25 98 80  
genesis-europe.com

E-mail:  
info@genesis-europe.com

### **Asia Pacific Representative Office**

24 Upper Serangoon View #12-28  
Singapore 534205

Phone: +65 9673 9730

E-mail:  
tchoo@genesisattachments.com

### **Central & South America, The Caribbean**

Cra 13A #89-38 / Ofi 613  
Bogota, Colombia

Phone: +57 1 610 8160 / 795 8747

E-mail:  
contact@themsagroup.com

### **Brazil**

Avenida Araça, 1677  
Campinas - São Paulo

Phone: +55 19 9 9989-8803

E-mail:  
gel@themsagroup.com

View and download all manuals at [genesisattachments.com/manuals.asp](http://genesisattachments.com/manuals.asp)

Patents: [genesisattachments.com/patents](http://genesisattachments.com/patents)