

**GENESIS**<sup>®</sup>

The Promise of Performance.

# Scrap Grapple (GSG)

All Models Prior to July 2014

**PARTS MANUAL**



## CONTACT INFORMATION

### Genesis Attachments

1000 Genesis Drive  
Superior, WI 54880 USA

Toll Free: 888-SHEAR-IT  
(888-743-2748)

Phone: 715.395.5252

E-mail:  
info@genesisattachments.com

### Europe/Africa/Middle East Genesis GmbH

Teramostrasse 23  
87700 Memmingen, Germany

Phone: +49 83 31 9 25 98 0  
Fax: +49 83 31 9 25 98 80  
genesis-europe.com

E-mail:  
info@genesis-europe.com

### Asia Pacific Representative Office

24 Upper Serangoon View #12-28  
Singapore 534205

Phone: +65 9673 9730

E-mail:  
tchoo@genesisattachments.com

### Central America & Colombia

Cra 13A #89-38 / Ofi 613  
Bogota, Colombia

Phone: +57 1 610 8160 / 795 8747

E-mail:  
contact@themsagroup.com

View and download all manuals: [genesisattachments.com/manuals](http://genesisattachments.com/manuals)  
Patents: [genesisattachments.com/products/patents](http://genesisattachments.com/products/patents)

# TABLE OF CONTENTS

<b>CONTACT INFORMATION</b>	<b>2</b>
<b>GSG 75/100 ASSEMBLY GRAPPLE TOWER - 2200233</b>	<b>4</b>
<b>GSG 125/150/200/250 ASSEMBLY GRAPPLE TOWER - 2200289</b>	<b>6</b>
<b>GSG 75/100/125/150/200/250 ASSEMBLY TINE KITS</b>	<b>8</b>
<b>GSG 75/100/125/150/200/250 ASSEMBLY UPPER HEAD - 2200290</b>	<b>10</b>
<b>GSG 75/100 ASSEMBLY CYLINDER B4.5 R3.0 S8.0 - 6350037</b>	<b>12</b>
<b>GSG 125/150/200/250 ASSEMBLY CYLINDER B4.5 R3.0 S10.0 - 6350036</b>	<b>14</b>
<b>GSG 75/100/125/150/200/250 ASSEMBLY SWIVEL - 6350039</b>	<b>16</b>
<b>GSG 75/100 ASSEMBLY HYDRAULIC - 2200308</b>	<b>18</b>
<b>GSG 125/150/200/250 ASSEMBLY HYDRAULIC - 2200307</b>	<b>20</b>
<b>GSG 75/100/125/150/200/250 ASSEMBLY YOKE (FORKED STICK)</b>	<b>22</b>
<b>GSG 75/100/125/150/200/250 ASSEMBLY YOKE</b>	<b>24</b>
<b>BOLT TORQUE SPECIFICATIONS</b>	<b>26</b>
<b>THREAD TREATMENT DIAGRAM</b>	<b>27</b>
Grapples	27
<b>PROCEDURES</b>	<b>28</b>
Cleaning	28
Threadlocker	28
Anti-Seize	29
No Thread Treatment	29
<b>BOLT TORQUE SPECIFICATIONS</b>	<b>30</b>
Dry Torque Values	30
Wet Torque Values	30
<b>O-RING BOSS &amp; FLAT FACE O-RING TORQUE SPECIFICATIONS</b>	<b>31</b>
<b>BOLT DRIVE SPECIFICATIONS</b>	<b>32</b>
<b>WARRANTY</b>	<b>33</b>
Claim Procedure	33
Blade Warranty	33
<b>PARTS ORDER POLICY AND PROCEDURE</b>	<b>34</b>
Parts Orders Should Include	34
Placing Orders	34
Part Numbers	34
Shipping	34
Invoices	34
Returns	34
Return Goods Authorization	34
<b>PARTS ORDER FORM</b>	<b>35</b>
<b>INDEX</b>	<b>36</b>
<b>CONTACT INFORMATION</b>	<b>38</b>

# GSG 75/100 ASSEMBLY GRAPPLE TOWER - 2200233

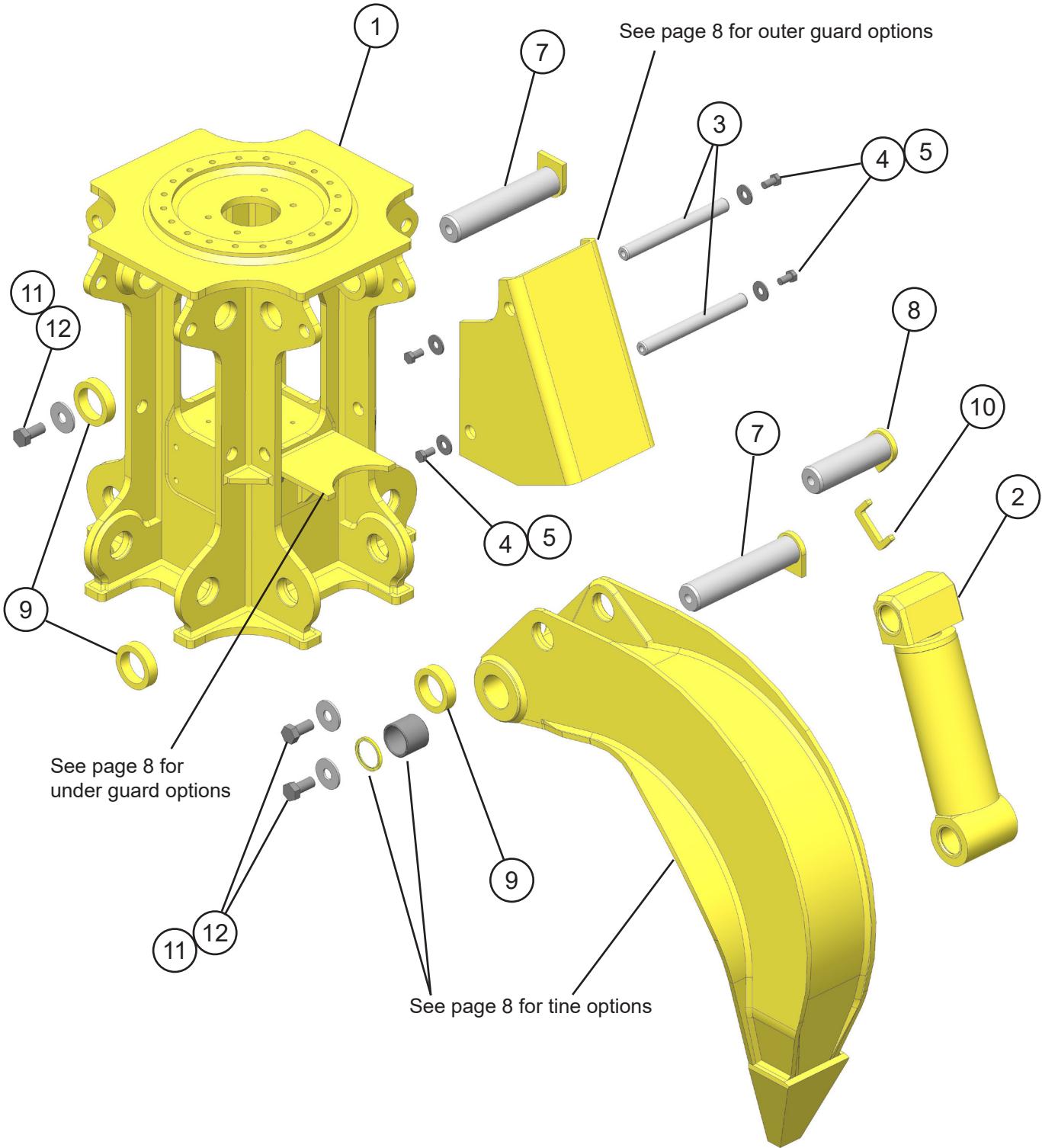

## GSG 75/100 ASSEMBLY GRAPPLE TOWER - 2200233

ITEM	QTY	PART NUMBER	DESCRIPTION
1	1	2200257	Wtmg Frame GSG 75/100
2	4	6350037	Assembly Cylinder B4.5 R3.0 S8.0
3	8	2200221	Mach Guard Mount Bar 1.25 Rnd
4	32	F0116030	Hex Head Capscrew M16 x 2.0
5	16	F1310058	Flat Washer Wide .58 x 1.75 OD USS
6	16	F1201630	Flat Washer M16
7	8	2200401	Wldt Pin 2.50 x 11.75
8	4	2200404	Wldt Pin 2.50 x 8.125
9	12	2200231	Plt Boss 4.00 x 2.88 x 1.00
10	4	2200234	Plt Pin Keeper
11	12	2200232	Mach Washer 1.00 x 2.75 x .19
12	12	F0124050	Hex Head Capscrew M24 x 3 x 50
13	1	2200308	Assy Hyd GSG 75/100

# GSG 125/150/200/250 ASSEMBLY GRAPPLE TOWER - 2200289

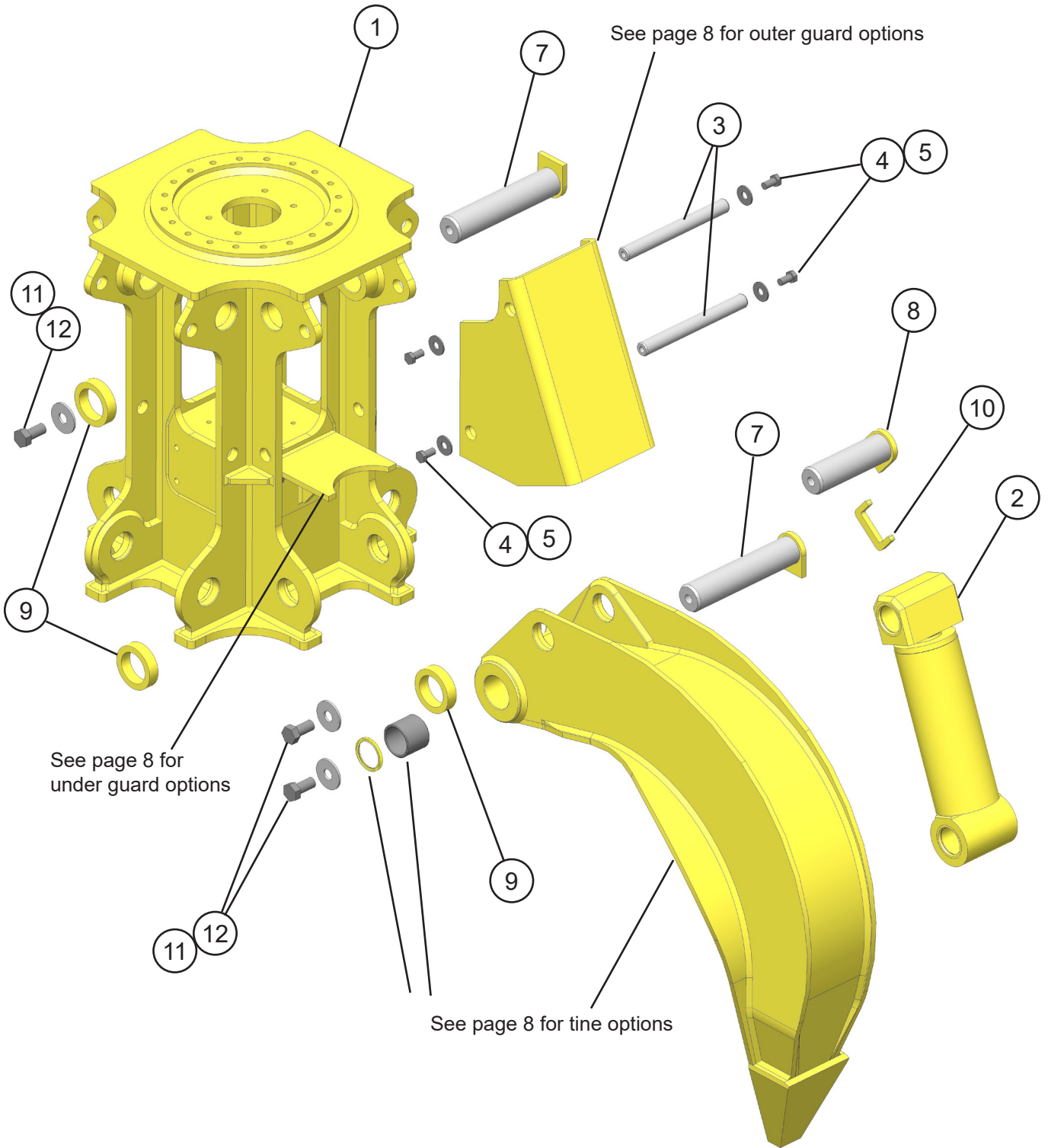

## GSG 125/150/200/250 ASSEMBLY GRAPPLE TOWER - 2200289

ITEM	QTY	PART NUMBER	DESCRIPTION
1	1	2200235	Wtmg Frame GSG 125/150/200
2	4	6350036	Assembly Cylinder B4.5 R3.0 S8.0 GSG 75/100
3	8	2200221	Mach Guard Mount Bar 1.25 Rnd
4	32	F0116030	Hex Head Capscrew M16 x 2.0
5	16	F1310058	Flat Washer Wide .58 x 1.75 O.D. USS
6	16	F1201630	Flat Washer M16
7	8	2200401	Wldt Pin 2.50 x 11.75
8	4	2200404	Wldt Pin 2.50 x 8.125
9	12	2200231	Plt Boss 4.00 x 2.88 x 1.00
10	4	2200234	Plt Pin Keeper
11	12	2200232	Mach Washer 1.00 x 2.75 x .19
12	12	F0124050	Hex Head Capscrew M24 x 3 x 50
13	1	2200307	Assy Hyd GSG 125/150/200

# GSG 75/100/125/150/200/250 ASSEMBLY TINE KITS

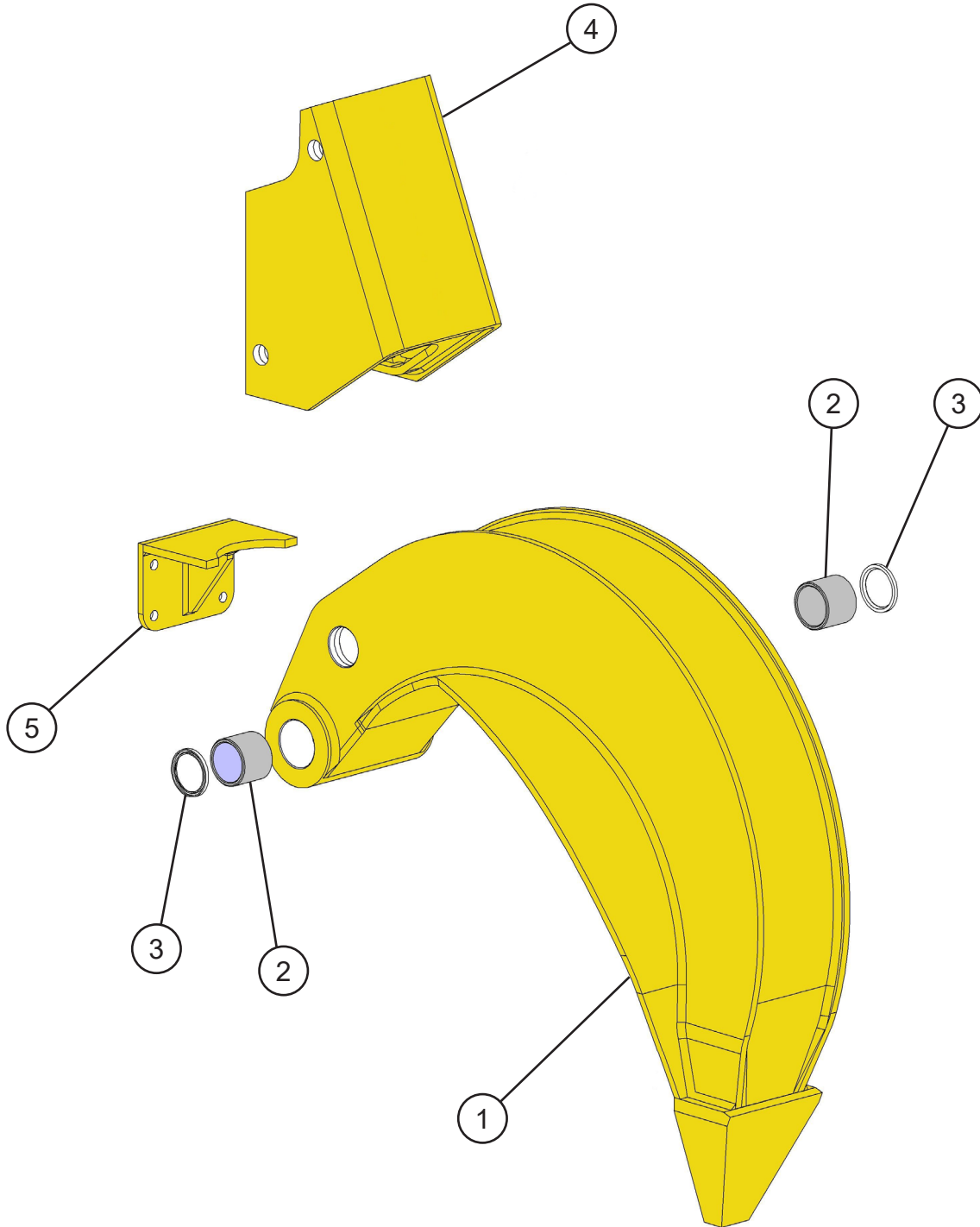



# GSG 75/100/125/150/200/250 ASSEMBLY TINE KITS

		GSG 75				GSG 100			
		Flat		Point		Flat		Point	
		Narrow 2200370	Medium 2200374	Narrow 2200309	Medium 2200313	Narrow 2200371	Medium 2200375	Narrow 2200310	Medium 2200314
<b>Item</b>	<b>Assembly Tine Kit</b>								
1	Wtmg Tine	2200330	2200339	2200285	2200265	2200341	2200347	2200287	2200270
2	Mach Bearing	2200406							
3	Seal	6300899							
4	Outer Guard	2200317		2200275		2200317		2200275	
5	Under Guard	2200325		2200279		2200325		2200279	

		GSG 125				GSG 150			
		Flat		Point		Flat		Point	
		Narrow 2200372	Medium 2200376	Narrow 2200311	Medium 2200315	Narrow 2200373	Medium 2200377	Narrow 2200312	Medium 2200316
<b>Item</b>	<b>Assembly Tine Kit</b>								
1	Wtmg Tine	2200349	2200357	2200281	2200190	2200359	2200364	2200283	2200260
2	Mach Bearing	2200406							
3	Seal	6300899							
4	Outer Guard	2200321		2200246		2200321		2200246	
5	Under Guard	2200327		2200222		2200327		2200222	

		GSG 200				GSG 250			
		Flat		Point		Flat		Point	
		Narrow 2200395	Medium 2200394	Narrow 2200393	Medium 2200383	Narrow 2200432	Medium 2200431	Narrow 2200430	Medium 2200429
<b>Item</b>	<b>Assembly Tine Kit</b>								
1	Wtmg Tine	2200391	2200396	2200284	2200278	2200428	2200427	2200426	2200425
2	Mach Bearing	2200406							
3	Seal	6300899							
4	Outer Guard	2200321		2200246		2200321		2200246	
5	Under Guard	2200327		2200222		2200327		2200222	

# GSG 75/100/125/150/200/250 ASSEMBLY UPPER HEAD - 2200290

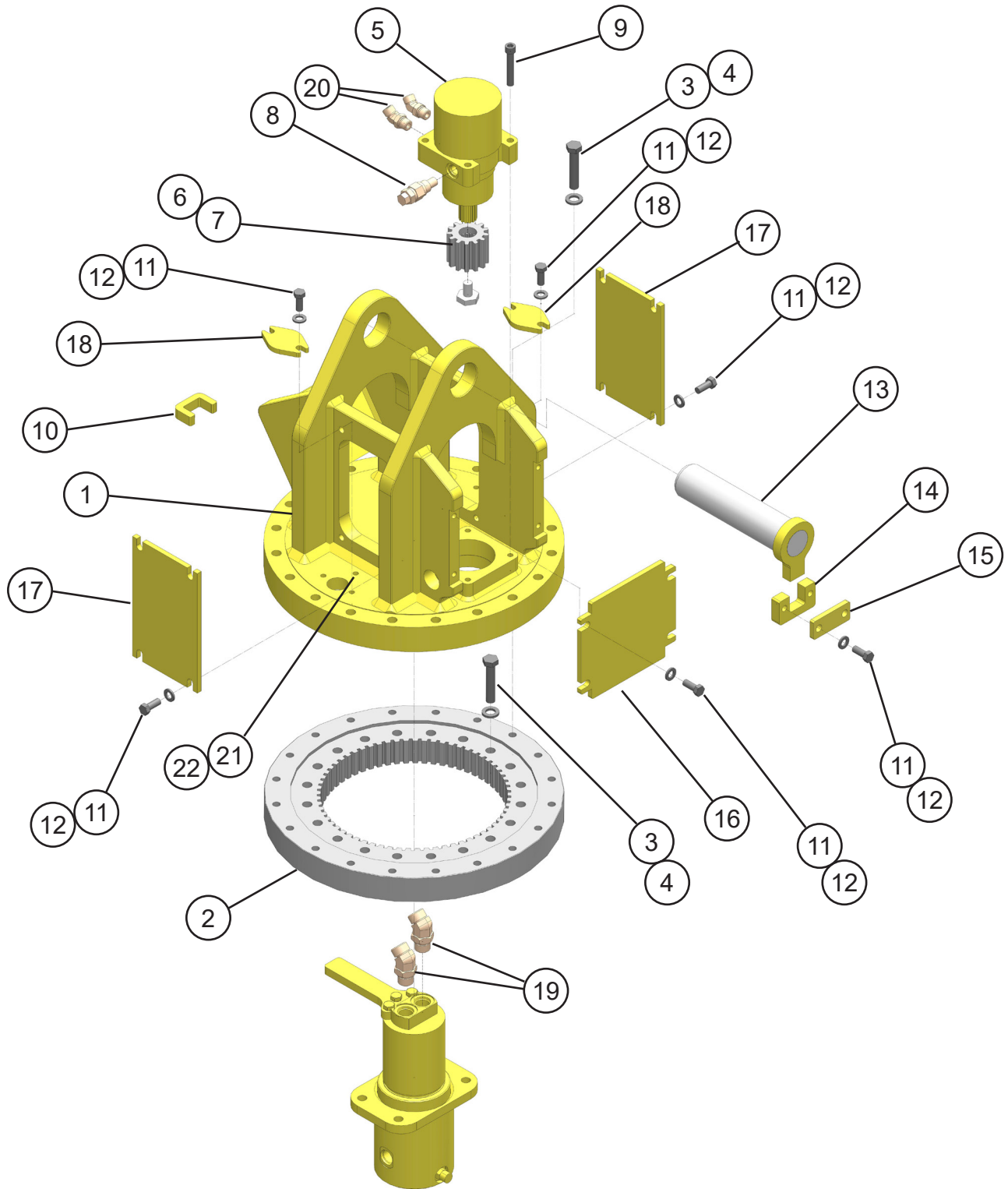

**GSG 75/100/125/150/200/250 ASSEMBLY UPPER HEAD - 2200290**

<b>ITEM</b>	<b>QTY</b>	<b>PART NUMBER</b>	<b>DESCRIPTION</b>
1	1	2200291	Wtmg, Head GSG 75/100/125/150 - Genesis
2	1	6300900	Bearing, Slewing
3	40	F0116080	Hex Head Capscrew M16 x 2 x 80
4	40	F1201630	Flat Washer M16
5	1	6340010	Motor, Grapple Rotate
6	1	6300901	Pinion GSG 13 Tooth
7	1	F0375201	Hex Head Capscrew $\frac{5}{8}$ x 11 x 1
8	1	6300902	Cartridge, Crossport Relief
9	4	F0612070	Socket Head Capscrew M12 x 1.75
10	1	2200293	Plt, Torque Arm Stop - GSG Head
11	18	F0112030	Hex Head Capscrew M12 x 1.75
12	18	F1201224	Flat Washer M12
13	1	2200301	Wldt, Pin - Std
14	1	2200304	Mach, Pin Keeper - GSG Head
15	1	2200306	Plt, Bar Strap - GSG Head
16	1	2200298	Plt, End Cover - GSG 75/100/125/150 Head
17	2	2200300	Plt, Side Cover - GSG Head
18	2	2200299	Plt, Bolt Cover - GSG Head
19	2	6310034	Adaptor $\frac{3}{4}$ " - 45
20	2	6300303	Adaptor $\frac{1}{2}$ " - 90
21	1	6300094	Compression Connector $\frac{1}{4}$ Tube - 18NPT
22	1	6200002	Grease Fitting $\frac{1}{8}$ - 27 NPT

# GSG 75/100 ASSEMBLY CYLINDER B4.5 R3.0 S8.0 - 6350037

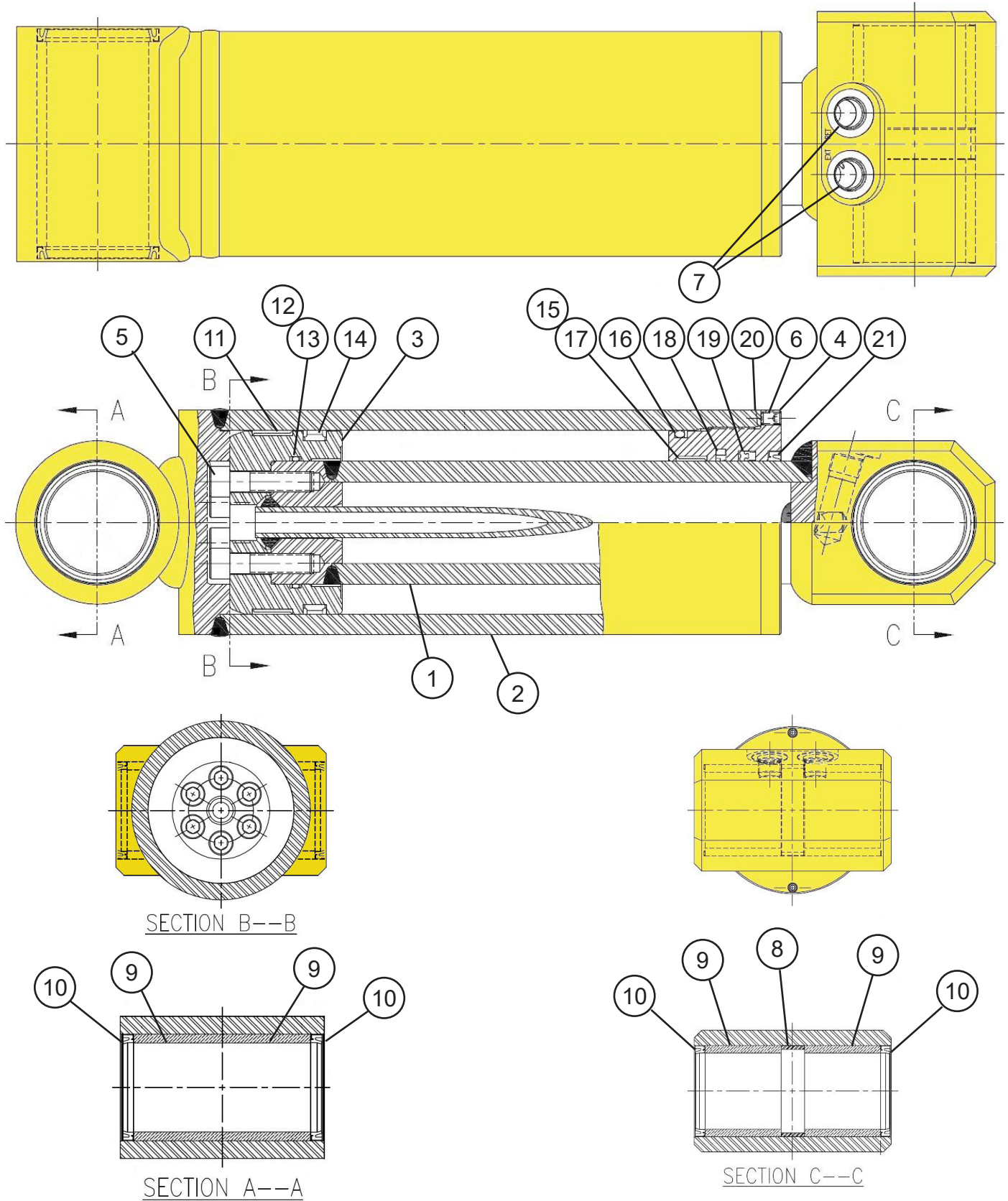

**GSG 75/100 ASSEMBLY CYLINDER B4.5 R3.0 S8.0 - 6350037**

<b>ITEM</b>	<b>QTY</b>	<b>PART NUMBER</b>	<b>DESCRIPTION</b>
1	1	6350048	Piston Tube Assembly
2	1	6350049	Butt & Tube Assembly
3	1	6350050	Piston
4	1	6350051	Gland
5	6	6300924	Socket Head Capscrew (1/2 - 20)
6	2	6300925	Set Screw (5/16 - 18)
7	2	6300926	Port Plug (3/4 - 16)
8	1	6300927	Steel Spacer
9	4	6300928	Fiber Bushing
10	4	6300929	Pin Wiper
11	1	6300930*	Bearing Ring, Piston
12	1	6300931*	O-Ring
13	2	6300932*	Vented Back Up Washer
14	1	6300933*	Capped T-Seal
15	1	6300934*	O-Ring
16	1	6300935*	Back Up Washer
17	1	6300936*	Bearing Ring, Gland
18	1	6300937*	Buffer Seal
19	1	6300938*	Deep Z-Seal
20	1	6300940*	O-Ring
21	1	6300941*	Canned Wiper
*	1	6300942	Packing Kit



**GSG 125/150/200/250 ASSEMBLY CYLINDER B4.5 R3.0 S10.0 - 6350036**

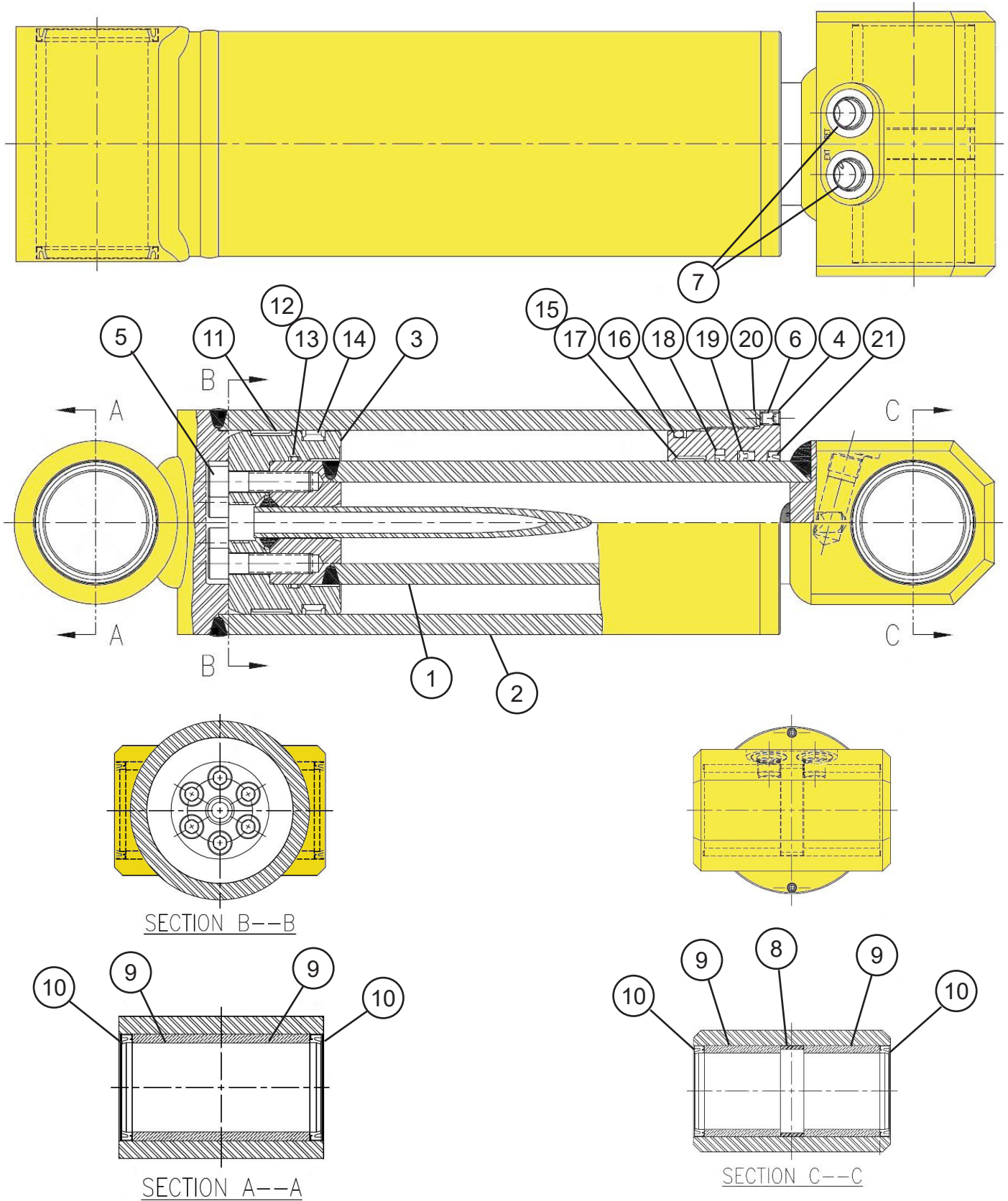

**GSG 125/150/200/250 ASSEMBLY CYLINDER B4.5 R3.0 S10.0 - 6350036**

ITEM	QTY	PART NUMBER	DESCRIPTION
1	1	6350052	Piston Tube Assembly
2	1	6350053	Butt & Tube Assembly
3	1	6350050	Piston
4	1	6350051	Gland
5	6	6300924	Socket Head Capscrew (1/2 - 20)
6	2	6300925	Set Screw (5/16 - 18)
7	2	6300926	Port Plug (3/4 - 16)
8	1	6300927	Steel Spacer
9	4	6300928	Fiber Bushing
10	4	6300929	Pin Wiper
11	1	6300930*	Bearing Ring, Piston
12	1	6300931*	O-Ring
13	2	6300932*	Vented Back Up Washer
14	1	6300933*	Capped T-Seal
15	1	6300934*	O-Ring
16	1	6300935*	Back Up Washer
17	1	6300936*	Bearing Ring, Gland
18	1	6300937*	Buffer Seal
19	1	6300938*	Deep Z-Seal
20	1	6300940*	O-Ring
21	1	6300941*	Canned Wiper
*	1	6300976	Packing Kit

# GSG 75/100/125/150/200/250 ASSEMBLY SWIVEL - 6350039

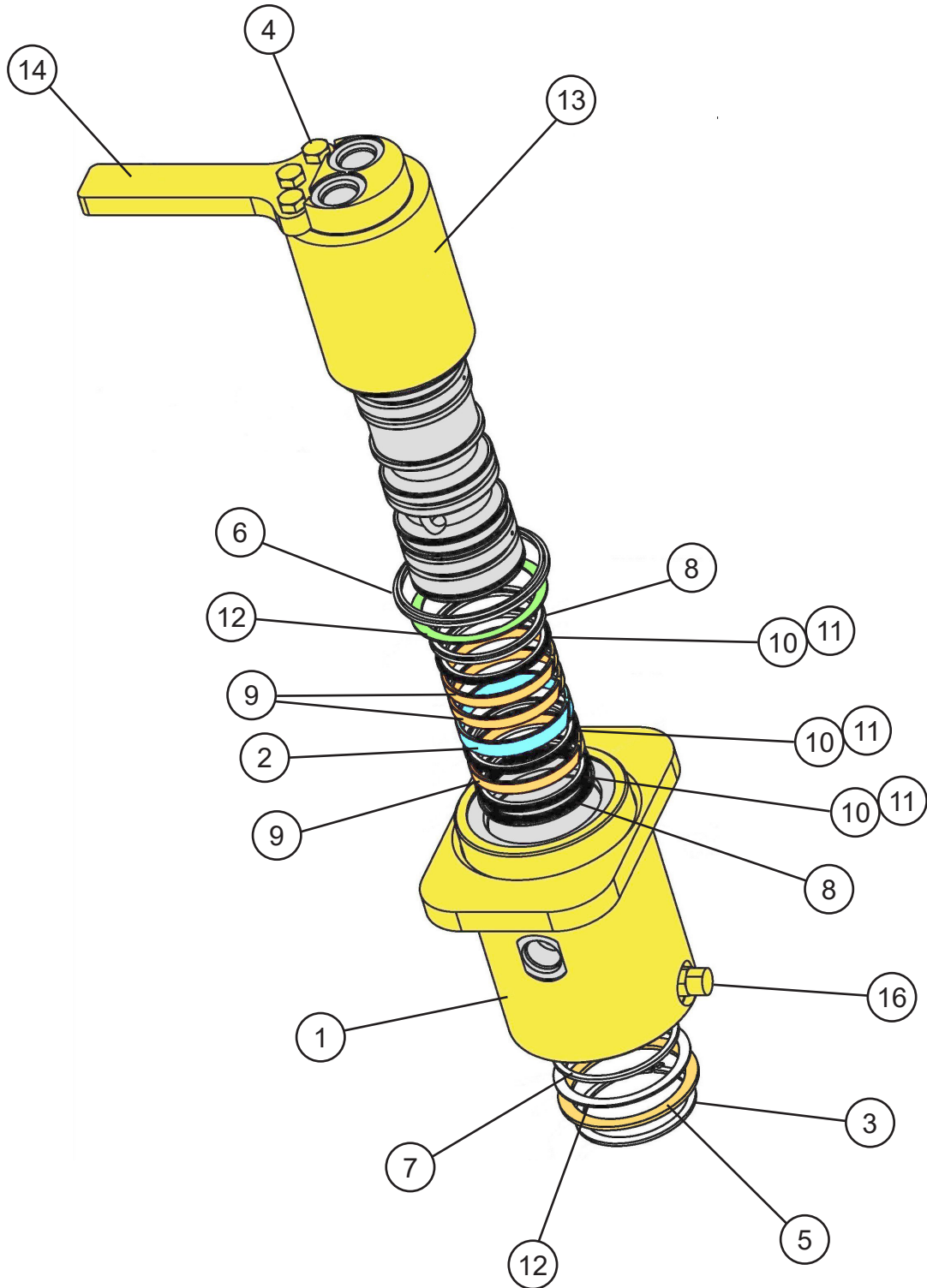



**GSG 75/100/125/150/200/250 ASSEMBLY SWIVEL - 6350039**

<b>ITEM</b>	<b>QTY</b>	<b>PART NUMBER</b>	<b>DESCRIPTION</b>
1	1	6300949	Housing ASM 2 Circuit
2	1	6300950	Ring, Wear*
3	1	6300951	Ring, Retaining
4	3	6300952	HHCS M12 x 1.75 x 45mm Gr 10.9 ZC
5	1	6300953	Washer, Flat 3.28 STL .120
6	1	6300954	Wiper, Sgl Lip for 4.00 Rod*
7	1	6300955	Wiper, Sgl Lip for 3.25 Rod*
8	2	6300956	Seal, U-Cup*
9	3	6300957	Ring, Wear*
10	3	6300958	Seal, Piston*
11	3	6300959	Energizer, Sq*
12	2	6300960	Washer, Thrust*
13	1	6300961	Spool - 2 Circuit
14	1	6300962	Arm, Torque .62 x 7.12 STL
15	1	6300963	Tape, Installation - Seal 24" Long*
16	1	6300966	Pressure Relief Valve - 500 PSI (Port W)
*		6300965	Seal Kit

# GSG 75/100 ASSEMBLY HYDRAULIC - 2200308

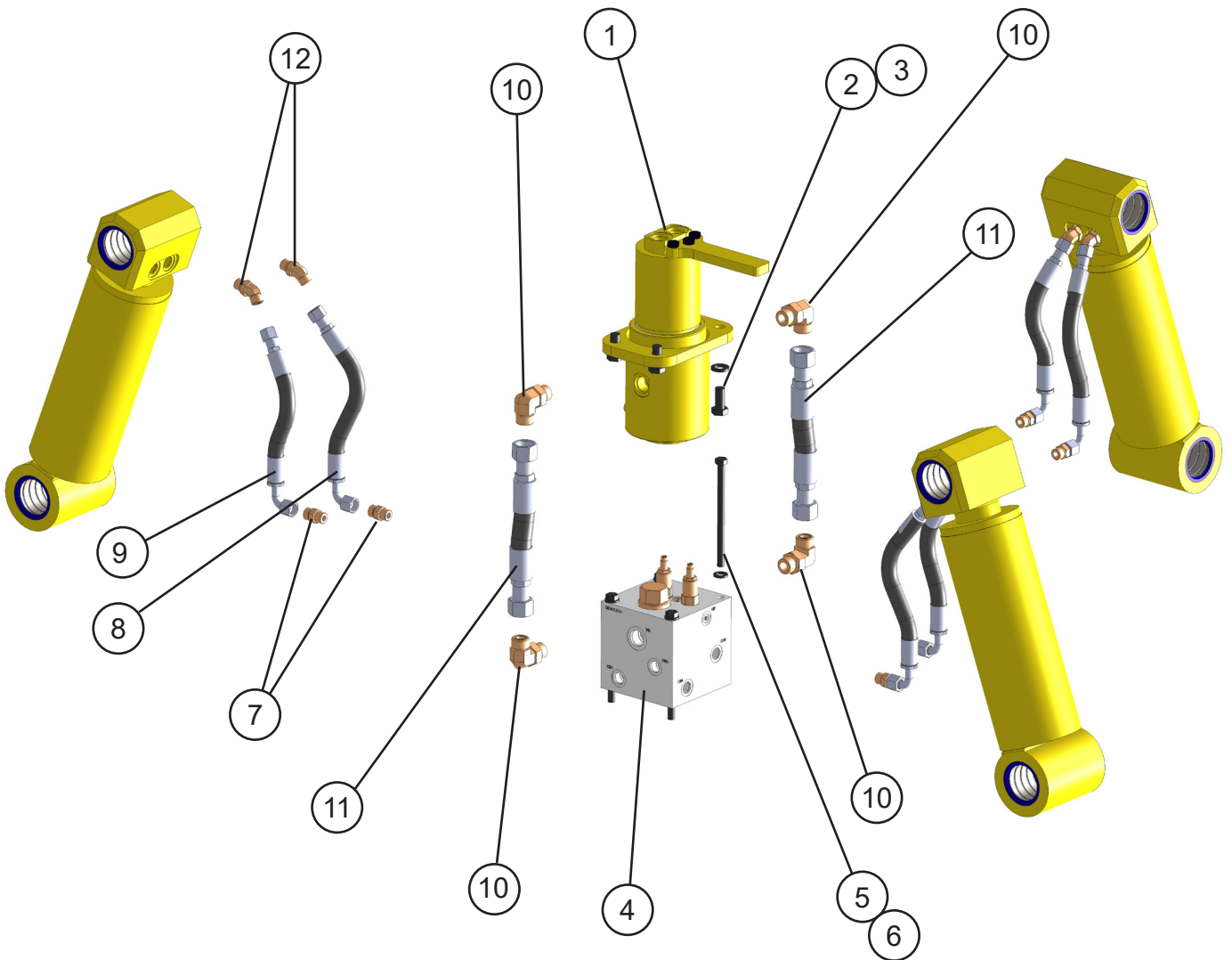

## GSG 75/100 ASSEMBLY HYDRAULIC - 2200308

ITEM	QTY	PART NUMBER	DESCRIPTION
1	1	6350039	Assembly Swivel Manifold
2	4	F0116035	Hex Head Capscrew M16 x 2.0
3	4	F1201630	Flat Washer M16
4	1	6380070	Assembly Valve Manifold
5	4	F0112180	Hex Head Capscrew M12 x 1.75
6	4	F1201224	Flat Washer M12
7	4	5300416	Assembly Hose
8	4	5300415	Assembly Hose
9	8	6300017	Adaptor 1/2" Straight
10	8	6300302	Adaptor 1/2" - 45
11	8	5300414	Assembly Hose
12	16	6310036	Adaptor 3/4" - 90

# GSG 125/150/200/250 ASSEMBLY HYDRAULIC - 2200307

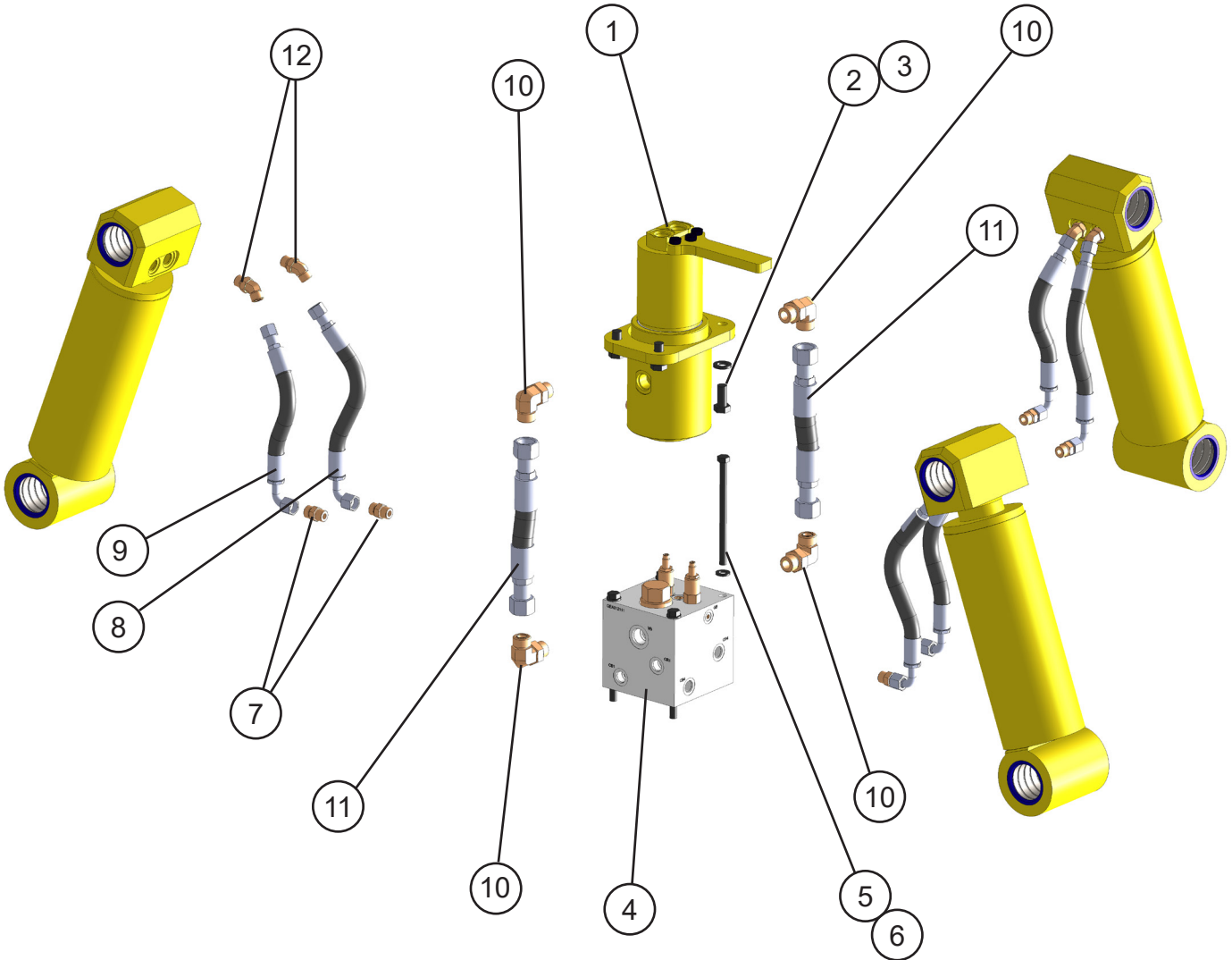

## GSG 125/150/200/250 ASSEMBLY HYDRAULIC - 2200307

ITEM	QTY	PART NUMBER	DESCRIPTION
1	1	6350039	Assembly Swivel Manifold
2	4	F0116035	Hex Head Capscrew M16 x 2.0
3	4	F1201630	Flat Washer M16
4	1	6380070	Assembly Valve Manifold
5	4	F0112180	Hex Head Capscrew M12 x 1.75
6	4	F1201224	Flat Washer M12
7	8	6300017	Adaptor ½" Straight
8	4	5300411	Assembly Hose
9	4	5300412	Assembly Hose
10	8	6310036	Adaptor ¾" - 90
11	8	5300413	Assembly Hose
12	8	6300302	Adaptor ½" - 45

# GSG 75/100/125/150/200/250 ASSEMBLY YOKE (FORKED STICK)

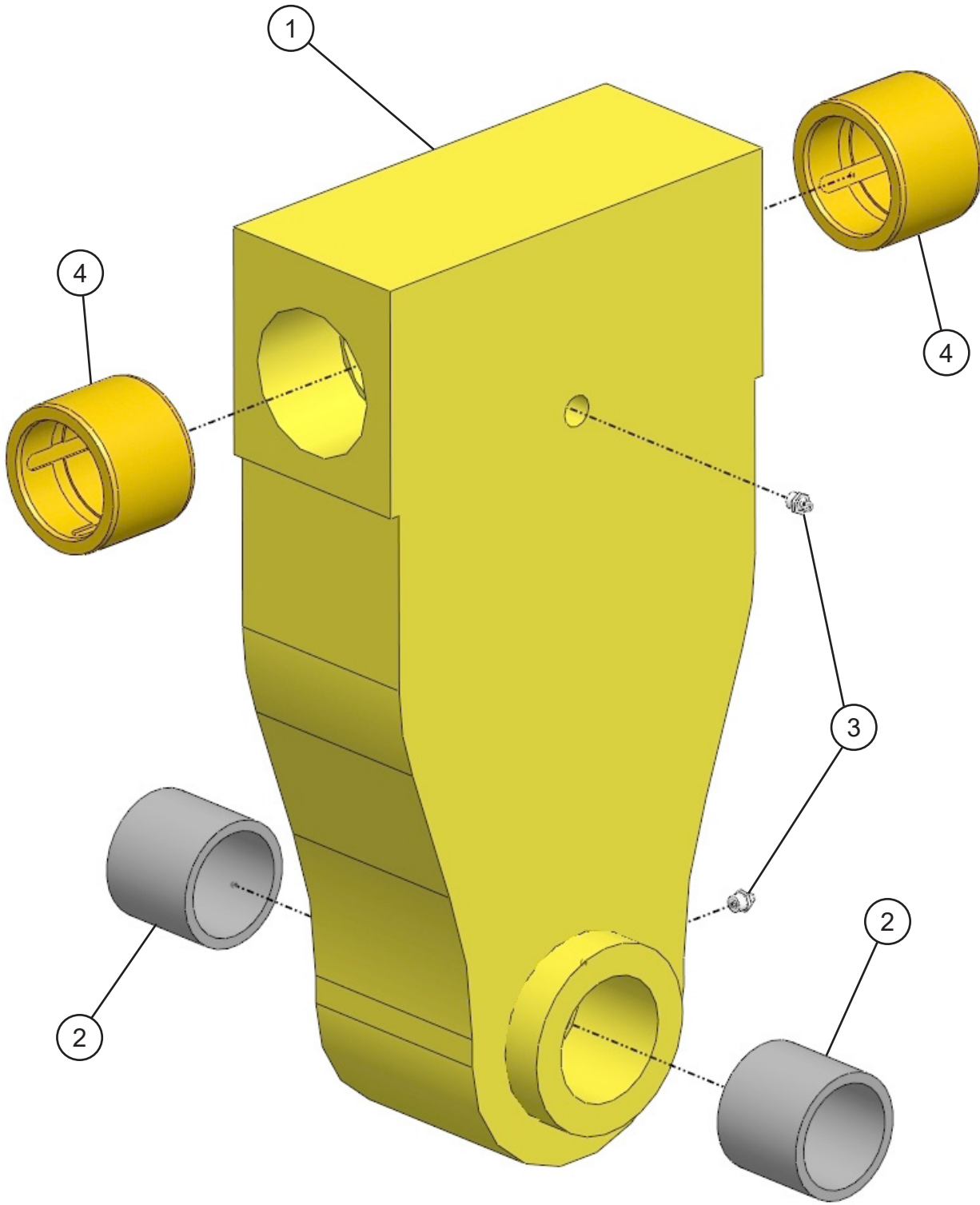

## GSG 75/100/125/150/200/250 ASSEMBLY YOKE (FORKED STICK)

ITEM	QTY	PART NUMBER	DESCRIPTION
1	1	* Note below	Wtmg Yoke
2	2		Mach Bearing
3	2		Grease Fitting
4	2		Mach Bearing

\*Yoke part numbers are Serial Number specific. For replacement parts call the Genesis Parts Department.

**USA**

715-395-5614  
715-395-3405

**Europe**

+49 83 31 9 25 98 0

# GSG 75/100/125/150/200/250 ASSEMBLY YOKE

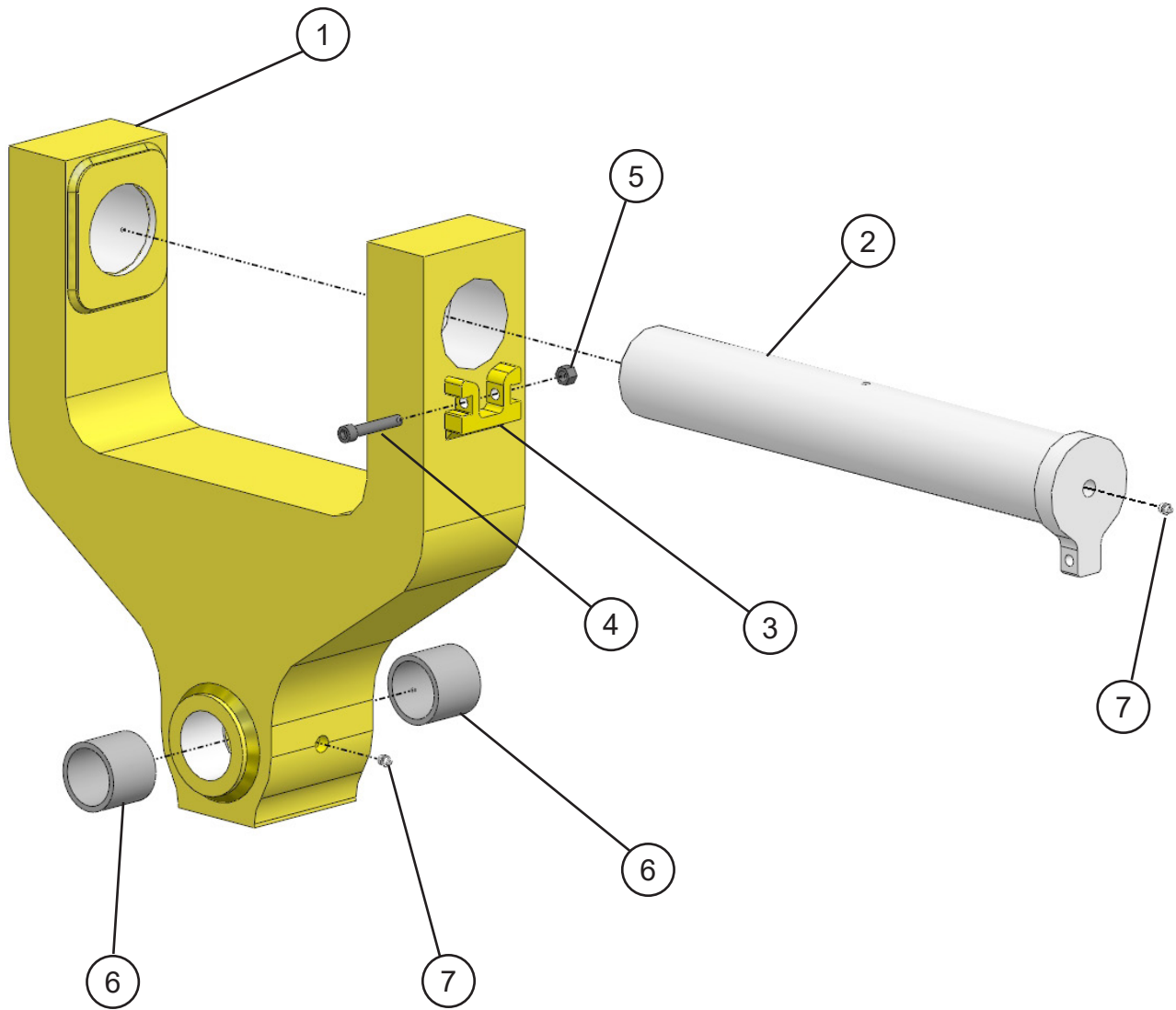



## GSG 75/100/125/150/200/250 ASSEMBLY YOKE

ITEM	QTY	PART NUMBER	DESCRIPTION
1	1	* Note below	Wtmg Yoke
2	2		Wldt Pin Drill
3	2		Mach Pin Keeper
4	2		Socket Head Capscrew
5	2		Nylock Hex Head
6	2		Mach Bearing
7	2		Grease Fitting

\*Yoke part numbers are Serial Number specific. For replacement parts call the Genesis Parts Department.

**USA**

715-395-5614  
715-395-3405

**Europe**

+49 83 31 9 25 98 0

## BOLT TORQUE SPECIFICATIONS

Reference the product Thread Treatment Diagrams on page 27 to determine whether to use wet or dry torque values for specific bolts.

Reference Procedures on page 28 for threadlocker or anti-seize application and bolt and bolt hole cleaning.

Prior to torquing, clean all bolt holes, bolts and nuts to remove dirt, grease and oil, and identify bolt type.

Never re-torque bolts that use Loctite. If a bolt becomes loose or damaged after the initial use when Loctite was applied and the bolt was torqued, the bolt must be replaced.

Never break tightened bolts loose with a torque wrench. Doing so may break the torque wrench or take it out of calibration.

Torque wrenches should be calibrated on an annual basis.

When using a torque multiplier with a torque wrench, incorrect settings will be multiplied by the ratio of the torque wrench.

Never use an impact driver on a torque multiplier.

# THREAD TREATMENT DIAGRAM

## Grapples

Use this diagram to determine what thread treatment, if any, is required for each fastener.

For thread treatment application procedures, see page 28. For prescribed torque values, see page 30.

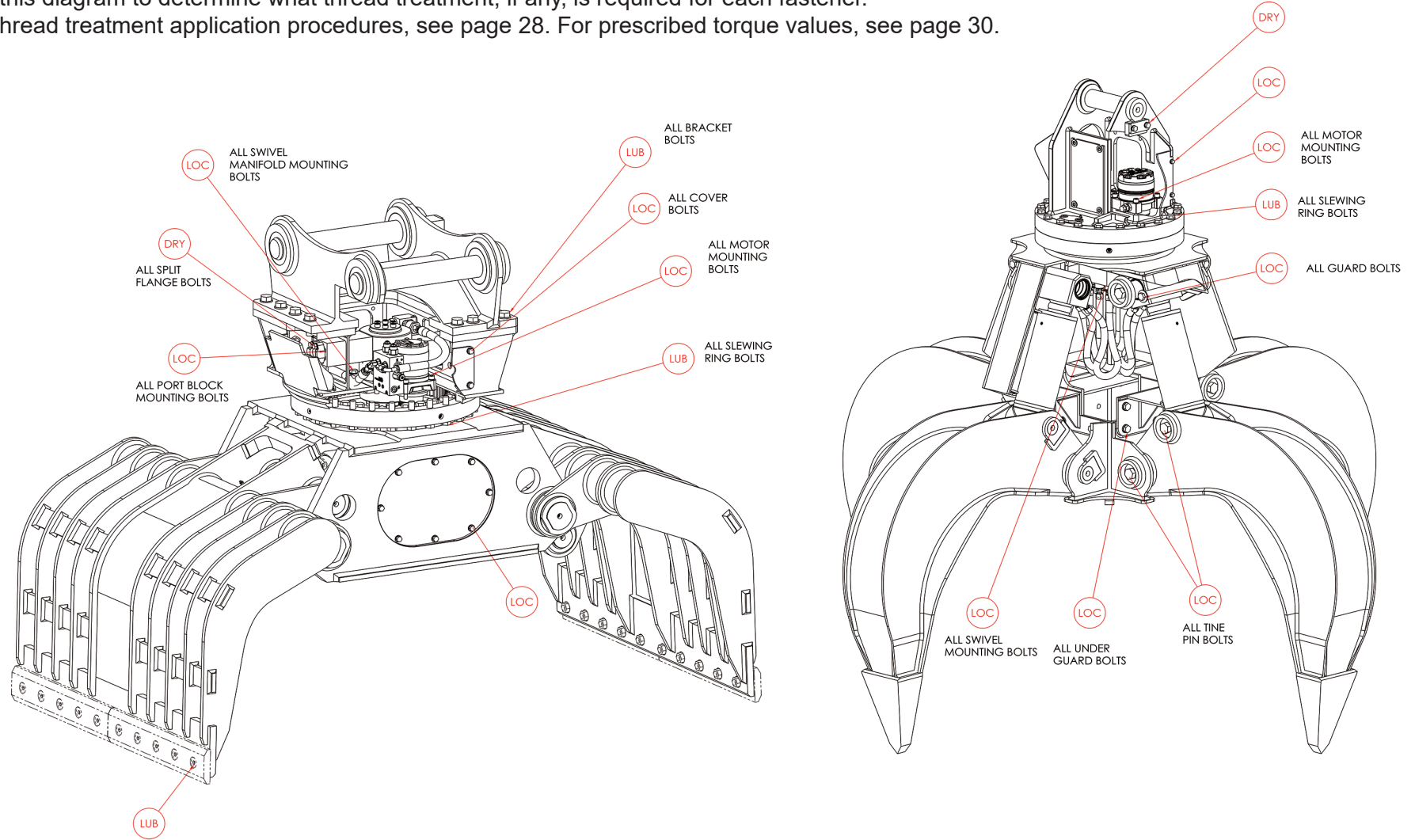

# PROCEDURES

Reference the product Thread Treatment Diagrams on page 27 to determine which of the following procedures is required.

## Cleaning

To ensure proper performance of thread treatment and accurate torque values, clean and degrease **all internal and external threads** prior to application of threadlocker, anti-seize or primer and before installation of hardware.

- Ensure both internal and external threads are free of dirt or debris.
- Use brake cleaner or similar cleaning solvent on all threads to remove any grease or oil.
- Allow threads to dry.

## NOTICE

Failure to properly clean threads will cause threadlocker, primer, and/or anti-seize to not properly cure!

LOC

## Threadlocker

For bolted connections requiring threadlocker, use **Loctite 263** or equivalent applied using the following procedure:

- Clean and degrease all threads.
- For thru holes or nuts, apply threadlocker to bolt threads.
- For blind holes, apply stripe of threadlocker along the length of the hole (applying to the bolt can cause escaping air to remove threadlocker as the bolt is inserted).
- Torque bolt to specified **Wet Torque Value**, see page 30.

For threaded hydraulic fitting connections, use **Loctite 5452** or equivalent thread sealant in conjunction with **Loctite 7471** primer using the following procedure:

- Clean and degrease all threads.
- Apply Loctite 7471 primer to both external and internal threads and allow to dry.
- Apply threadlocker to 360 degrees of the threads on the male fitting, ensuring adequate coverage.
- Assemble fitting per directions in operator's manual.
- For O-ring boss and flat face O-ring connections, torque fittings to values specified on page 31.

Threadlocker

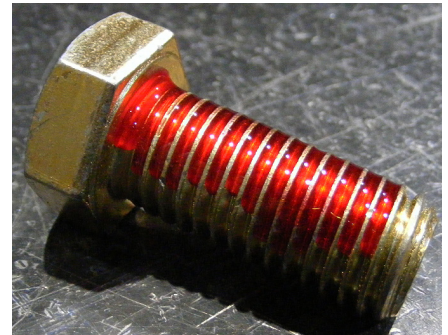

Blind Hole

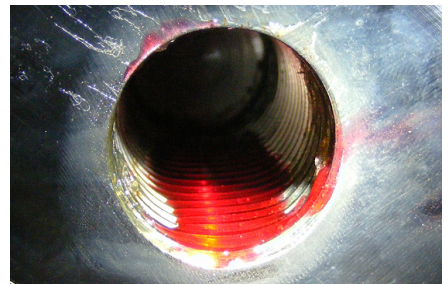

Hydraulic Fitting



# PROCEDURES

LUB

## Anti-Seize

For bolted connections requiring anti-seize lubrication, use **Loctite LB8008** or equivalent using the following procedure:

- Clean and degrease all threads.
- Apply thin coat of anti-seize to internal and external threads and under bolt head and/or nut, ensuring complete coverage.
- Torque bolt to specified **Wet Torque Value**, see page 30.

Anti-Seize









DRY

## No Thread Treatment

- Clean and degrease all threads.
- Torque bolt to specified **Dry Torque Value**, see page 30.

# BOLT TORQUE SPECIFICATIONS

<b>Dry Torque Values</b>					
		Hex/Socket Head		Flat Head	
		 			
Fastener Grade	Size x Pitch	Nm	Ft-lb	Nm	Ft-lb
CL 10.9	M8 x 1.25	35	26	27	20
	M10 x 1.50	71	53	58	42
	M12 x 1.75	124	92	101	73
	M14 x 1.50	200	148	163	118
	M14 x 2.00	200	148	163	118
	M16 x 2.00	311	230	254	184
	M20 x 1.50	610	450	498	360
	M20 x 2.50	608	449	497	359
	M24 x 3.00	1054	778	861	622
	M27 x 3.00	1543	1138	1260	910
	M30 x 3.50	2095	1545	1712	1236
	M36 x 4.00	3659	2699	2991	2159
8	1/4-20	14	11	11	8
	5/16-18	32	24	26	19
	3/8-16	59	44	48	35
	7/16-14	94	70	77	56
	1/2-13	143	106	116	84
	1/2-20	162	120	133	96
	5/8-11	287	212	234	169
	3/4-10	509	376	415	300
	7/8-9	821	606	670	484
	1.00-8	1232	909	1007	727
	1.00-14	1383	1020	1130	816
	1.25-7	2463	1817	2013	1453
L9	1.50-6	4287	3162	3504	2529

<b>Wet Torque Values</b>					
		Hex/Socket Head		Flat Head	
		 			
Fastener Grade	Size x Pitch	Nm	Ft-lb	Nm	Ft-lb
CL 10.9	M8 x 1.25	29	22	23	17
	M10 x 1.50	61	45	49	36
	M12 x 1.75	105	78	85	62
	M14 x 1.50	150	111	121	88
	M14 x 2.00	170	126	138	100
	M16 x 2.00	265	196	216	156
	M20 x 1.50	456	337	372	269
	M20 x 2.50	517	382	422	305
	M24 x 3.00	894	660	731	528
	M27 x 3.00	1312	968	1072	774
	M30 x 3.50	1779	1312	1453	1049
	M36 x 4.00	3110	2294	2542	1835
8	1/4-20	13	10	11	8
	5/16-18	27	20	22	16
	3/8-16	50	37	40	29
	7/16-14	80	59	65	47
	1/2-13	122	90	99	72
	1/2-20	138	102	112	81
	5/8-11	244	180	199	144
	3/4-10	433	320	354	256
	7/8-9	698	515	570	412
	1.00-8	1046	772	854	617
	1.00-14	1175	867	960	693
	1.25-7	2095	1545	1712	1236
L9	1.50-6	3644	2688	2979	2150

# O-RING BOSS & FLAT FACE O-RING TORQUE SPECIFICATIONS

O-Ring Boss Torque Values		
Size Dash	Nm	Ft-lb
-4	22	16
-5	27	20
-6	36	26
-8	83	60
-10	110	80
-12	187	135
-14	249	180
-16	304	220
-20	387	280
-24	498	360

Flat Face O-Ring Torque Values		
Size Dash	Nm	Ft-lb
-4	18	13
-6	30	22
-8	60	44
-10	85	62
-12	121	88
-14	121	88
-16	160	116
-20	213	154
-24	274	198

# BOLT DRIVE SPECIFICATIONS

Thread Size x Pitch	Hex Head	Socket Head	Flat Head
			
<b>Wrench/Drive Size</b>			
M8 x 1.25	13mm	6mm	5mm
M10 x 1.50	17mm	8mm	6mm
M12 x 1.75	19mm	10mm	8mm
M14 x 1.50	22mm	12mm	10mm
M14 x 2.00	22mm	12mm	10mm
M16 x 2.00	24mm	14mm	10mm
M20 x 1.50	30mm	17mm	12mm
M20 x 2.50	30mm	17mm	12mm
M24 x 3.00	36mm	19mm	14mm
M27 x 3.00	41mm	19mm	-
M30 x 3.50	46mm	22mm	-
M36 x 4.00	55mm	27mm	-
1/4-20	7/16"	3/16"	5/32"
5/16-18	1/2"	1/4"	3/16"
3/8-16	9/16"	5/16"	7/32"
7/16-14	5/8"	3/8"	1/4"
1/2-13	3/4"	3/8"	5/16"
1/2-20	3/4"	3/8"	5/16"
5/8-11	15/16"	1/2"	3/8"
3/4-10	1-1/8"	5/8"	1/2"
7/8-9	1-5/16"	3/4"	9/16"
1.00-8	1-1/2"	3/4"	5/8"
1.00-14	1-1/2"	3/4"	5/8"
1.25-7	1-7/8"	7/8"	7/8"
1.50-6	2-1/4"	1"	1"



# WARRANTY

## **Claim Procedure**

Notify the Genesis Service Department of the potential warranty claim prior to making the repair. Digital pictures are very helpful for diagnosing problems and recommending repairs.

Contact the Genesis Service Department before making alterations, changes or repairs to any component that is going to be considered for warranty. Not doing so will void all Genesis warranty consideration.

The Genesis Service Department will issue an authorization number to track the repair costs, outgoing parts, and/or defective parts returning to the factory.

Replacement parts must be ordered using a purchase order number. Shipping is standard ground. Overnight shipping is available by request, and Genesis will not cover the shipping charge.

When the repair is complete, submit an invoice to the Genesis Service Department within 30 days. Include itemized internal labor reporting, parts lists and invoices for outside contractors. Reference the authorization number on all invoices.

When returning parts for warranty consideration, include a copy of any related Genesis paperwork along with any other necessary documentation to ensure proper processing and credit. The Genesis Service Department will provide the necessary forms.

Your account will be credited when the warranty claim is accepted.

## **Blade Warranty**

Standard warranty on blades will only be considered on the first edge, and wear on the edge must be 1/8" radius or less. Genesis does not warranty cutting blades that are cracked or broken from top to bottom (perpendicular to the long edge of the blade). Genesis also does not cover fasteners, the labor to replace wear components or collateral damage, such as blade seats, from broken blades, the piercing blade tang or adjustment plates.

**Please direct any questions to the Genesis Service Department: 715-395-5252**

# PARTS ORDER POLICY AND PROCEDURE

## **Parts Orders Should Include**

- Purchase order number
- Model and serial number of attachment
- Part number and quantity needed
- Shipping and billing address
- Method of shipment or required delivery date

## **Placing Orders**

Orders may be placed by phone or e-mail. To e-mail an order, use the form on the following page or your purchase order form. Contact information is located at the front of this manual.

## **Part Numbers**

Part numbers are listed in a separate Parts Manual or, if included, the Parts section of this manual. Contact the Genesis Parts Department with questions regarding part numbers, availability and pricing.

## **Shipping**

All orders will be shipped best way surface unless an alternate shipping method is requested. Shipping charges are not included in the purchase price of parts.

## **Invoices**

All invoices are due upon receipt. Any accounts with invoices open beyond 60 days are subject to review and may be placed on C.O.D. status without further notice.

## **Returns**

Many unused Genesis parts may be returned with proper documentation. Return shipping is the responsibility of the purchaser. Credit will be issued upon return, less a 25% restocking fee. Documentation is required for credit of returned parts. Contact the Genesis Service Department at 715-395-5252 for an RGA (Return Goods Authorization) number and form. An RGA must accompany every return. Items shipped without an RGA may be returned to sender.

## **Warranty Returns**

All parts returned to Genesis for warranty consideration must be returned with a completed RGA (Return Goods Authorization) provided by the Genesis Service Department. The form needs to be completed in its entirety, including any additional information requested by the Service Department. Return shipping is the responsibility of the sender and will be credited upon claim approval. A determination to accept or deny the claim will be made based upon the information available to Genesis. Warranty on purchased parts other than wear components is 6 months. Genesis does not cover labor costs to replace purchased parts replaced under warranty. There is no warranty period on wear parts or components.



# INDEX

- 2200221 Mach Guard Mount Bar 1.25 Rnd 5, 7  
 2200231 Plt Boss 4.00 x 2.88 x 1.00 5, 7  
 2200232 Mach Washer 1.00 x 2.75 x .19 5, 7  
 2200234 Plt Pin Keeper 5, 7  
 2200235 Wtmg Frame GSG 125/150/200 7  
 2200257 Wtmg Frame GSG 75/100 5  
 2200291 Wtmg, Head GSG 75/100/125/150 - Genesis 11  
 2200293 Plt, Torque Arm Stop - GSG Head 11  
 2200298 Plt, End Cover - GSG 75/100/125/150 Head 11  
 2200299 Plt, Bolt Cover - GSG Head 11  
 2200300 Plt, Side Cover - GSG Head 11  
 2200301 Wldt, Pin - Std 11  
 2200304 Mach, Pin Keeper - GSG Head 11  
 2200306 Plt, Bar Strap - GSG Head 11  
 2200307 Assy Hyd GSG 125/150/200 7  
 2200308 Assy Hyd GSG 75/100 5  
 2200401 Wldt Pin 2.50 x 11.75 5, 7  
 2200404 Wldt Pin 2.50 x 8.125 5, 7  
 5300411 Assembly Hose 21  
 5300412 Assembly Hose 21  
 5300413 Assembly Hose 21  
 5300414 Assembly Hose 19  
 5300415 Assembly Hose 19  
 5300416 Assembly Hose 19  
 6200002 Grease Fitting 1/8-27 NPT 11  
 6300017 Adaptor 1/2" Straight 19, 21  
 6300094 Compression Connector 1/4 Tube - 18NPT 11  
 6300302 Adaptor 1/2" - 45 19, 21  
 6300303 Adaptor 1/2" - 90 11  
 6300900 Bearing, Slewing 11  
 6300901 Pinion GSG 13 Tooth 11  
 6300902 Cartridge, Crossport Relief 11  
 6300924 Socket Head Capscrew (1/2-20) 13, 15  
 6300925 Set Screw (5/16-18) 13, 15  
 6300926 Port Plug (3/4-16) 13, 15  
 6300927 Steel Spacer 13, 15  
 6300928 Fiber Bushing 13, 15  
 6300929 Pin Wiper 13, 15  
 6300930 Bearing Ring, Piston 13, 15  
 6300931 O-Ring 13, 15  
 6300932 Vented Back Up Washer 13, 15  
 6300933 Capped T-Seal 13, 15  
 6300934 O-Ring 13, 15  
 6300935 Back Up Washer 13, 15  
 6300936 Bearing Ring, Gland 13, 15  
 6300937 Buffer Seal 13, 15  
 6300938 Deep Z-Seal 13, 15  
 6300940 O-Ring 13, 15  
 6300941 Canned Wiper 13, 15  
 6300942 Packing Kit 13  
 6300949 Housing ASM 2 Circuit 17  
 6300950 Ring, Wear 17  
 6300951 Ring, Retaining 17  
 6300952 HHCS M12 x 1.75 x 45mm Gr 10.9 ZC 17  
 6300953 Washer, Flat 3.28 STL .120 17  
 6300954 Wiper, Sgl Lip for 4.00 Rod 17  
 6300955 Wiper, Sgl Lip for 3.25 Rod 17  
 6300956 Seal, U-Cup 17  
 6300957 Ring, Wear 17  
 6300958 Seal, Piston 17  
 6300959 Energizer, Sq 17  
 6300960 Washer, Thrust 17  
 6300961 Spool - 2 Circuit 17  
 6300962 Arm, Torque .62 x 7.12 STL 17  
 6300963 Tape, Installation - Seal 24" Long 17  
 6300965 Seal Kit 17  
 6300966 Pressure Relief Valve - 500 PSI (Port W) 17  
 6300976 Packing Kit 15  
 6310034 Adaptor 3/4" - 45 11  
 6310036 Adaptor 3/4" - 90 19, 21  
 6340010 Motor, Grapple Rotate 11  
 6350036 Assembly Cylinder B4.5 R3.0 S8.0 GSG 75/100 7  
 6350037 Assembly Cylinder B4.5 R3.0 S8.0 5  
 6350039 Assembly Swivel Manifold 19, 21  
 6350048 Piston Tube Assembly 13  
 6350049 Butt & Tube Assembly 13  
 6350050 Piston 13, 15  
 6350051 Gland 13, 15  
 6350052 Piston Tube Assembly 15  
 6350053 Butt & Tube Assembly 15  
 6380070 Assembly Valve Manifold 19, 21  
 Assembly Tine Kit, Point, Narrow 2200311 9  
 Bolt Drive Specifications 32  
 Bolt Torque Specifications 26, 30  
 Contact Information 2, 38  
 F0112030 Hex Head Capscrew M12 x 1.75 11  
 F0112180 Hex Head Capscrew M12 x 1.75 19, 21  
 F0116030 Hex Head Capscrew M16 x 2.0 5, 7  
 F0116035 Hex Head Capscrew M16 x 2.0 19, 21  
 F0116080 Hex Head Capscrew M16 x 2 x 80 11  
 F0124050 Hex Head Capscrew M24 x 3 x 50 5, 7  
 F0375201 Hex Head Capscrew .63 x 11 x 1.00 11  
 F0612070 Socket Head Capscrew M12 x 1.75 11  
 F1201224 Flat Washer M12 11, 19, 21  
 F1201630 Flat Washer M16 5, 7, 11, 19, 21  
 F1310058 Flat Washer Wide .58 x 1.75 OD USS 5, 7  
 Grease Fitting 23, 25  
 GSG 75/100/125/150/200/250 Assembly Swivel - 6350039 16, 17  
 GSG 75/100/125/150/200/250 Assembly Tine Kits 8, 9  
 GSG 75/100/125/150/200/250 Assembly Upper Head - 2200290 10, 11  
 GSG 75/100/125/150/200/250 Assembly Yoke 24, 25  
 GSG 75/100/125/150/200/250 Assembly Yoke (Forked Stick) 22, 23

# INDEX

GSG 75/100 Assembly Cylinder B4.5 R3.0 S8.0 - 6350037	12, 13	GSG 200 Assembly Tine Kit, Point, Medium 2200383	9
GSG 75/100 Assembly Grapple Tower - 2200233	5	GSG 200 Assembly Tine Kit, Point, Narrow 2200393	9
GSG 75/100 Assembly Hydraulic - 2200308	18, 19	GSG 200 Wtmg Tine, Flat, Medium 2200396	9
GSG 75/100 Flat Tine Outer Guard 2200317	9	GSG 200 Wtmg Tine, Flat, Narrow 2200391	9
GSG 75/100 Flat Tine Under Guard 2200325	9	GSG 200 Wtmg Tine, Point, Medium 2200278	9
GSG 75/100 Point Tine Outer Guard 2200275	9	GSG 200 Wtmg Tine, Point, Narrow 2200284	9
GSG 75/100 Point Tine Under Guard 2200279	9	GSG 250 Assembly Tine Kit, Flat, Medium 2200431	9
GSG 75 Assembly Tine Kit, Flat, Medium 2200374	9	GSG 250 Assembly Tine Kit, Flat, Narrow 2200432	9
GSG 75 Assembly Tine Kit, Flat, Narrow 2200370	9	GSG 250 Assembly Tine Kit, Point, Medium 2200429	9
GSG 75 Assembly Tine Kit, Point, Medium 2200313	9	GSG 250 Assembly Tine Kit, Point, Narrow 2200430	9
GSG 75 Assembly Tine Kit, Point, Narrow 2200309	9	GSG 250 Wtmg Tine, Flat, Medium 2200427	9
GSG 75 Wtmg Tine, Flat, Medium 2200339	9	GSG 250 Wtmg Tine, Flat, Narrow 2200428	9
GSG 75 Wtmg Tine, Flat, Narrow 2200330	9	GSG 250 Wtmg Tine, Point, Medium 2200425	9
GSG 75 Wtmg Tine, Point, Medium 2200265	9	GSG 250 Wtmg Tine, Point, Narrow 2200426	9
GSG 75 Wtmg Tine, Point, Narrow 2200285	9	Mach Bearing	23, 25
GSG 100 Assembly Tine Kit, Flat, Medium 2200375	9	Mach Bearing 2200406	9
GSG 100 Assembly Tine Kit, Flat, Narrow 2200371	9	Mach Pin Keeper	25
GSG 100 Assembly Tine Kit, Point, Medium 2200314	9	Nylock Hex Head	25
GSG 100 Assembly Tine Kit, Point, Narrow 2200310	9	O-Ring Boss & Flat Face O-Ring Torque Specifications	31
GSG 100, Wtmg Tine, Flat, Medium 2200347	9	Parts Order Form	35
GSG 100 Wtmg Tine, Flat, Narrow 2200341	9	Parts Order Policy and Procedure	34
GSG 100 Wtmg Tine, Point, Medium 2200270	9	Procedures	28, 29
GSG 100 Wtmg Tine, Point, Narrow 2200287	9	Seal 6300899	9
GSG 125/150/200/250 Assembly Cylinder B4.5 R3.0 S10.0 - 6350036	14, 15	Socket Head Capscrew	25
GSG 125/150/200/250 Assembly Grapple Tower - 2200289	6, 7	Table of Contents	3
GSG 125/150/200/250 Assembly Hydraulic - 2200307	21	Thread Treatment Diagram	27
GSG 125/150 Flat Tine Outer Guard 2200321	9	Warranty	33
GSG 125/150 Flat Tine Under Guard 2200327	9	Wldt Pin Drill	25
GSG 125/150 Point Tine Outer Guard 2200246	9	Wtmg Yoke	23, 25
GSG 125/150 Point Tine Under Guard 2200222	9		
GSG 125 Assembly Tine Kit, Flat, Medium 2200376	9		
GSG 125 Assembly Tine Kit, Flat, Narrow 2200372	9		
GSG 125 Assembly Tine Kit, Point, Medium 2200315	9		
GSG 125 Wtmg Tine, Flat, Medium 2200357	9		
GSG 125 Wtmg Tine, Flat, Narrow 2200349	9		
GSG 125 Wtmg Tine, Point, Medium 2200190	9		
GSG 125 Wtmg Tine, Point, Narrow 2200281	9		
GSG 150 Assembly Tine Kit, Flat, Medium 2200377	9		
GSG 150 Assembly Tine Kit, Flat, Narrow 2200373	9		
GSG 150 Assembly Tine Kit, Point, Medium 2200316	9		
GSG 150 Assembly Tine Kit, Point, Narrow 2200312	9		
GSG 150 Wtmg Tine, Flat, Medium 2200364	9		
GSG 150 Wtmg Tine, Flat, Narrow 2200359	9		
GSG 150 Wtmg Tine, Point, Medium 2200260	9		
GSG 150 Wtmg Tine, Point, Narrow 2200283	9		
GSG 200/250 Flat Tine Outer Guard 2200321	9		
GSG 200/250 Flat Tine Under Guard 2200327	9		
GSG 200/250 Point Tine Outer Guard 2200246	9		
GSG 200/250 Point Tine Under Guard 2200222	9		
GSG 200 Assembly Tine Kit, Flat, Medium 2200394	9		
GSG 200 Assembly Tine Kit, Flat, Narrow 2200395	9		



**GENESIS®**

The Promise of Performance.

## CONTACT INFORMATION

### Genesis Attachments

1000 Genesis Drive  
Superior, WI 54880 USA

Toll Free: 888-SHEAR-IT  
(888-743-2748)

Phone: 715.395.5252

E-mail:  
info@genesisattachments.com

### Europe/Africa/Middle East Genesis GmbH

Teramostrasse 23  
87700 Memmingen, Germany

Phone: +49 83 31 9 25 98 0

Fax: +49 83 31 9 25 98 80

genesis-europe.com

E-mail:  
info@genesis-europe.com

### Asia Pacific Representative Office

24 Upper Serangoon View #12-28  
Singapore 534205

Phone: +65 9673 9730

E-mail:  
tchoo@genesisattachments.com

### Central America & Colombia

Cra 13A #89-38 / Ofi 613  
Bogota, Colombia

Phone: +57 1 610 8160 / 795 8747

E-mail:  
contact@themsagroup.com

View and download all manuals: [genesisattachments.com/manuals](http://genesisattachments.com/manuals)  
Patents: [genesisattachments.com/products/patents](http://genesisattachments.com/products/patents)