

GSS 2500 Subsea Shear

PARTS MANUAL

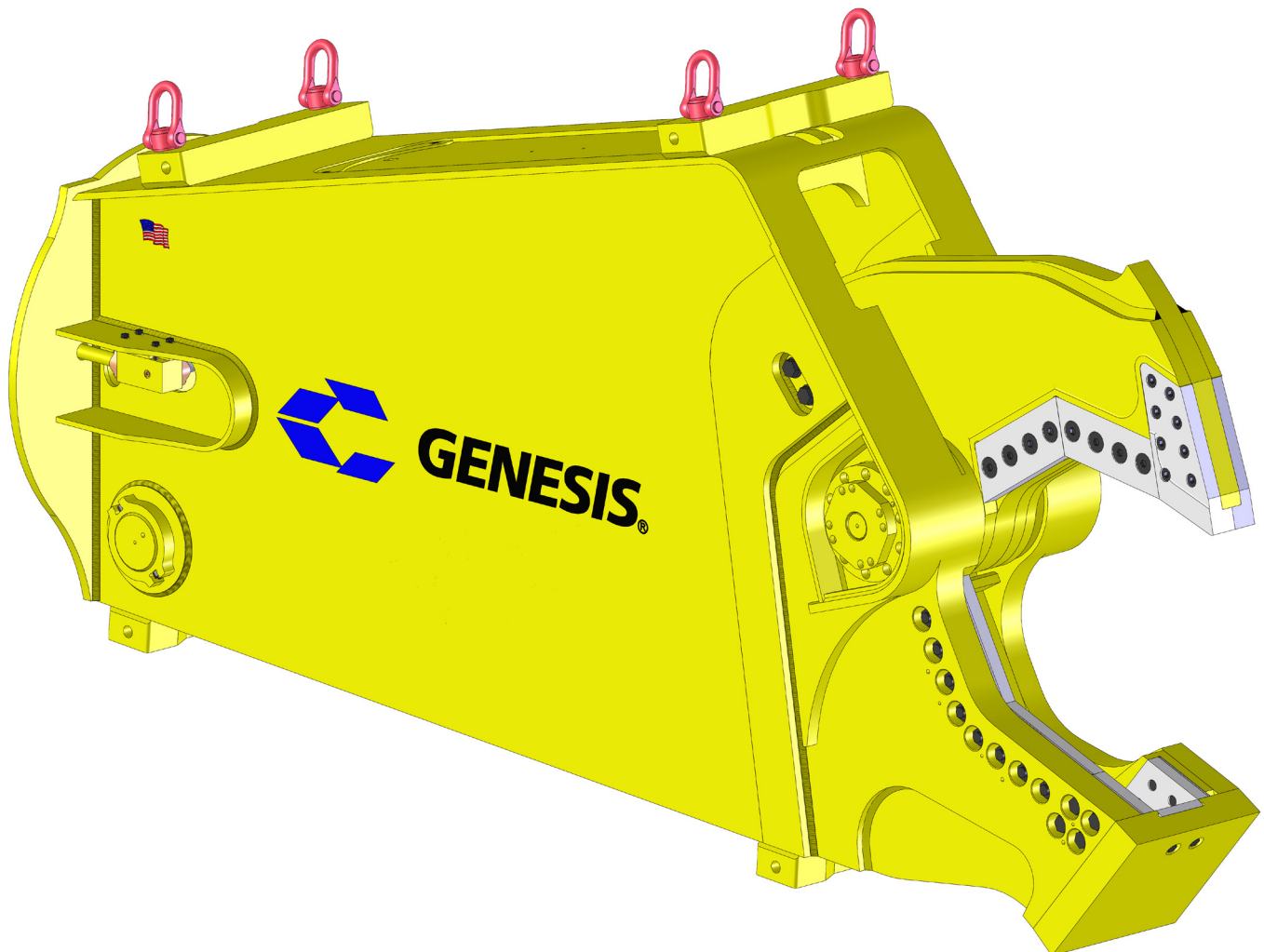

CONTACT INFORMATION

Genesis Attachments

1000 Genesis Drive
Superior, WI 54880 USA

Toll Free: 888-SHEAR-IT
(888-743-2748)

Phone: 715.395.5252

E-mail:
info@genesisattachments.com

Europe/Africa/Middle East Genesis GmbH

Teramostrasse 23
87700 Memmingen, Germany

Phone: +49 83 31 9 25 98 0
Fax: +49 83 31 9 25 98 80
genesis-europe.com

E-mail:
info@genesis-europe.com

Asia Pacific Representative Office

24 Upper Serangoon View #12-28
Singapore 534205

Phone: +65 9673 9730

E-mail:
tchoo@genesisattachments.com

Central America & Colombia

Cra 13A #89-38 / Ofi 613
Bogota, Colombia

Phone: +57 1 610 8160 / 795 8747

E-mail:
contact@themsagroup.com

View and download all manuals: genesisattachments.com/manuals
Patents: genesisattachments.com/products/patents

TABLE OF CONTENTS

CONTACT INFORMATION	2
GENERAL ARRANGEMENT	4
ASSEMBLY PIVOT GROUP - RIGHT HAND SIDE	6
ASSEMBLY PIVOT GROUP - LEFT HAND SIDE	8
ASSEMBLY LOWER SHEAR BLADES	10
ASSEMBLY UPPER SHEAR BLADES	12
ASSEMBLY AUTO GUIDE	14
ASSEMBLY CYLINDER PINS	16
ASSEMBLY ACCESS COVERS	18
ASSEMBLY CYLINDER - 6350041	20
PISTON SEAL ARRANGEMENT	22
GLAND SEAL ARRANGEMENT	24
SUB-ASSEMBLY CYLINDER - 1201234	26
REGEN BYPASS MANIFOLD	28
ASSEMBLY PORT BLOCK - RIGHT HAND SIDE	30
ASSEMBLY PORT BLOCK - LEFT HAND SIDE	32
BOLT TORQUE SPECIFICATIONS	34
THREAD TREATMENT DIAGRAM	35
Mobile Shears	35
PROCEDURES	36
Cleaning	36
Threadlocker	36
Anti-Seize	37
No Thread Treatment	37
BOLT TORQUE SPECIFICATIONS	38
Dry Torque Values	38
Wet Torque Values	38
O-RING BOSS & FLAT FACE O-RING TORQUE SPECIFICATIONS	39
BOLT DRIVE SPECIFICATIONS	40
WARRANTY	41
Claim Procedure	41
Blade Warranty	41
PARTS ORDER POLICY AND PROCEDURE	42
Parts Orders Should Include	42
Placing Orders	42
Part Numbers	42
Shipping	42
Invoices	42
Returns	42
Return Goods Authorization	42
PARTS ORDER FORM	43
INDEX	44
CONTACT INFORMATION	46

GENERAL ARRANGEMENT

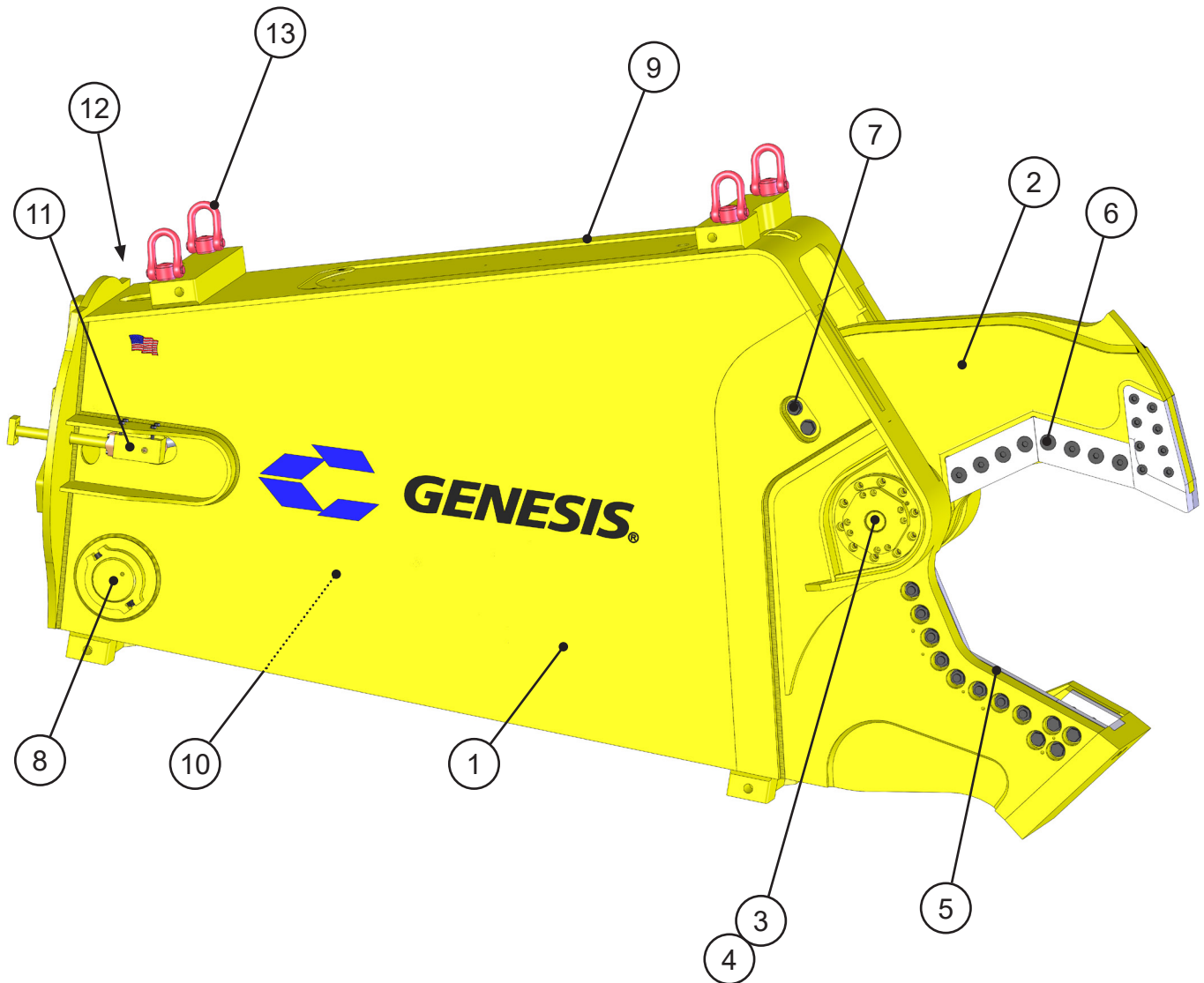

GENERAL ARRANGEMENT

ITEM	QTY	PART NUMBER	DESCRIPTION
1	1	1105077	Wtmg Stick
2	1	1105325	Wtmg Upper
3	1	See page 6	Assembly Pivot Group - Right Hand Side
4	1	See page 8	Assembly Pivot Group - Left Hand Side
5	--	See page 10	Assembly Lower Blades
6	--	See page 12	Assembly Upper Blades
7	--	See page 14	Assembly Auto Guide
8	--	See page 16	Assembly Cylinder Pins
9	--	See page 18	Assembly Access Covers
10	--	See page 26	Assembly Cylinder
11	--	See page 30	Assembly Port Block - Right Hand Side
12	--	See page 32	Assembly Port Block - Left Hand Side
13	4	6200077	Shackle Double Swing

ASSEMBLY PIVOT GROUP - RIGHT HAND SIDE

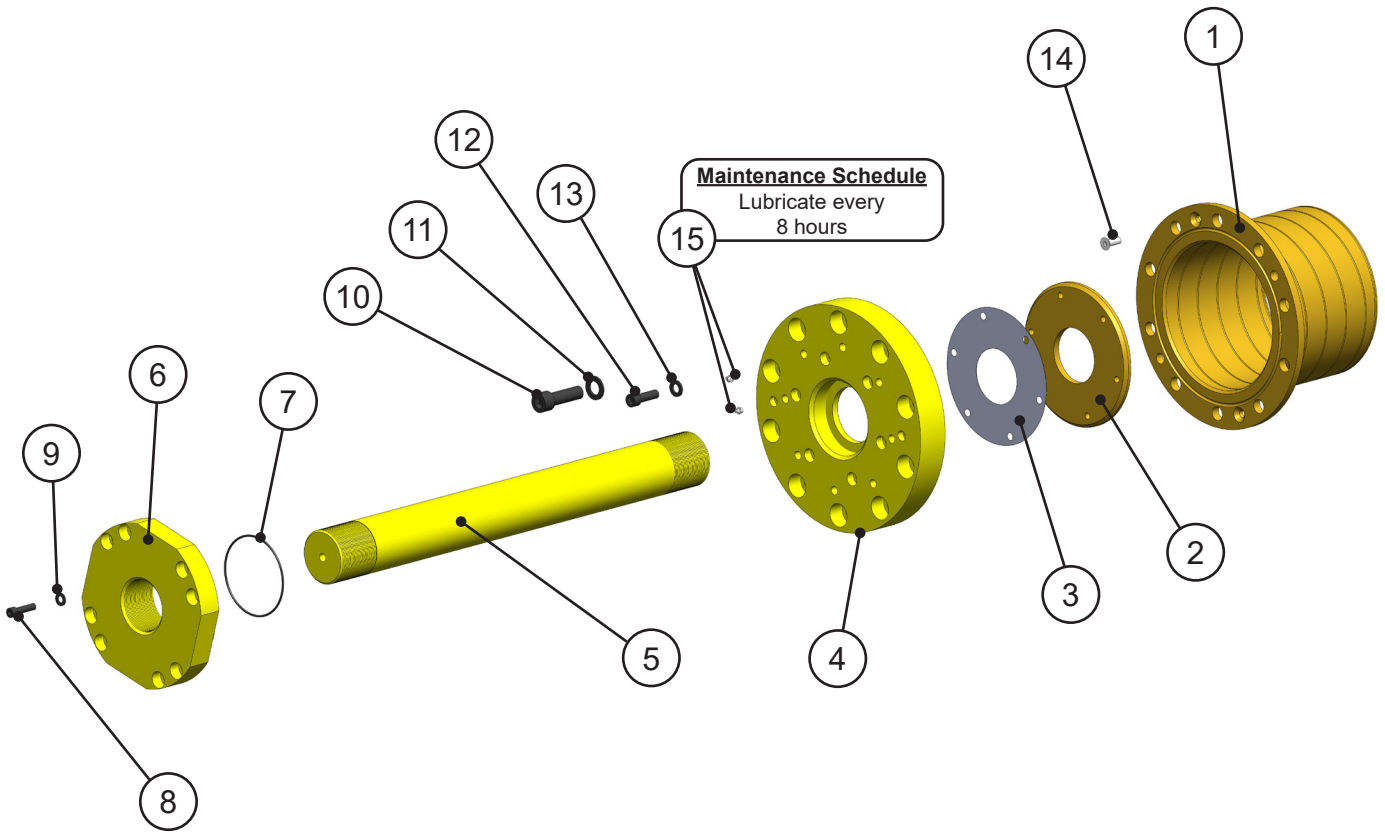

ASSEMBLY PIVOT GROUP - RIGHT HAND SIDE

ITEM	QTY	PART NUMBER	DESCRIPTION
1	1	1104052	Mach Bearing RH
2	1	1104048	Mach Thrust Washer
3	1	1104049	Shim Set Thrust Washer
4	1	1104075	Mach End Cap
5	1	1104078	Mach Tie Rod
6	1	1104081	Mach Tie Rod Nut
7	1	S0190254	O-Ring
8	4	F0616050	Socket Head Capscrew M16 x 2.00 x 50
9	4	F1201630	Flat Washer M16
10	10	F0624080	Socket Head Capscrew M24 x 3.00 x 80
11	10	F1201630	Flat Washer M16
12	6	F0612050	Socket Head Capscrew M12 x 1.75 x 50
13	6	F1201224	Flat Washer M12
14	2	F0412035	Flat Head Capscrew M12 x 1.75 x 35
15	2	6200002	Grease Fitting

ASSEMBLY PIVOT GROUP - LEFT HAND SIDE

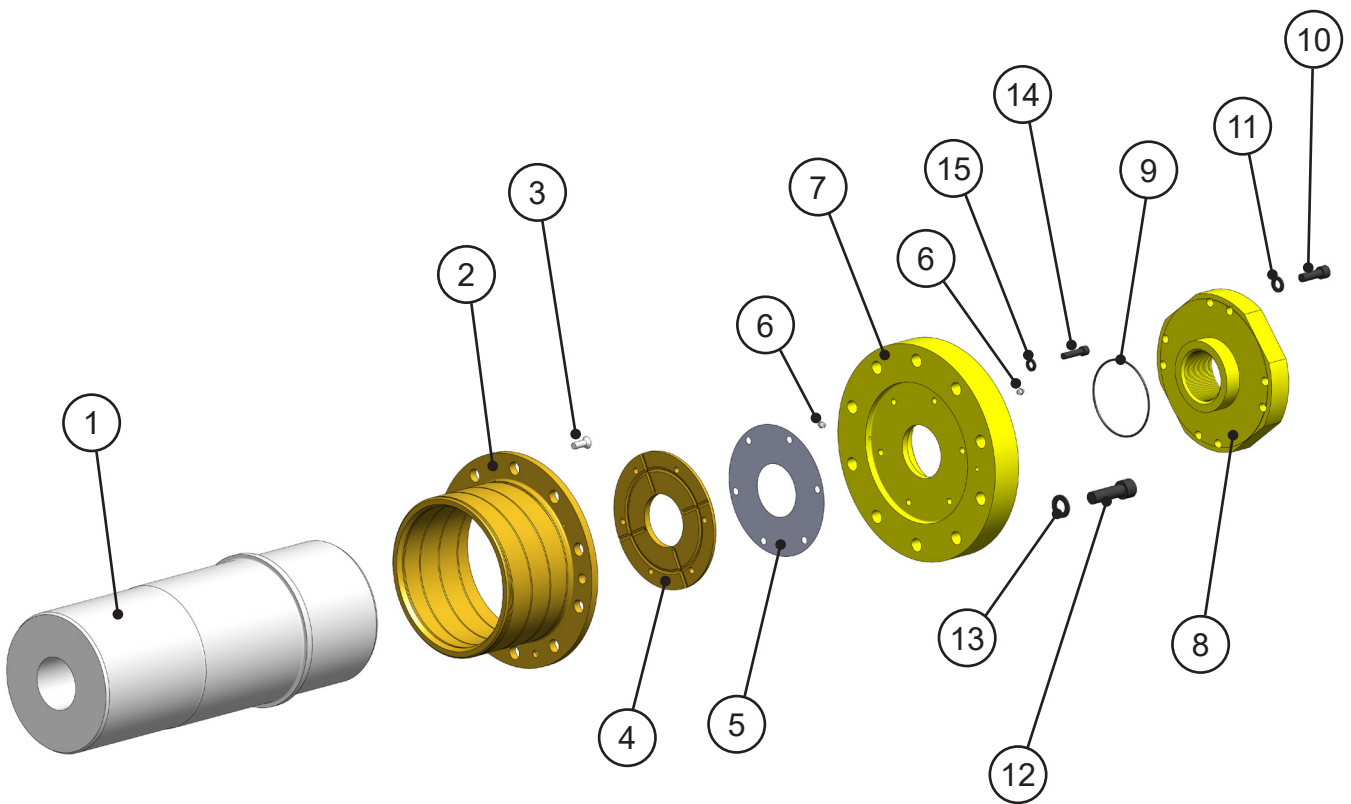

ASSEMBLY PIVOT GROUP - LEFT HAND SIDE

ITEM	QTY	PART NUMBER	DESCRIPTION
1	1	1104050	Mach Main Shaft
2	1	1104053	Mach Bearing LH
3	1	F0412035	Flat Head Capscrew M12 x 1.75 x 35
4	1	1104048	Mach Thrust Washer
5	1	1104049	Shim Set Thrust Washer
6	2	6200002	Grease Fitting
7	1	1104075	Mach End Cap
8	1	1104081	Mach Tie Rod Nut
9	1	S0190254	O-Ring
10	4	F0616050	Socket Head Capscrew M16 x 2.00 x 50
11	4	F1201630	Flat Washer M16
12	10	F0624080	Socket Head Capscrew M24 x 3.00 x 80
13	10	F1201630	Flat Washer M16
14	6	F0612050	Socket Head Capscrew M12 x 1.75 x 50
15	6	F1201224	Flat Washer M12

ASSEMBLY LOWER SHEAR BLADES

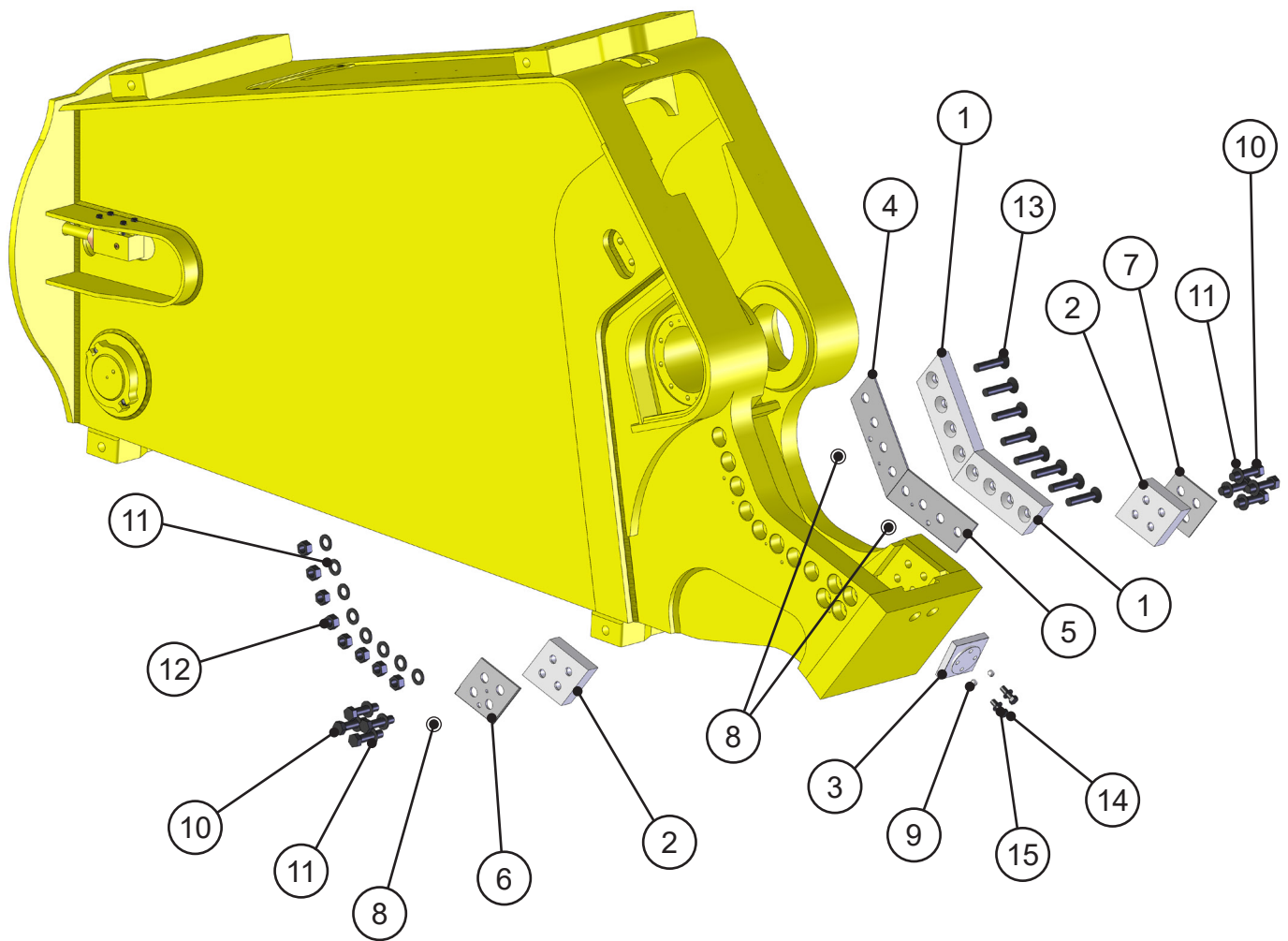

ASSEMBLY LOWER SHEAR BLADES

ITEM	QTY	PART NUMBER	DESCRIPTION
1	2	1104010	Mach Blade
2	2	1104013	Mach Blade Guide
3	1	1104073	Mach Blade Razor
4	1	1104195	Mach Adjustment Plt Primary
5	1	1104196	Mach Adjustment Plt Secondary
6	1	1105158	Mach Adjustment Plt GB
7	1	1104197	Mach Adjustment Plt Guide
8	3	6300134	Dowel Pin
9	2	F2510100	Set Screw Socket Head 1 - 8 x 1
10	8	F0215600	Hex Head Capscrew 1½ - 6 x 6
11	16	F1300150	Flat Washer 1½
12	8	F0915006	Hex Nut 1½ - 6
13	8	F0515700	Flat Head Capscrew 1½ - 6 x 7
14	2	F0210300	Hex Head Capscrew 1 - 8 x 3
15	2	F1300100	Flat Washer 1"
SHIM SETS			
		1104071	Blade Shim Set
		1104072	Guide Shim Set, Blade Side

ASSEMBLY UPPER SHEAR BLADES

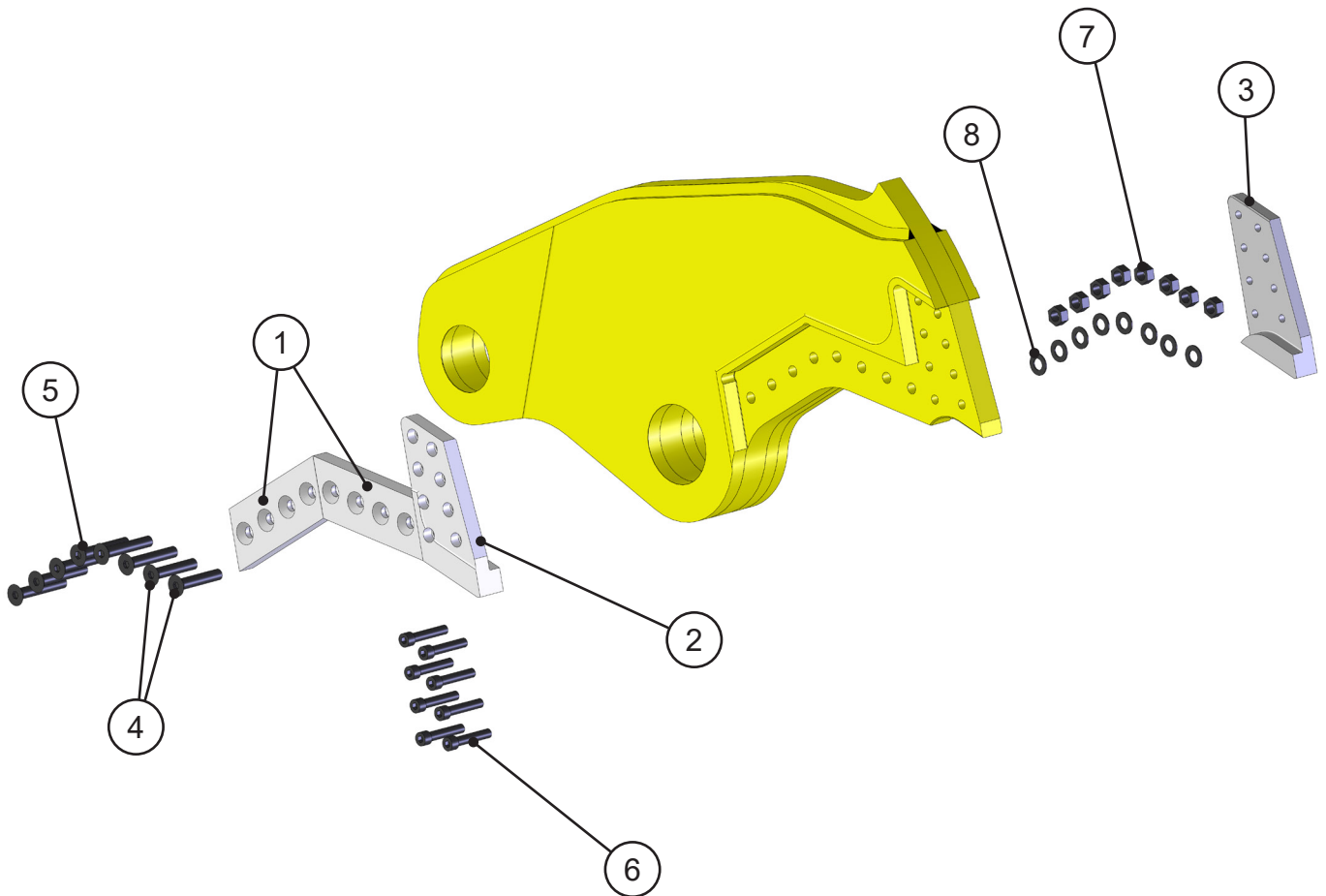

ASSEMBLY UPPER SHEAR BLADES

ITEM	QTY	PART NUMBER	DESCRIPTION
1	2	1104010	Mach Blade
2	1	1104011	Mach Blade Tip RH
3	1	1104012	Mach Blade Tip LH
4	2	F0515800	Flat Head Capscrew 1½ - 6 x 8
5	6	F0515900	Flat Head Capscrew 1½ - 6 x 9
6	8	1104143	Mach Bolt Socket Head Capscrew 1¼ - 7 x 6½
7	8	F0915006	Hex Nut 1½ - 6
8	8	F1300150	Flat Washer 1½

ASSEMBLY AUTO GUIDE

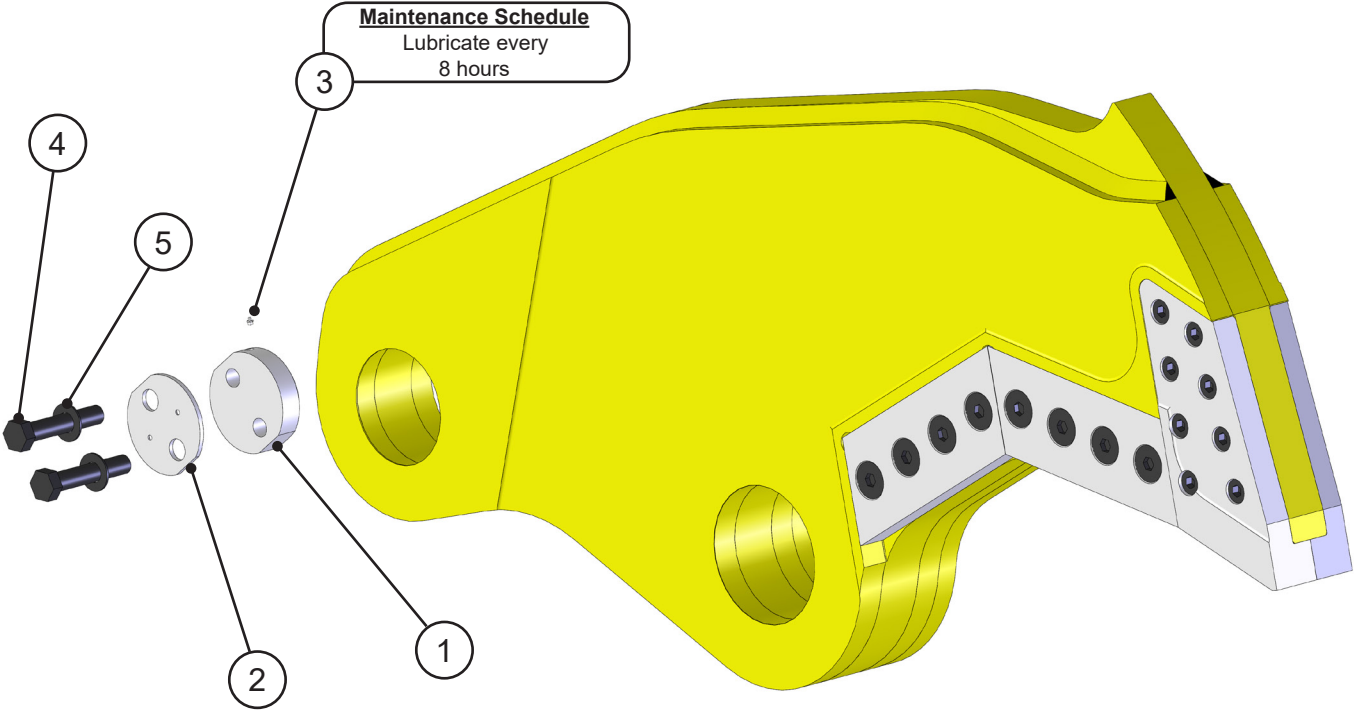

ASSEMBLY AUTO GUIDE

ITEM	QTY	PART NUMBER	DESCRIPTION
1	1	1104207	Mach Auto Guide
2	1	1104209	Mach Auto Guide Adjustment Plate
3	1	6200002	Grease Fitting
4	2	F0215800	Hex Head Capscrew 1½ - 6 x 8
5	2	F1300150	Flat Washer 1½
SHIM SET			
		1104453	Shim Set, Auto Guide

ASSEMBLY CYLINDER PINS

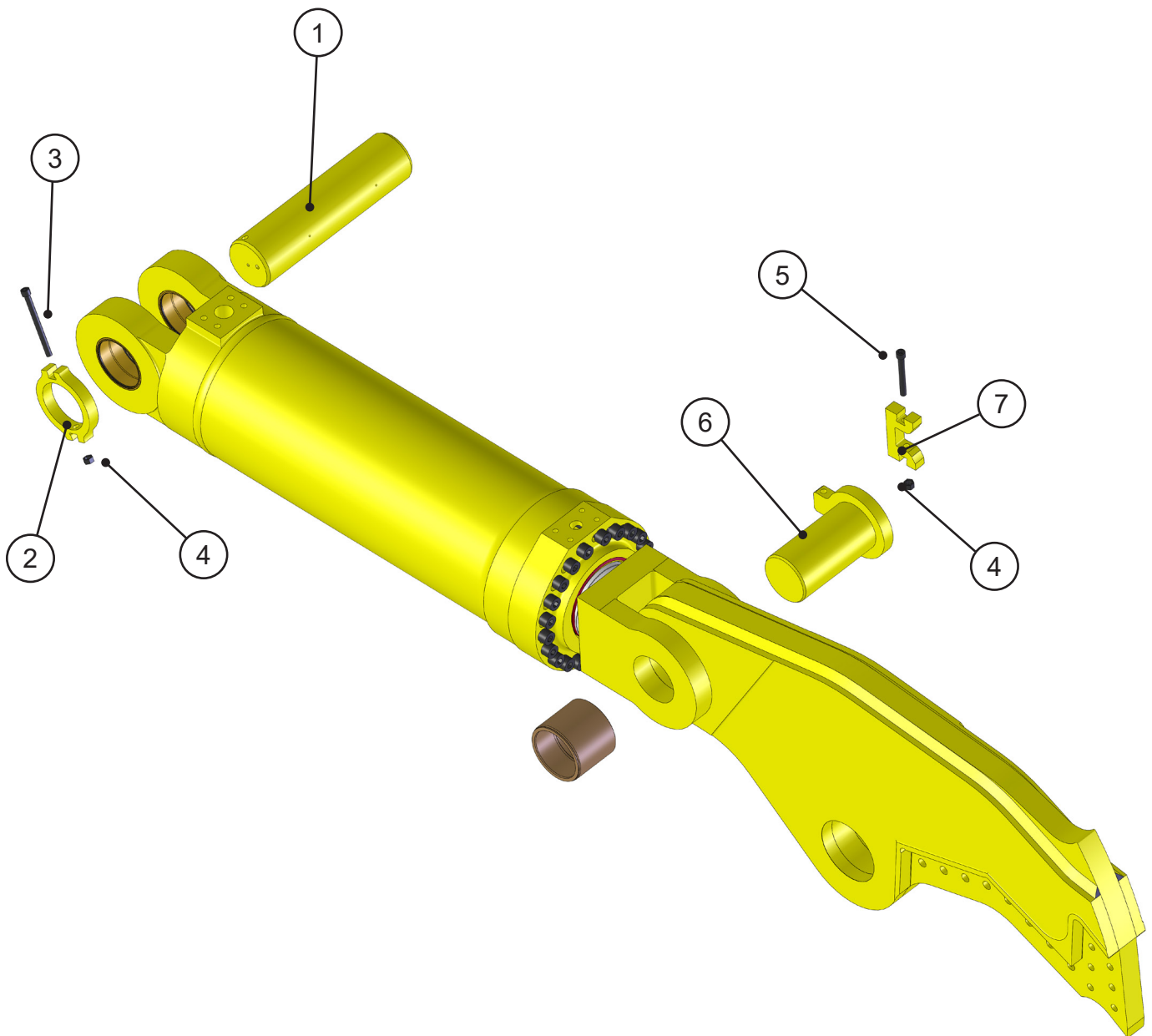

ASSEMBLY CYLINDER PINS

ITEM	QTY	PART NUMBER	DESCRIPTION
1	1	1104086	Mach Pin Rear
2	1	1104088	Mach Pin Keeper
3	1	F0624280	Socket Head Capscrew M24 x 3.00 x 280
4	2	F0824300	Hex Nut M24 x 3.00
5	1	F0624200	Socket Head Capscrew M24 x 3.00 x 200
6	1	1104083	Wldt Pin Front
7	1	1104146	Mach Pin Keeper
8	1	1104047	Mach Bearing Upper Cylinder Connection

ASSEMBLY ACCESS COVERS

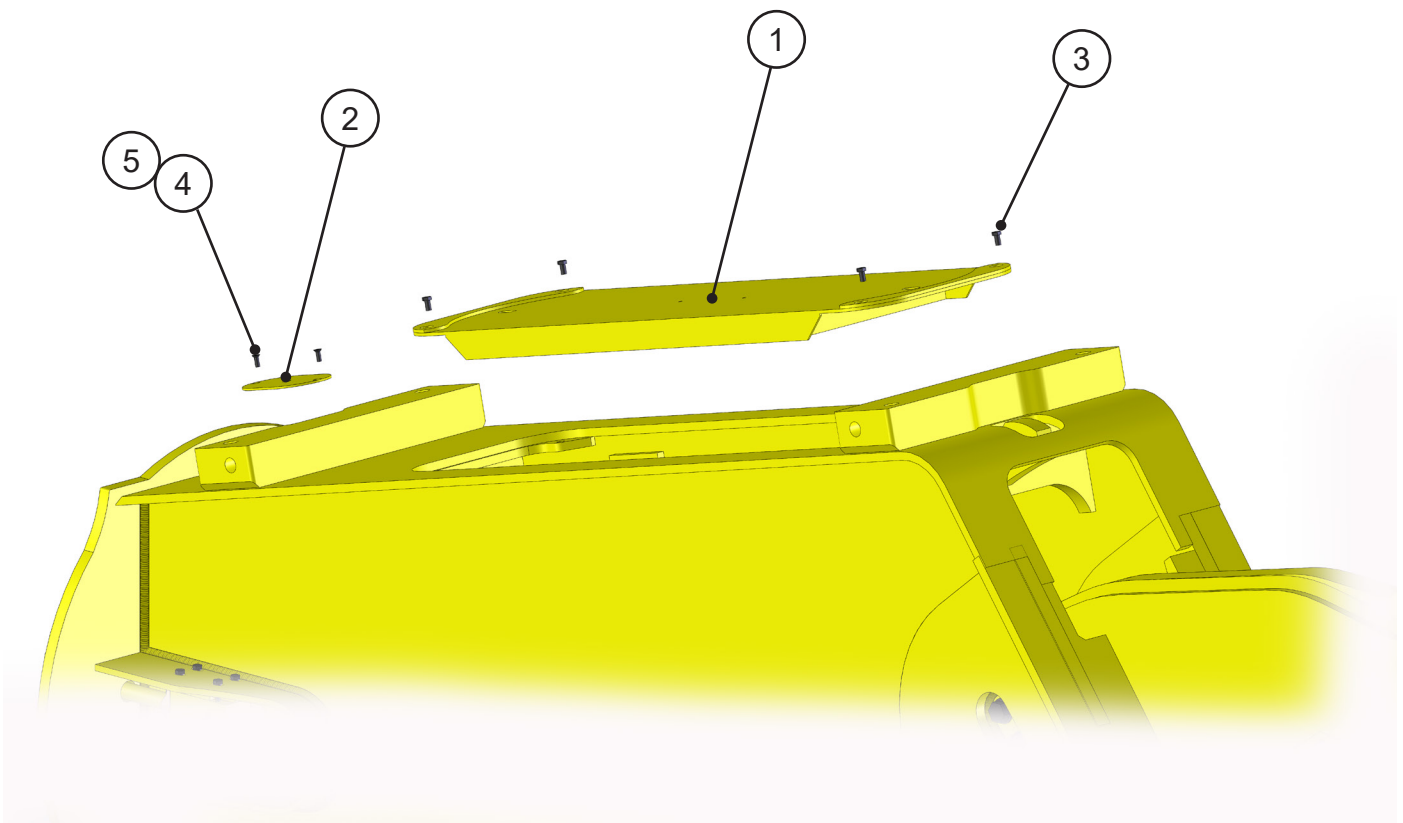

ASSEMBLY ACCESS COVERS

ITEM	QTY	PART NUMBER	DESCRIPTION
1	1	1106067	Wldt Cover
2	1	3101191	Plt Rear Cover
3	4	F0116030	Hex Head Capscrew M16 x 2.0 x 30
4	4	F0112030	Hex Head Capscrew M12 x 1.75 x 30
5	4	F1201224	Flat Washer M12

ASSEMBLY CYLINDER - 6350041

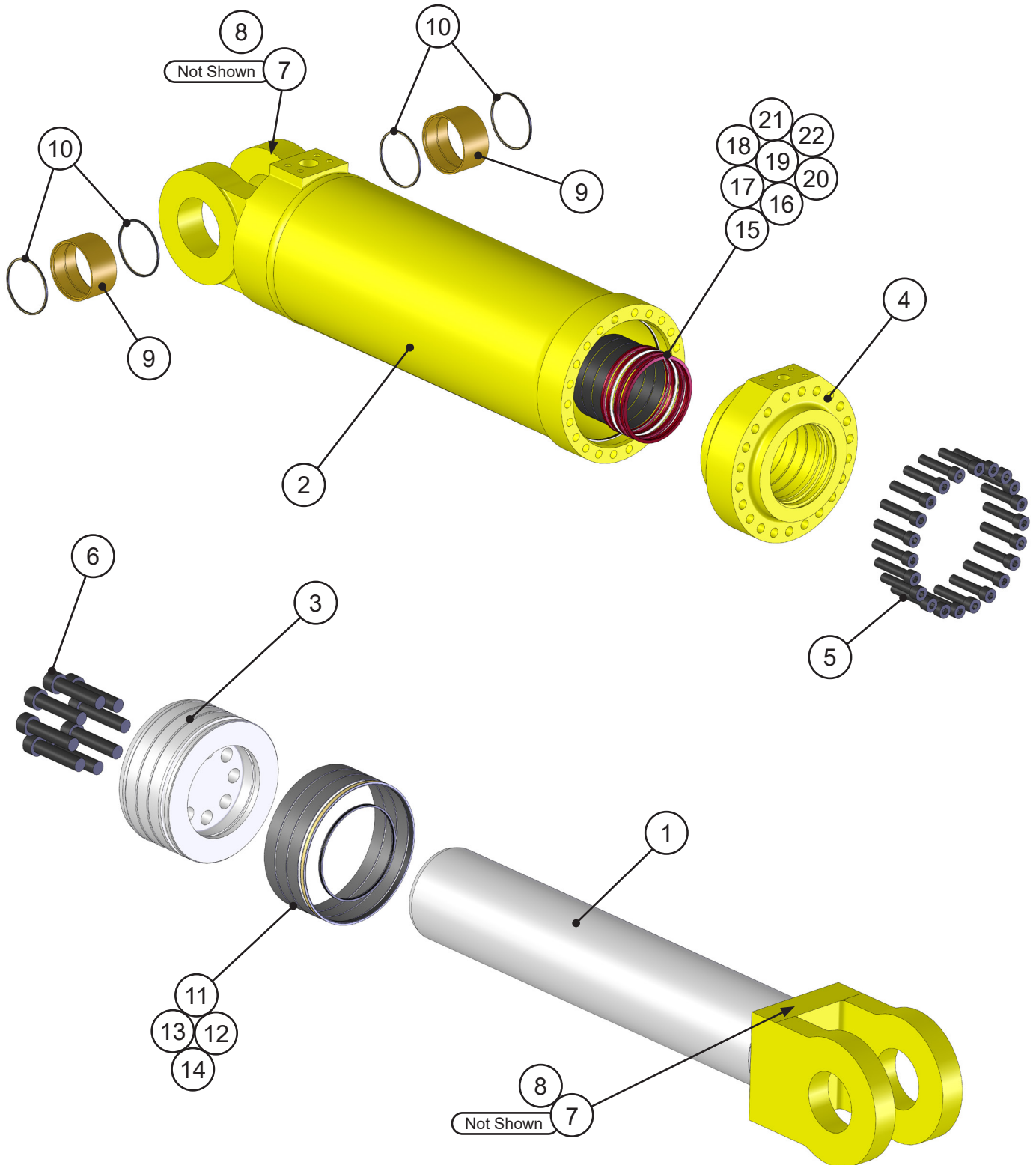

ASSEMBLY CYLINDER - 6350041

ITEM	QTY	PART NUMBER	DESCRIPTION
1	1	6350058	Piston Rod Assembly
2	1	6350059	Butt and Tube Assembly
3	1	6350060	Piston
4	1	6350061	Gland
5	26	6301002	Socket Head Capscrew
6	10	6301003	Socket Head Capscrew
7	2	6301009	Anode
8	4	6301006	Hex Head Capscrew
9	2	6301010	Bushing
10	4	6301023	Canned Wiper
11	3	6301014	Bearing Ring*
12	1	6301013	O-Ring*
13	2	6301017	Back-Up Washer*
14	1	6301019	Capped T-Seal*
15	3	6301015	Rod Bearing Ring*
16	1	6301021	Buffer Seal*
17	1	6301020	U-Cup*
18	2	6301016	Back-Up Washer*
19	1	6301024	Special Wiper*
20	1	6301025	Special Wiper*
21	2	6301022	Kuver Seal*
22		6301018	Back-Up Washer*

* Seals only available in Seal Kit SK00110

PISTON SEAL ARRANGEMENT

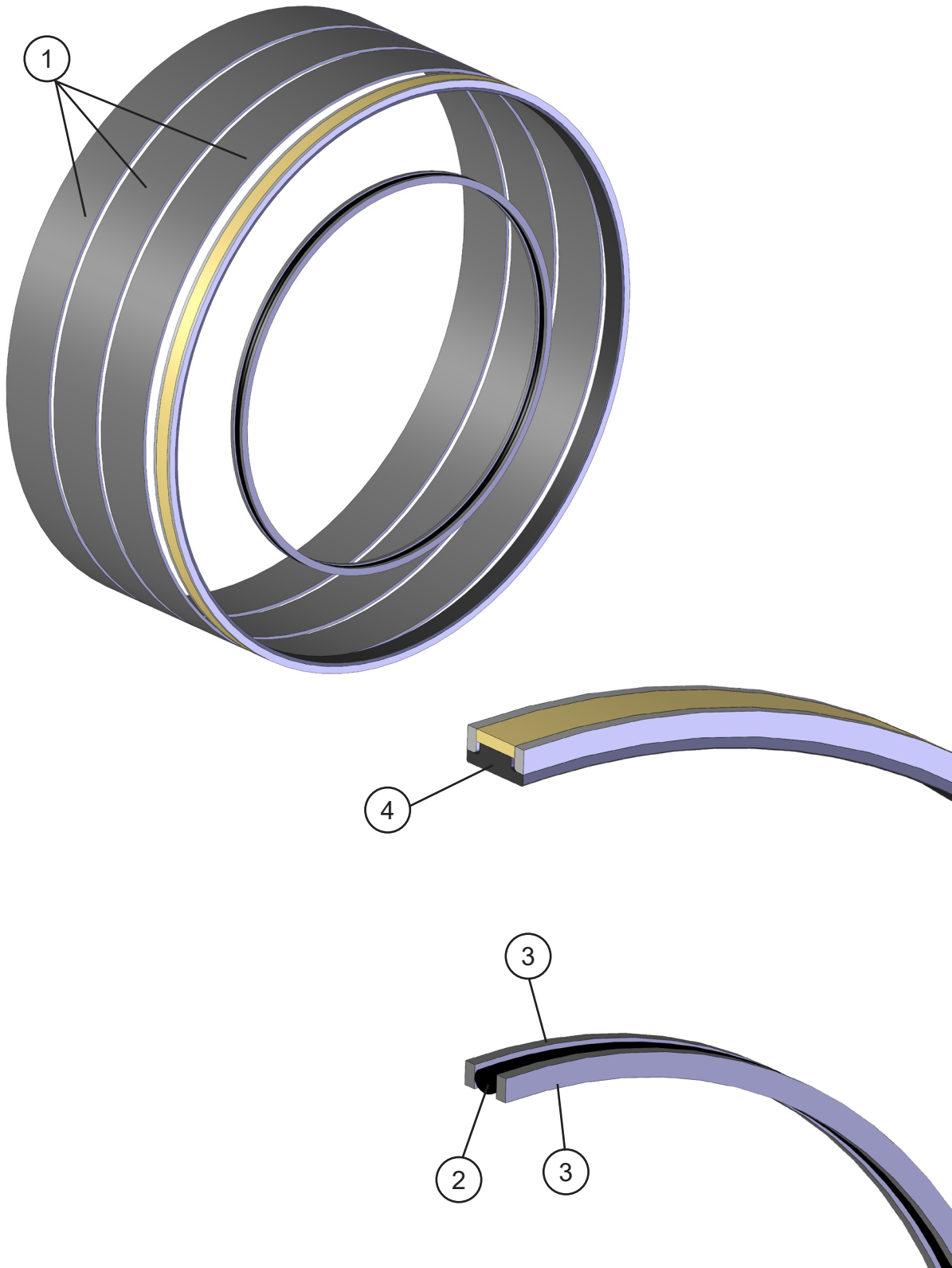

PISTON SEAL ARRANGEMENT

ITEM	QTY	PART NUMBER	DESCRIPTION
1	3	6301014	Bearing Ring*
2	1	6301013	O-Ring*
3	2	6301017	Back-Up Washer*
4	1	6301019	Capped T-Seal*

* Seals only available in Seal Kit SK00110

GLAND SEAL ARRANGEMENT

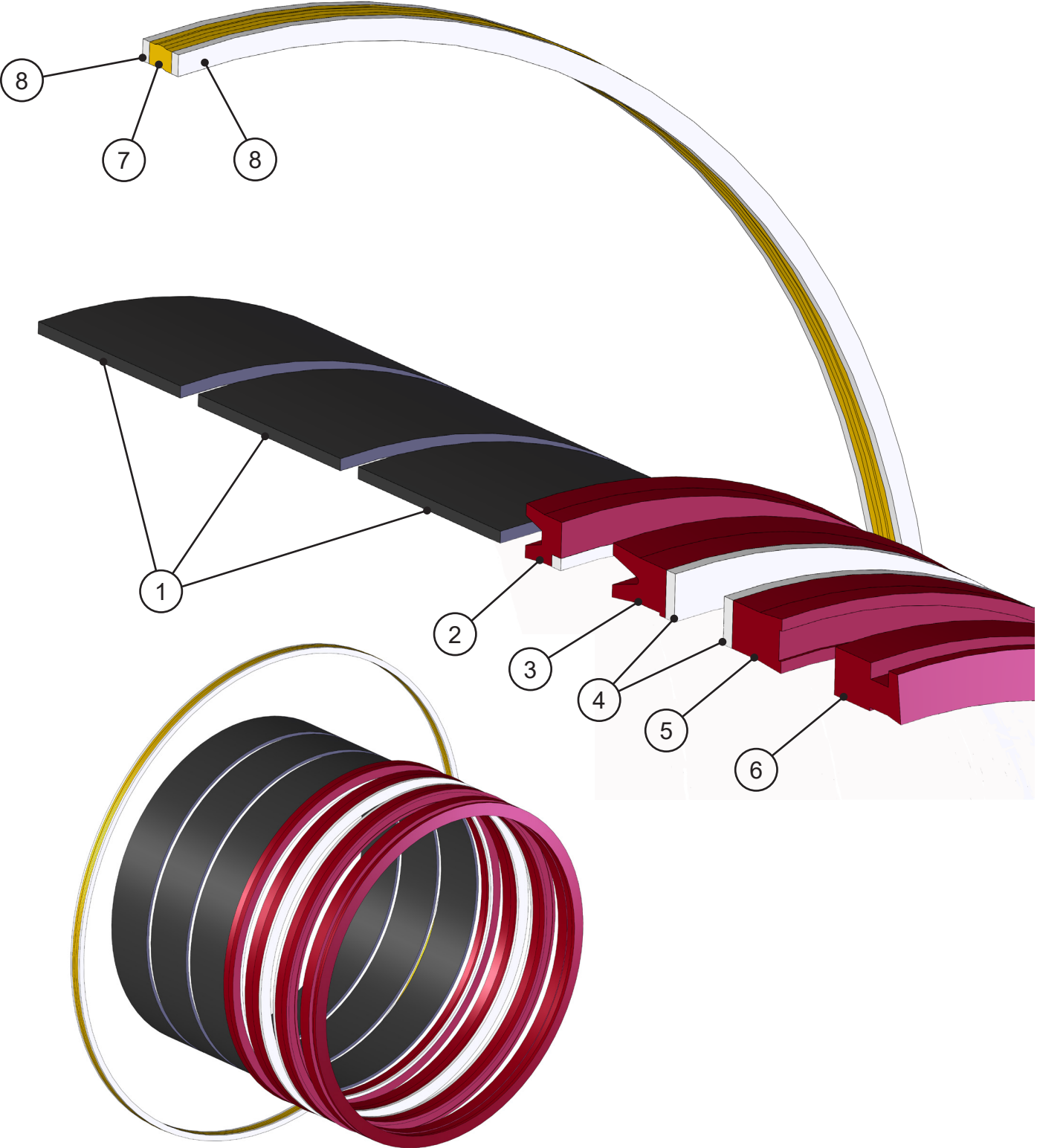

GLAND SEAL ARRANGEMENT

ITEM	QTY	PART NUMBER	DESCRIPTION
1	3	6301015	Rod Bearing Ring
2	1	6301021	Buffer Seal
3	1	6301020	U-Cup
4	2	6301016	Back-Up Washer
5	1	6301024	Special Wiper
6	1	6301025	Special Wiper
7	1	6301022	Kuver Seal
8	2	6301018	Back-Up Washer

* Seals only available in Seal Kit SK00110

SUB-ASSEMBLY CYLINDER - 1201234

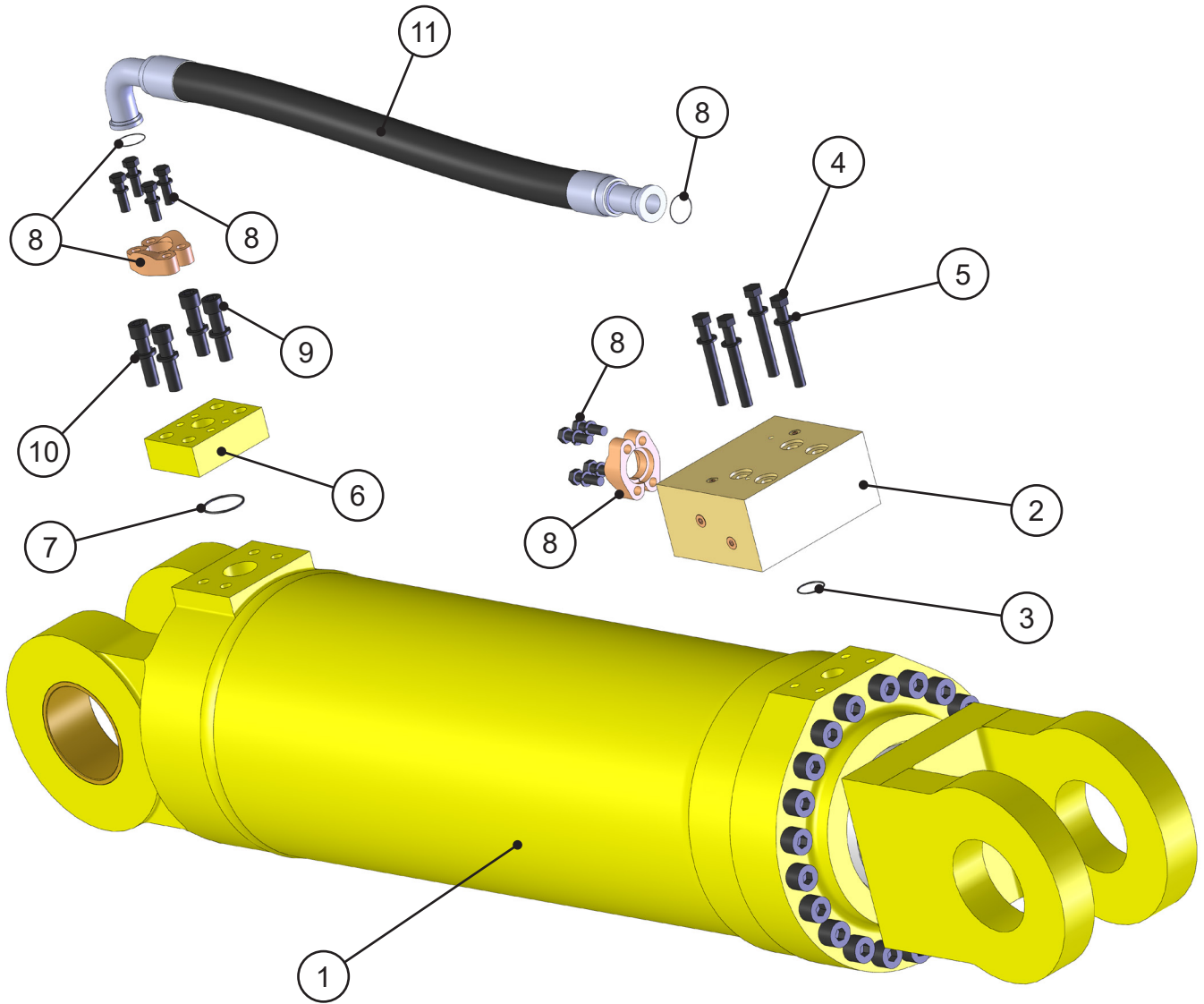

SUB-ASSEMBLY CYLINDER - 1201234

ITEM	QTY	PART NUMBER	DESCRIPTION
1	1	6350041	Assy Cyl B20.0 R13.0 S51.0
2	1	See page 28	Regen Bypass Manifold
3	1	6300922	O-Ring
4	4	F0124190	Hex Head Capscrew M24 x 3 x 190
5	4	F1202444	Flat Washer M24
6	1	1104192	Mach Port Block
7	1	6300745	O-Ring
8	4	2" Split Flange Kit	
	2	H0262200	Split Flange Half 2.00 Code 62
	4	F0120070	Hex Head Capscrew M20 x 2.5 x 70
	4	F1402000	Lock Washer M20
	1	S0190228	O-Ring
9	4	F0711450	Socket Head Capscrew 1 $\frac{1}{8}$ - 7 x 4 $\frac{1}{2}$
10	4	F1500113	Lock Washer 1 $\frac{1}{8}$
11	1	1104204	Hose 32-36WR13-32FLH9062-32FLH62-66.83

REGEN BYPASS MANIFOLD

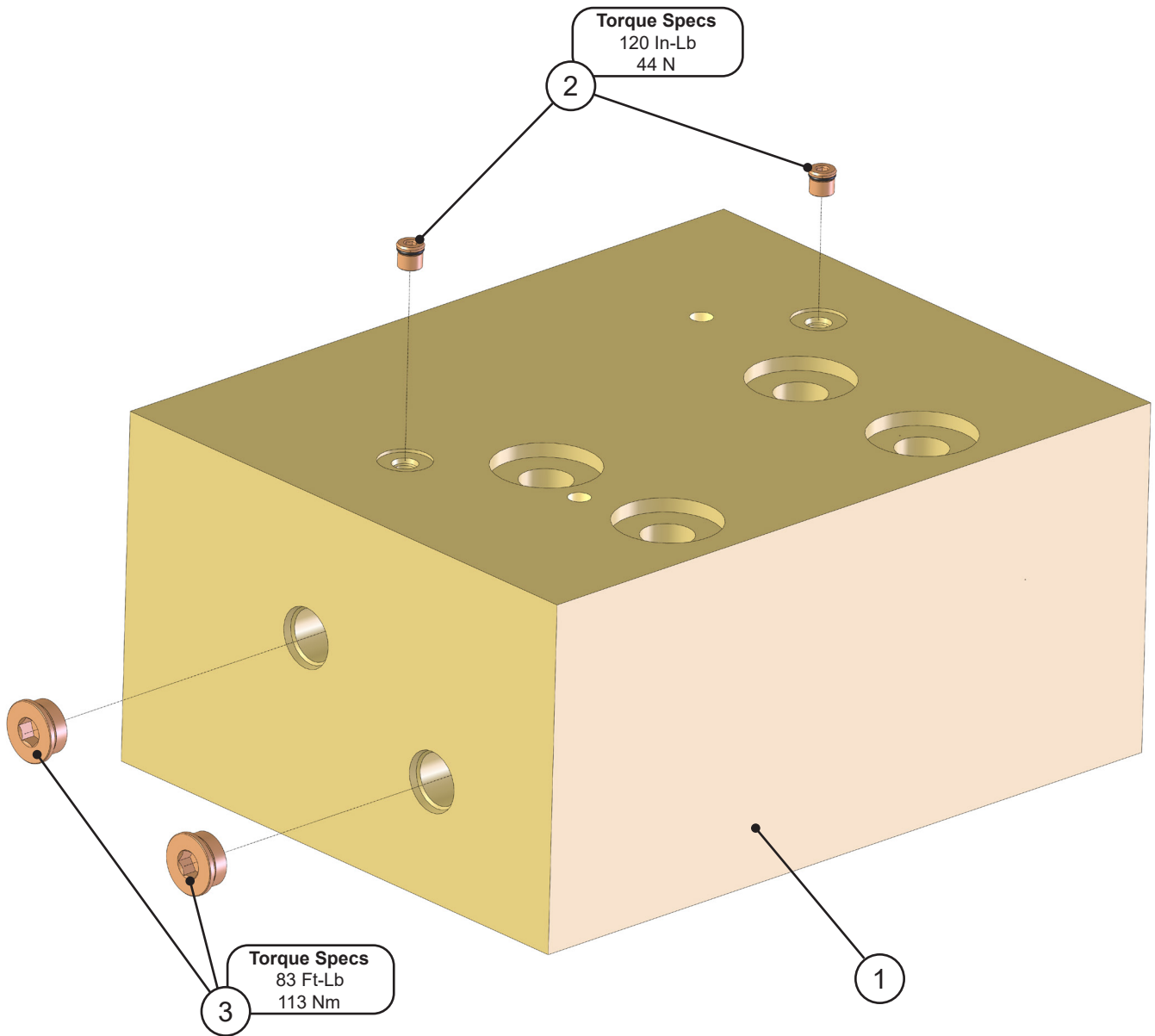

REGEN BYPASS MANIFOLD

ITEM	QTY	PART NUMBER	DESCRIPTION
1	1	6390016	Regen Bypass Manifold
2	2	6310123	Plug 04MO
3	2	6310115	Plug 12MO

ASSEMBLY PORT BLOCK - RIGHT HAND SIDE

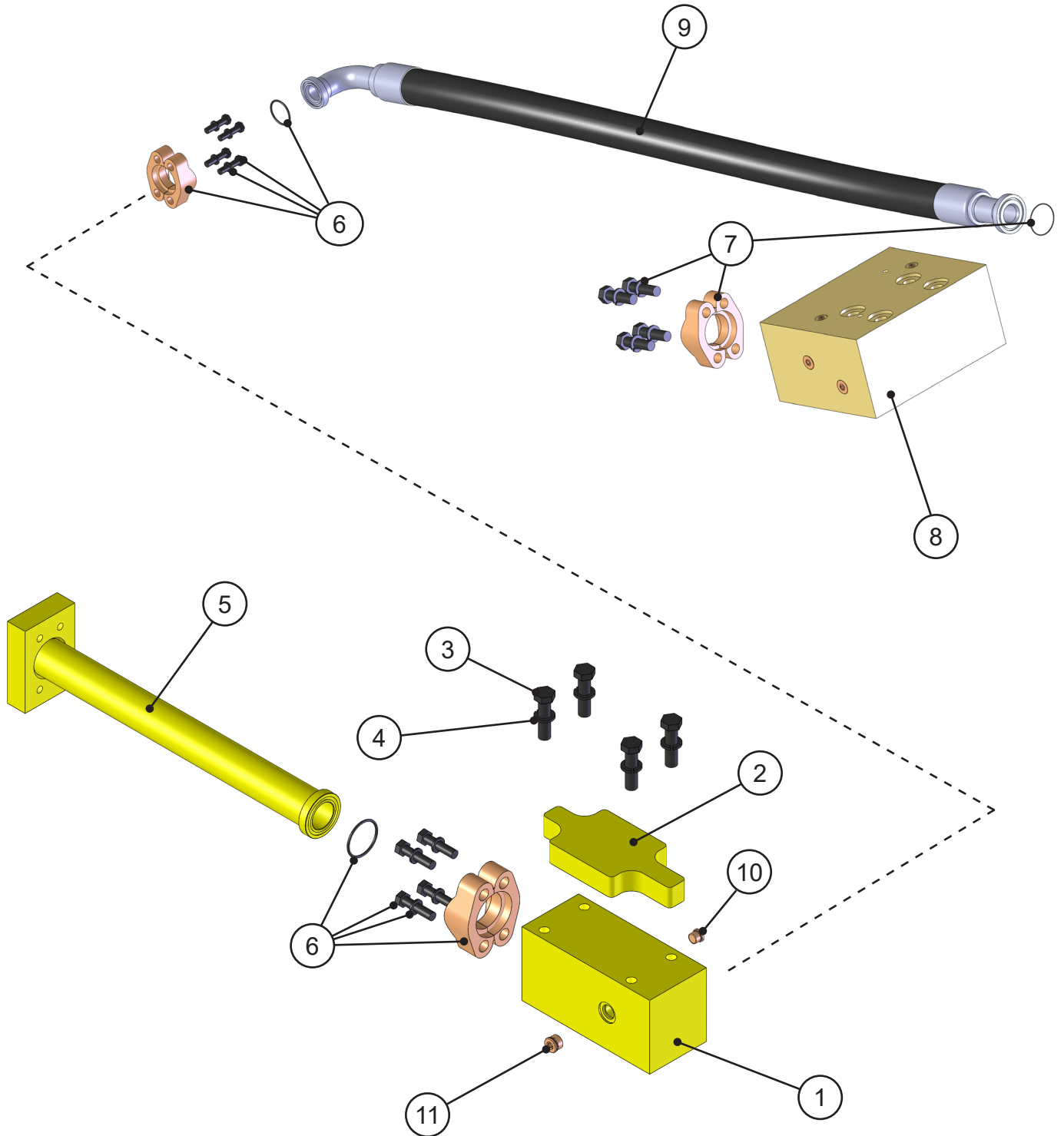

ASSEMBLY PORT BLOCK - RIGHT HAND SIDE

ITEM	QTY	PART NUMBER	DESCRIPTION
1	1	1105226	Mach Port Block
2	1	5507969	Plt Port Block Mount
3	4	F0116070	Hex Head Capscrew M16 x 2.00 x 70
4	4	F1201630	Flat Washer M16
5	1	1105080	Wldt Port Block Tube
6	2	1-1/2" Split Flange Kit	
	2	H0262150	Split Flange Half 1.50 Code 62
	4	F0116060	Hex Head Capscrew M16 x 2.00 x 60
	4	F1401628	Lock Washer M16
	1	S0190225	O-Ring
7	1	2" Split Flange Kit	
	2	H0262200	Split Flange Half 2.00 Code 62
	4	F0120070	Hex Head Capscrew M20 x 2.5 x 70
	4	F1402000	Lock Washer M20
	1	S0190228	O-Ring
8	1	See page 28	Regen Bypass Manifold
9	1	1105340	Hose 24-6WR13-24FLH90-094-32FLH-60.81
10	1	6310065	Plug 06MO
11	1	6310067	Plug 08MO

ASSEMBLY PORT BLOCK - LEFT HAND SIDE

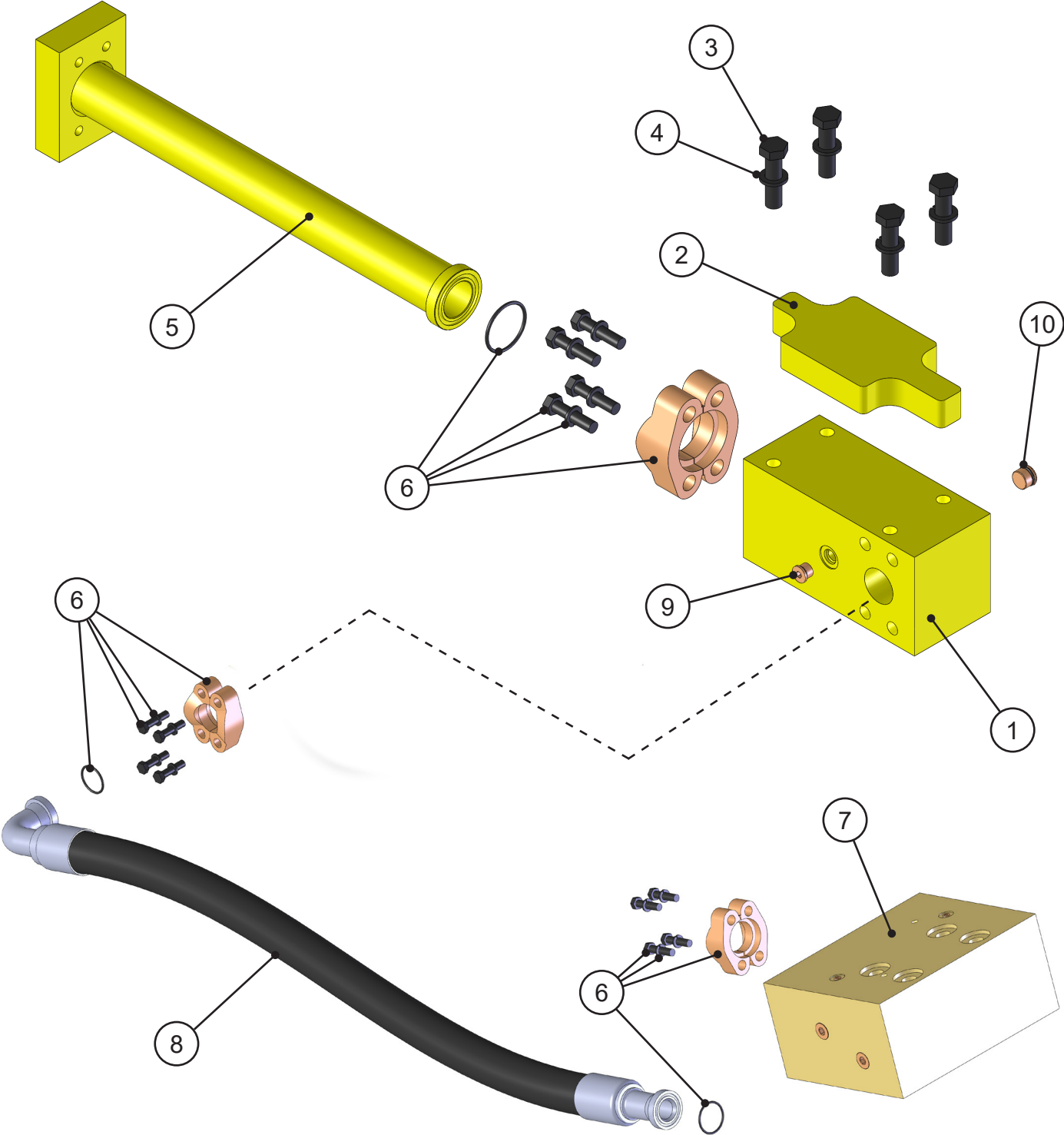

ASSEMBLY PORT BLOCK - LEFT HAND SIDE

ITEM	QTY	PART NUMBER	DESCRIPTION
1	1	1105226	Mach Port Block
2	1	5507969	Plt Port Block Mount
3	4	F0116070	Hex Head Capscrew M16 x 2.00 x 70
4	4	F1201630	Flat Washer M16
5	1	1105080	Wldt Port Block Tube
6	3	1-1/2" Split Flange Kit	
	2	H0262150	Split Flange Half 1.50 Code 62
	4	F0116060	Hex Head Capscrew M16 x 2.00 x 60
	4	F1401628	Lock Washer M16
	1	S0190225	O-Ring
7	1	See page 28	Regen Bypass Manifold
8	1	5300441	Hose 24-6WR13-24FLH90-24FLH-60.81
9	1	6310065	Plug 06MO
10	1	6310067	Plug 08MO

BOLT TORQUE SPECIFICATIONS

Reference the product Thread Treatment Diagrams on page 35 to determine whether to use wet or dry torque values for specific bolts.

Reference Procedures on page 36 for threadlocker or anti-seize application and bolt and bolt hole cleaning.

Prior to torquing, clean all bolt holes, bolts and nuts to remove dirt, grease and oil, and identify bolt type.

Never re-torque bolts that use Loctite. If a bolt becomes loose or damaged after the initial use when Loctite was applied and the bolt was torqued, the bolt must be replaced.

Never break tightened bolts loose with a torque wrench. Doing so may break the torque wrench or take it out of calibration.

Torque wrenches should be calibrated on an annual basis.

When using a torque multiplier with a torque wrench, incorrect settings will be multiplied by the ratio of the torque wrench.

Never use an impact driver on a torque multiplier.

THREAD TREATMENT DIAGRAM

Mobile Shears

Use this diagram to determine what thread treatment, if any, is required for each fastener.

For thread treatment application procedures, see page 36. For prescribed torque values, see page 38

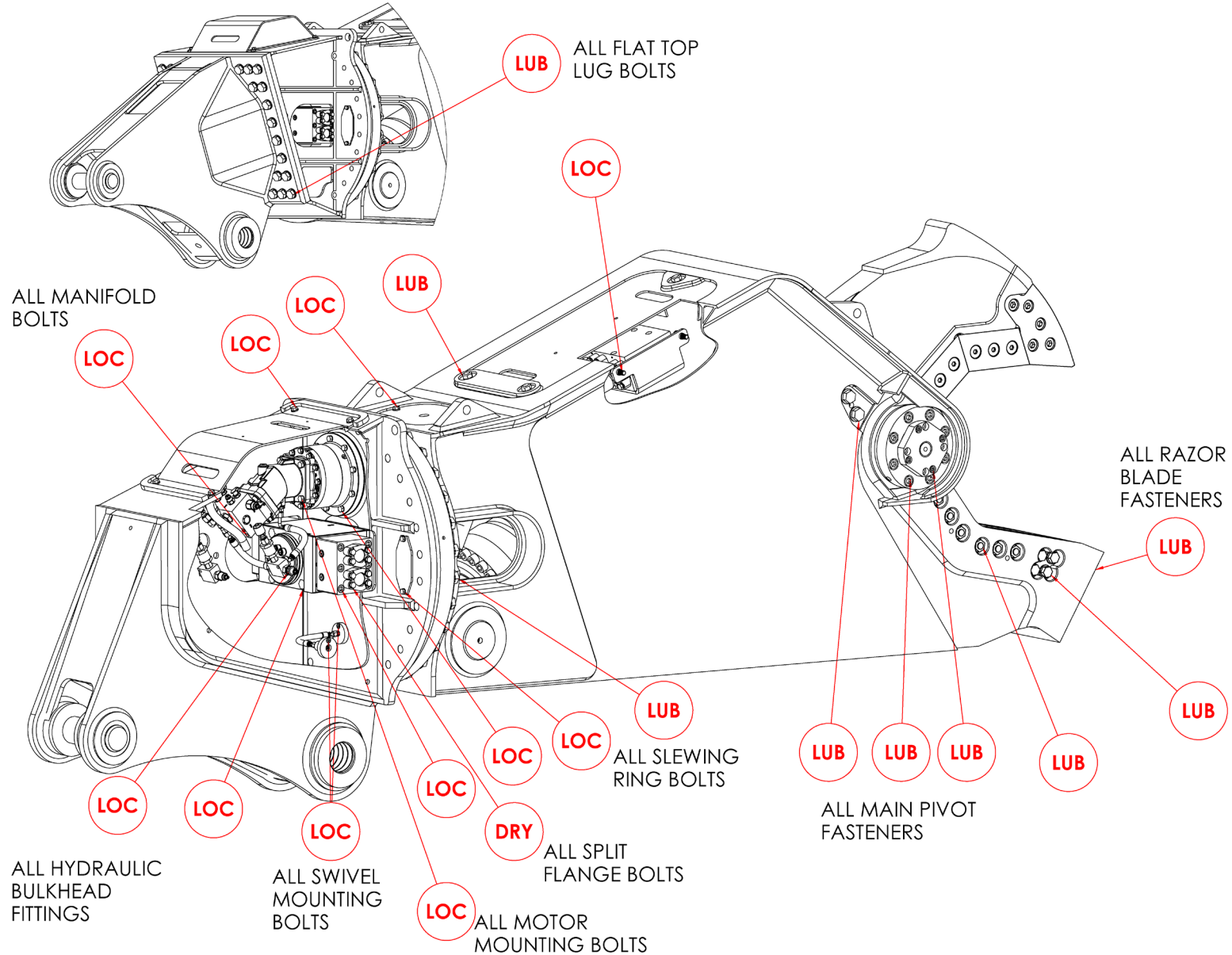

PROCEDURES

Reference the product Thread Treatment Diagrams on page 35 to determine which of the following procedures is required.

Cleaning

To ensure proper performance of thread treatment and accurate torque values, clean and degrease **all internal and external threads** prior to application of threadlocker, anti-seize or primer and before installation of hardware.

- Ensure both internal and external threads are free of dirt or debris.
- Use brake cleaner or similar cleaning solvent on all threads to remove any grease or oil.
- Allow threads to dry.

NOTICE

Failure to properly clean threads will cause threadlocker, primer, and/or anti-seize to not properly cure!

LOC

Threadlocker

For bolted connections requiring threadlocker, use **Loctite 263** or equivalent applied using the following procedure:

- Clean and degrease all threads.
- For thru holes or nuts, apply threadlocker to bolt threads.
- For blind holes, apply stripe of threadlocker along the length of the hole (applying to the bolt can cause escaping air to remove threadlocker as the bolt is inserted).
- Torque bolt to specified **Wet Torque Value**, see page 38.

For threaded hydraulic fitting connections, use **Loctite 5452** or equivalent thread sealant in conjunction with **Loctite 7471** primer using the following procedure:

- Clean and degrease all threads.
- Apply Loctite 7471 primer to both external and internal threads and allow to dry.
- Apply threadlocker to 360 degrees of the threads on the male fitting, ensuring adequate coverage.
- Assemble fitting per directions in operator's manual.
- For O-ring boss and flat face O-ring connections, torque fittings to values specified on page 39.

Threadlocker

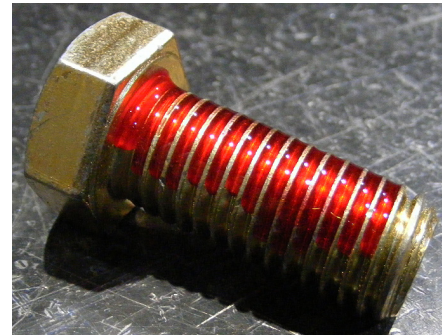

Blind Hole

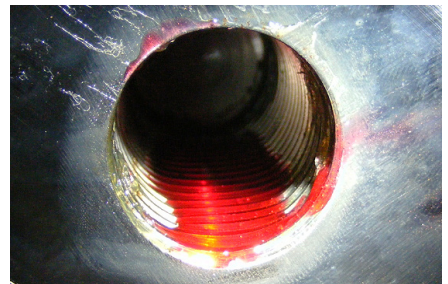

Hydraulic Fitting



PROCEDURES

LUB

Anti-Seize

For bolted connections requiring anti-seize lubrication, use **Loctite LB8008** or equivalent using the following procedure:

- Clean and degrease all threads.
- Apply thin coat of anti-seize to internal and external threads and under bolt head and/or nut, ensuring complete coverage.
- Torque bolt to specified **Wet Torque Value**, see page 38.

Anti-Seize









DRY

No Thread Treatment

- Clean and degrease all threads.
- Torque bolt to specified **Dry Torque Value**, see page 38.

BOLT TORQUE SPECIFICATIONS

Dry Torque Values					
		Hex/Socket Head		Flat Head	
					
Fastener Grade	Size x Pitch	Nm	Ft-lb	Nm	Ft-lb
CL 10.9	M8 x 1.25	35	26	27	20
	M10 x 1.50	71	53	58	42
	M12 x 1.75	124	92	101	73
	M14 x 1.50	200	148	163	118
	M14 x 2.00	200	148	163	118
	M16 x 2.00	311	230	254	184
	M20 x 1.50	610	450	498	360
	M20 x 2.50	608	449	497	359
	M24 x 3.00	1054	778	861	622
	M27 x 3.00	1543	1138	1260	910
	M30 x 3.50	2095	1545	1712	1236
	M36 x 4.00	3659	2699	2991	2159
8	1/4-20	14	11	11	8
	5/16-18	32	24	26	19
	3/8-16	59	44	48	35
	7/16-14	94	70	77	56
	1/2-13	143	106	116	84
	1/2-20	162	120	133	96
	5/8-11	287	212	234	169
	3/4-10	509	376	415	300
	7/8-9	821	606	670	484
	1.00-8	1232	909	1007	727
	1.00-14	1383	1020	1130	816
	1.25-7	2463	1817	2013	1453
L9	1.50-6	4287	3162	3504	2529

Wet Torque Values					
		Hex/Socket Head		Flat Head	
					
Fastener Grade	Size x Pitch	Nm	Ft-lb	Nm	Ft-lb
CL 10.9	M8 x 1.25	29	22	23	17
	M10 x 1.50	61	45	49	36
	M12 x 1.75	105	78	85	62
	M14 x 1.50	150	111	121	88
	M14 x 2.00	170	126	138	100
	M16 x 2.00	265	196	216	156
	M20 x 1.50	456	337	372	269
	M20 x 2.50	517	382	422	305
	M24 x 3.00	894	660	731	528
	M27 x 3.00	1312	968	1072	774
	M30 x 3.50	1779	1312	1453	1049
	M36 x 4.00	3110	2294	2542	1835
8	1/4-20	13	10	11	8
	5/16-18	27	20	22	16
	3/8-16	50	37	40	29
	7/16-14	80	59	65	47
	1/2-13	122	90	99	72
	1/2-20	138	102	112	81
	5/8-11	244	180	199	144
	3/4-10	433	320	354	256
	7/8-9	698	515	570	412
	1.00-8	1046	772	854	617
	1.00-14	1175	867	960	693
	1.25-7	2095	1545	1712	1236
L9	1.50-6	3644	2688	2979	2150

O-RING BOSS & FLAT FACE O-RING TORQUE SPECIFICATIONS

O-Ring Boss Torque Values		
Size Dash	Nm	Ft-lb
-4	22	16
-5	27	20
-6	36	26
-8	83	60
-10	110	80
-12	187	135
-14	249	180
-16	304	220
-20	387	280
-24	498	360

Flat Face O-Ring Torque Values		
Size Dash	Nm	Ft-lb
-4	18	13
-6	30	22
-8	60	44
-10	85	62
-12	121	88
-14	121	88
-16	160	116
-20	213	154
-24	274	198

BOLT DRIVE SPECIFICATIONS

Thread Size x Pitch	Hex Head	Socket Head	Flat Head
			
Wrench/Drive Size			
M8 x 1.25	13mm	6mm	5mm
M10 x 1.50	17mm	8mm	6mm
M12 x 1.75	19mm	10mm	8mm
M14 x 1.50	22mm	12mm	10mm
M14 x 2.00	22mm	12mm	10mm
M16 x 2.00	24mm	14mm	10mm
M20 x 1.50	30mm	17mm	12mm
M20 x 2.50	30mm	17mm	12mm
M24 x 3.00	36mm	19mm	14mm
M27 x 3.00	41mm	19mm	-
M30 x 3.50	46mm	22mm	-
M36 x 4.00	55mm	27mm	-
1/4-20	7/16"	3/16"	5/32"
5/16-18	1/2"	1/4"	3/16"
3/8-16	9/16"	5/16"	7/32"
7/16-14	5/8"	3/8"	1/4"
1/2-13	3/4"	3/8"	5/16"
1/2-20	3/4"	3/8"	5/16"
5/8-11	15/16"	1/2"	3/8"
3/4-10	1-1/8"	5/8"	1/2"
7/8-9	1-5/16"	3/4"	9/16"
1.00-8	1-1/2"	3/4"	5/8"
1.00-14	1-1/2"	3/4"	5/8"
1.25-7	1-7/8"	7/8"	7/8"
1.50-6	2-1/4"	1"	1"

WARRANTY

Claim Procedure

Notify the Genesis Service Department of the potential warranty claim prior to making the repair. Digital pictures are very helpful for diagnosing problems and recommending repairs.

Contact the Genesis Service Department before making alterations, changes or repairs to any component that is going to be considered for warranty. Not doing so will void all Genesis warranty consideration.

The Genesis Service Department will issue an authorization number to track the repair costs, outgoing parts, and/or defective parts returning to the factory.

Replacement parts must be ordered using a purchase order number. Shipping is standard ground. Overnight shipping is available by request, and Genesis will not cover the shipping charge.

When the repair is complete, submit an invoice to the Genesis Service Department within 30 days. Include itemized internal labor reporting, parts lists and invoices for outside contractors. Reference the authorization number on all invoices.

When returning parts for warranty consideration, include a copy of any related Genesis paperwork along with any other necessary documentation to ensure proper processing and credit. The Genesis Service Department will provide the necessary forms.

Your account will be credited when the warranty claim is accepted.

Blade Warranty

Standard warranty on blades will only be considered on the first edge, and wear on the edge must be 1/8" radius or less. Genesis does not warranty cutting blades that are cracked or broken from top to bottom (perpendicular to the long edge of the blade). Genesis also does not cover fasteners, the labor to replace wear components or collateral damage, such as blade seats, from broken blades, the piercing blade tang or adjustment plates.

Please direct any questions to the Genesis Service Department: 715-395-5252

PARTS ORDER POLICY AND PROCEDURE

Parts Orders Should Include

- Purchase order number
- Model and serial number of attachment
- Part number and quantity needed
- Shipping and billing address
- Method of shipment or required delivery date

Placing Orders

Orders may be placed by phone or e-mail. To e-mail an order, use the form on the following page or your purchase order form. Contact information is located at the front of this manual.

Part Numbers

Part numbers are listed in a separate Parts Manual or, if included, the Parts section of this manual. Contact the Genesis Parts Department with questions regarding part numbers, availability and pricing.

Shipping

All orders will be shipped best way surface unless an alternate shipping method is requested. Shipping charges are not included in the purchase price of parts.

Invoices

All invoices are due upon receipt. Any accounts with invoices open beyond 60 days are subject to review and may be placed on C.O.D. status without further notice.

Returns

Many unused Genesis parts may be returned with proper documentation. Return shipping is the responsibility of the purchaser. Credit will be issued upon return, less a 25% restocking fee. Documentation is required for credit of returned parts. Contact the Genesis Service Department at 715-395-5252 for an RGA (Return Goods Authorization) number and form. An RGA must accompany every return. Items shipped without an RGA may be returned to sender.

Warranty Returns

All parts returned to Genesis for warranty consideration must be returned with a completed RGA (Return Goods Authorization) provided by the Genesis Service Department. The form needs to be completed in its entirety, including any additional information requested by the Service Department. Return shipping is the responsibility of the sender and will be credited upon claim approval. A determination to accept or deny the claim will be made based upon the information available to Genesis. Warranty on purchased parts other than wear components is 6 months. Genesis does not cover labor costs to replace purchased parts replaced under warranty. There is no warranty period on wear parts or components.

INDEX

- 1-1/2" Split Flange Kit 31, 33
- 2" Split Flange Kit 27, 31
- 1104010 Mach Blade 11, 13
- 1104011 Mach Blade Tip RH 13
- 1104012 Mach Blade Tip LH 13
- 1104013 Mach Blade Guide 11
- 1104047 Mach Bearing Upper Cylinder Connection 17
- 1104048 Mach Thrust Washer 7, 9
- 1104049 Shim Set Thrust Washer 7, 9
- 1104050 Mach Main Shaft 9
- 1104052 Mach Bearing RH 7
- 1104053 Mach Bearing LH 9
- 1104071 Blade Shim Set 11
- 1104072 Guide Shim Set, Blade Side 11
- 1104073 Mach Blade Razor 11
- 1104075 Mach End Cap 7, 9
- 1104078 Mach Tie Rod 7
- 1104081 Mach Tie Rod Nut 7, 9
- 1104083 Wldt Pin Front 17
- 1104086 Mach Pin Rear 17
- 1104088 Mach Pin Keeper 17
- 1104143 Mach Bolt Socket Head Capscrew 1¼ - 7 x 6½ 13
- 1104146 Mach Pin Keeper 17
- 1104192 Mach Port Block 27
- 1104195 Mach Adjustment Plt Primary 11
- 1104196 Mach Adjustment Plt Secondary 11
- 1104197 Mach Adjustment Plt Guide 11
- 1104204 Hose 32-36WR13-32FLH9062-32FLH62-66.83 27
- 1104207 Mach Auto Guide 15
- 1104209 Mach Auto Guide Adjustment Plate 15
- 1104453 Shim Set, Auto Guide 15
- 1105077 Wtmg Stick 5
- 1105080 Wldt Port Block Tube 31, 33
- 1105158 Mach Adjustment Plt GB 11
- 1105226 Mach Port Block 31, 33
- 1105325 Wtmg Upper 5
- 1105340 Hose 24-6WR13-24FLH90-094-32FLH-60.81 31
- 1106067 Wldt Cover 19
- 3101191 Plt Rear Cover 19
- 5300441 Hose 24-6WR13-24FLH90-24FLH-60.81 33
- 5507969 Plt Port Block Mount 31, 33
- 6200002 Grease Fitting 7, 9, 15
- 6200077 Shackle Double Swing 5
- 6300134 Dowel Pin 11
- 6300745 O-Ring 27
- 6300922 O-Ring 27
- 6301002 Socket Head Capscrew 21
- 6301003 Socket Head Capscrew 21
- 6301006 Hex Head Capscrew 21
- 6301009 Anode 21
- 6301010 Bushing 21
- 6301013 O-Ring 21, 23
- 6301014 Bearing Ring 21, 23
- 6301015 Rod Bearing Ring 21, 25
- 6301016 Back-Up Washer 21, 25
- 6301017 Back-Up Washer 21, 23
- 6301018 Back-Up Washer 21, 25
- 6301019 Capped T-Seal 21, 23
- 6301020 U-Cup 21, 25
- 6301021 Buffer Seal 21, 25
- 6301022 Kuver Seal 21, 25
- 6301023 Canned Wiper 21
- 6301024 Special Wiper 21, 25
- 6301025 Special Wiper 21, 25
- 6310065 Plug 06MO 31, 33
- 6310067 Plug 08MO 31, 33
- 6310115 Plug 12MO 29
- 6310123 Plug 04MO 29
- 6350041 Assy Cyl B20.0 R13.0 S51.0 27
- 6350058 Piston Rod Assembly 21
- 6350059 Butt and Tube Assembly 21
- 6350060 Piston 21
- 6350061 Gland 21
- 6390016 Regen Bypass Manifold 29
- Assembly Access Covers 5, 18, 19
- Assembly Auto Guide 5, 14, 15
- Assembly Cylinder 5
- Assembly Cylinder - 6350041 20, 21
- Assembly Cylinder Pins 5, 16, 17
- Assembly Lower Blades 5
- Assembly Lower Shear Blades 10, 11
- Assembly Pivot Group - Left Hand Side 5, 8, 9
- Assembly Pivot Group - Right Hand Side 5, 6, 7
- Assembly Port Block - Left Hand Side 5, 32, 33
- Assembly Port Block - Right Hand Side 5, 30, 31
- Assembly Upper Blades 5
- Assembly Upper Shear Blades 12, 13
- Bolt Drive Specifications 40
- Bolt Torque Specifications 34, 38
- Contact Information 2, 46
- F0112030 Hex Head Capscrew M12 x 1.75 x 30 19
- F0116030 Hex Head Capscrew M16 x 2.0 x 30 19
- F0116060 Hex Head Capscrew M16 x 2.00 x 60 31, 33
- F0116070 Hex Head Capscrew M16 x 2.00 x 70 31, 33
- F0120070 Hex Head Capscrew M20 x 2.5 x 70 27, 31
- F0124190 Hex Head Capscrew M24 x 3 x 190 27
- F0210300 Hex Head Capscrew 1 - 8 x 3 11
- F0215600 Hex Head Capscrew 1½ - 6 x 6 11
- F0215800 Hex Head Capscrew 1½ - 6 x 8 15
- F0412035 Flat Head Capscrew M12 x 1.75 x 35 7, 9
- F0515700 Flat Head Capscrew 1½ - 6 x 7 11
- F0515800 Flat Head Capscrew 1½ - 6 x 8 13
- F0515900 Flat Head Capscrew 1½ - 6 x 9 13
- F0612050 Socket Head Capscrew M12 x 1.75 x 50 7, 9
- F0616050 Socket Head Capscrew M16 x 2.00 x 50 7, 9
- F0624080 Socket Head Capscrew M24 x 3.00 x 80 7, 9
- F0624200 Socket Head Capscrew M24 x 3.00 x 200 17

INDEX

F0624280 Socket Head Capscrew M24 x 3.00 x 280 17
F0711450 Socket Head Capscrew 1 $\frac{1}{8}$ - 7 x 4 $\frac{1}{2}$ 27
F0824300 Hex Nut M24 x 3.00 17
F0915006 Hex Nut 1 $\frac{1}{2}$ - 6 11, 13
F1201224 Flat Washer M12 7, 9, 19
F1201630 Flat Washer M16 7, 9, 31, 33
F1202444 Flat Washer M24 27
F1300100 Flat Washer 1" 11
F1300150 Flat Washer 1 $\frac{1}{2}$ 11, 13, 15
F1401628 Lock Washer M16 31, 33
F1402000 Lock Washer M20 27, 31
F1500113 Lock Washer 1 $\frac{1}{8}$ 27
F2510100 Set Screw Socket Head 1 - 8 x 1 11
General Arrangement 4, 5
Gland Seal Arrangement 24, 25
H0262150 Split Flange Half 1.50 Code 62 31, 33
H0262200 Split Flange Half 2.00 Code 62 27, 31
O-Ring Boss & Flat Face O-Ring Torque Specifications 39
Parts Order Form 43
Parts Order Policy and Procedure 42
Piston Seal Arrangement 22, 23
Procedures 36, 37
Regen Bypass Manifold 27, 28, 29, 31, 33
S0190225 O-Ring 31, 33
S0190228 O-Ring 27, 31
S0190254 O-Ring 7, 9
Seal Kit SK00110 21, 23, 25
Sub-Assembly Cylinder - 1201234 26, 27
Table of Contents 3
Thread Treatment Diagram 35
Warranty 41



GENESIS®

The Promise of Performance.

CONTACT INFORMATION

Genesis Attachments

1000 Genesis Drive
Superior, WI 54880 USA

Toll Free: 888-SHEAR-IT
(888-743-2748)

Phone: 715.395.5252

E-mail:
info@genesisattachments.com

Europe/Africa/Middle East Genesis GmbH

Teramostrasse 23
87700 Memmingen, Germany

Phone: +49 83 31 9 25 98 0
Fax: +49 83 31 9 25 98 80
genesis-europe.com

E-mail:
info@genesis-europe.com

Asia Pacific Representative Office

24 Upper Serangoon View #12-28
Singapore 534205

Phone: +65 9673 9730

E-mail:
tchoo@genesisattachments.com

Central America & Colombia

Cra 13A #89-38 / Ofi 613
Bogota, Colombia

Phone: +57 1 610 8160 / 795 8747

E-mail:
contact@themsagroup.com

View and download all manuals: genesisattachments.com/manuals
Patents: genesisattachments.com/products/patents