

GENESIS[®]

The Promise of Performance.

LXP[®] 200 - 500 Logix Processor

SAFETY, OPERATOR'S & PARTS MANUAL



CONTACT INFORMATION

Genesis Attachments

1000 Genesis Drive
Superior, WI 54880 USA

Toll Free: 888-SHEAR-IT
(888-743-2748)

Phone: 715.395.5252

E-mail:
info@genesisattachments.com

Europe/Africa/Middle East Genesis GmbH

Teramostrasse 23
87700 Memmingen, Germany

Phone: +49 83 31 9 25 98 0
Fax: +49 83 31 9 25 98 80
genesis-europe.com

E-mail:
info@genesis-europe.com

Asia Pacific Representative Office

24 Upper Serangoon View #12-28
Singapore 534205

Phone: +65 9673 9730

E-mail:
tchoo@genesisattachments.com

Central America & Colombia

Cra 13A #89-38 / Ofi 613
Bogota, Colombia

Phone: +57 1 610 8160 / 795 8747

E-mail:
contact@themsagroup.com

View and download all manuals: [genesisattachments.com/manuals](https://www.genesisattachments.com/manuals)
Patents: [genesisattachments.com/products/patents](https://www.genesisattachments.com/products/patents)

PREFACE

To ensure years of safe, dependable service, only trained and authorized persons should operate and service your Genesis attachment. It is the responsibility of the product's owner to ensure the operator is trained in the safe operation of the product and has available this manual for review. It is the responsibility of the operator and maintenance personnel to read, fully understand and follow all operational and safety-related instructions in this manual. The attachment should not be operated until you have read and fully understand these instructions. Always use good safety practices to protect yourself and those around you.

Important

This operator's manual must accompany the attachment at all times and be readily available to the operator.

Manual Replacement

Should this manual become damaged or lost or if additional copies are required, immediately contact any authorized Genesis dealer or the Genesis Service Department at 888-743-2748 or 715-395-5252 for a replacement.

Registration Form

The Warranty Registration Form must be filled out by the dealer or customer and returned to Genesis indicating the date the attachment went into service.

Possible Variations

Genesis cannot anticipate every possible circumstance that might involve a potential hazard as the owner's requirements and equipment may vary. Therefore, the warnings in this publication and on the product may not be all-inclusive, and you must satisfy yourself that the procedure, application, work method or operating technique is safe for you and others before operating.

Public Notice

Genesis reserves the right to make changes and improvements to its products and technical literature at any time without public notice or obligation. Genesis also reserves the right to discontinue manufacturing any product at its discretion at any time.

Warranty

All work or repairs to be considered for warranty reimbursement must be pre-authorized by the Genesis Service Department. Any alterations, modifications or repairs performed before authorization by the Genesis Service Department will render all warranty reimbursement consideration null and void without exception. See page 63 for Warranty Claim Procedures.

Improper operation or improperly performed maintenance may render any warranty null and void.

TABLE OF CONTENTS

CONTACT INFORMATION	2
PREFACE	3
Important	3
Manual Replacement	3
Registration Form	3
Possible Variations	3
Public Notice	3
Warranty	3
SAFETY STATEMENTS	8
OPERATIONAL SAFETY	9
Read Manual Before Operating or Maintaining the Attachment	9
Personal Protection	9
Know Your Equipment	9
Before Operating	9
Check the Equipment	10
Stability	10
Know the Work Area	11
Starting Procedure	11
Place the Load Safely	11
Safely Operate Equipment	12
Transporting the Attachment	13
Equipment Condition	13
Working Overhead	13
Power Lines	13
Use Care with Hydraulic Fluid Pressure	14
Prioritized Oil Flow	15
Emergency Situations	15
Unsafe Conditions	15
Crystalline Silica Dust	15
Process Material Safely	16
Lift the Load Safely	16
Place the Load Safely	16
PROCESSOR MARKINGS	17
PROCESSOR INSTALLATION	18
Dual-Pump Flow	18
ROTATOR INSTALLATION	20
Foot Switch Installation	20
Rotation Circuit	21
LOCK PIN ELECTRICAL INSTALLATION	22
HYDRAULIC START-UP	23
Start-up Procedure	23
JAW SET CHANGE-OVER	24
MAINTENANCE SAFETY	26
MAINTENANCE SCHEDULE	28

TABLE OF CONTENTS

Four-Hour Checklist.....	28
Eight-Hour Checklist.....	28
Long-term Maintenance.....	29
LUBRICATION POINTS.....	30
SHEAR JAW SET MAINTENANCE.....	31
Blade Bolts.....	31
PIERCING BLADES.....	32
Replacement.....	34
GUIDE BLADES.....	35
Shimming.....	35
Rotation.....	36
Replacement.....	36
Adjustment Plates.....	36
PRIMARY AND SECONDARY BLADES.....	37
Removal.....	37
Adjustment Plates.....	38
Rotation.....	38
Blade Gap.....	39
Blade Gap Measuring Procedure.....	39
Shimming.....	39
RAZOR BLADE.....	40
CRACKER JAW SET MAINTENANCE.....	41
Concrete Cracking Tips.....	41
Cutting Blades.....	43
Blade Removal.....	43
Blade Rotation.....	43
Blade Gap.....	43
Blade Gap Measuring Procedure.....	44
Shimming Procedure.....	44
PULVERIZER JAW SET MAINTENANCE.....	45
Pulverizing Teeth.....	45
GENERAL WELDING GUIDELINES.....	46
Welding Ground Clamp.....	46
Welding Rules.....	46
HARD-SURFACING.....	47
SHEAR JAW BUILD-UP.....	48
SHEAR JAW HARD-SURFACING PATTERNS.....	49
CRACKER JAW WELDING MAINTENANCE.....	50
Build-Up.....	50
Hard-Surfacing Patterns.....	50
PULVERIZER JAW WELDING MAINTENANCE.....	51
Build-Up.....	51
Hard-Surfacing Patterns.....	51
HYDRAULIC/ROTATION MAINTENANCE.....	52

TABLE OF CONTENTS

Hydraulic Requirements.....	52
Rotation Valve Input.....	52
Rotation Valve Settings.....	52
GenFlow Regeneration Valve.....	53
Regeneration Valve Adjustment.....	53
GENFLOW REGENERATION VALVE - HOW IT WORKS.....	54
GENFLOW REGENERATION VALVE.....	55
6360004.....	55
6300763.....	55
SLEWING RING MAINTENANCE.....	56
GEARBOX MAINTENANCE.....	57
Planetary Gearbox Lubrication.....	57
Gearbox Lube Change-out Procedure.....	57
ROTATION CIRCUIT.....	58
Auxiliary Valve Rotation.....	58
Gear Pump Rotation.....	59
TROUBLE-SHOOTING GUIDE.....	60
Processor.....	60
Rotator.....	61
Lock-Pin.....	62
WARRANTY.....	63
Claim Procedure.....	63
Blade Warranty.....	63
PARTS ORDER POLICY AND PROCEDURE.....	64
Parts Orders Should Include.....	64
Placing Orders.....	64
Part Numbers.....	64
Shipping.....	64
Invoices.....	64
Returns.....	64
Warranty Returns.....	64
PARTS ORDER FORM.....	65

TABLE OF CONTENTS

PARTS	66
Third-Member Mount Upper Head.....	67
Second-Member Mount Upper Head.....	68
Multi-Processor Body.....	69
Shear Jaw Set Pivot Group.....	70
Concrete Cracker Jaw Set Pivot Group.....	71
Concrete Pulverizer Jaw Set Pivot Group.....	72
Hydraulics.....	73
Shear Jaw Set.....	74
Concrete Cracker Jaw Set.....	75
Concrete Pulverizer Jaw Set.....	76
Rotation Drive System LXP 200/300.....	77
Rotation Drive System LXP 400/500.....	78
Electrical.....	79
TOOL LIST	80
BOLT TORQUE SPECIFICATIONS	81
THREAD TREATMENT DIAGRAM	82
Mobile Shears.....	82
Processors.....	83
PROCEDURES	84
Cleaning.....	84
Threadlocker.....	84
Anti-Seize.....	85
No Thread Treatment.....	85
BOLT TORQUE SPECIFICATIONS	86
Dry Torque Values.....	86
Wet Torque Values.....	86
O-RING BOSS & FLAT FACE O-RING TORQUE SPECIFICATIONS	87
BOLT DRIVE SPECIFICATIONS	88
CONTACT INFORMATION	89

SAFETY STATEMENTS



This symbol by itself or used with a safety signal word throughout this manual is used to call attention to instructions involving your personal safety or the safety of others. Failure to follow these instructions can result in injury or death.



DANGER

This statement is used where serious injury or death will result if the instructions are not followed properly.



WARNING

This statement is used where serious injury or death could result if the instructions are not followed properly.



CAUTION

This statement is used where minor or moderate injury could result if the instructions are not followed properly.

NOTICE

This statement is used where property damage could result if the instructions are not followed properly.

OPERATIONAL SAFETY

Read Manual Before Operating or Maintaining the Attachment



Read this manual before attempting to operate the attachment. This operator's manual should be regarded as part of the attachment. For proper installation, operation and maintenance of the attachment, operators and maintenance personnel must read this manual.



WARNING

Serious injury or death could result if appropriate protective clothing and safety devices are not used.

Personal Protection

Use protective clothing and safety devices appropriate for the working conditions. These may include but are not limited to:

- ✓ Hard hat
- ✓ Safety glasses, goggles or face shield
- ✓ Hearing protection
- ✓ Safety shoes
- ✓ Heavy gloves
- ✓ Reflective clothing
- ✓ Respirator or filter mask



Safety matters

Know Your Equipment



Know your attachment's capabilities, dimensions and functions before operating. Inspect your attachment before operating and never operate an attachment that is not in proper working order. Remove and replace any damaged or worn parts.

Before Operating

- ✓ Warn all others in the area that you are about to start operation.
- ✓ Perform the Check the Equipment steps outlined in this manual.
- ✓ Check underneath and around the machine. Make sure all personnel and equipment are clear from the area of operation and equipment movement. Check clearances in all directions, including overhead.
- ✓ Be properly seated in the operator's seat.
- ✓ Do not attempt to operate until you have read and fully understand this manual and the OEM manual for the carrier.

OPERATIONAL SAFETY

Check the Equipment

Before use, check the equipment to ensure it is in good operating condition.

Check the following:

- ✓ Grease fittings. Pump grease at all fitting locations, see page 30.
- ✓ Hydraulic fluid level. Add hydraulic fluid as required.
- ✓ Hydraulic hoses and hose connections for wear or leaks. Repair or replace any damaged hoses or connections.
- ✓ All control levers for proper operation.
- ✓ Rotation bearing. Visually check for loose or damaged bolts. If repair is required, refer to qualified personnel.
- ✓ Grease rotation bearing and pinion gear.
- ✓ Check for loose or missing pin retaining bolts.
- ✓ Check cylinders for dents (barrel) or dings (rod).



**GOOD
CONDITION**



WARNING

Serious injury or death could result if warnings or instructions regarding carrier stability and the work area are not followed properly.

Stability

Your Genesis attachment is sized for carrier stability. However, improper operation, faulty maintenance or unauthorized modifications may cause instability.

- ✓ Know the working ranges and capacities of the carrier to avoid tipping.
- ✓ Use the recommended carrier counter weight.

The following conditions affect stability:

- Ground conditions
- Grade
- Weight of attachment
- Contents of attachment
- Operator judgement



For greater stability, knuckle the attachment to bring the load closer to the center of rotation (center of gravity) while lifting. Use extra caution during reaching to avoid tipping.

OPERATIONAL SAFETY

Know the Work Area

Check clearances in the work area. Keep all bystanders at a safe distance. Do not work under obstacles. Always check your location for overhead and buried power lines or other utilities before operation.

Check ground conditions. Avoid unstable or slippery areas. Position the carrier on firm level ground. If level ground is not possible, position the carrier to use the attachment to the front or back of the carrier. Avoid working over the side of the carrier.

To reduce the risk of tipping and slipping, never park on a grade exceeding 10% (one-foot rise over the span of a ten-foot run).

Starting Procedure

Before operating, walk completely around the equipment to make certain no one is under it, on it or close to it. Keep all bystanders at least 75 feet away from the area of operation and equipment movement. Let all other workers and bystanders know you are preparing to start. DO NOT operate until everyone is clear.

Always be properly seated in the operator's seat before operating any carrier controls.

To start:

- ✓ Make sure all controls are in the center (neutral) position.
- ✓ Be properly seated.
- ✓ Slowly operate all functions to check for proper operation and to bleed air from the hydraulic system.

To shut down:

- ✓ Return your Genesis attachment to a rest position on the ground.
- ✓ Shut off the carrier engine.
- ✓ Work controls in all directions to relieve hydraulic pressure, per excavator manufacturer's instructions.



Serious injury or death could result if warnings or instructions regarding safe operation are not followed properly.

Place the Load Safely

Do not move the attachment, or anything held in the jaws, over people, equipment or buildings. Do not throw or drop the contents. Operate the controls smoothly and gradually.

OPERATIONAL SAFETY

Safely Operate Equipment

Do not operate equipment until you are trained by a qualified operator in its use and capabilities.

See your carrier's manual for these instructions.

- ✓ Operate only from the operator's seat. Check the seat belt daily and replace if frayed or damaged.
- ✓ Do not operate this or any other equipment under the influence of drugs or alcohol. If you are taking prescription medication or over-the-counter drugs ask your medical provider whether you can safely operate equipment.
- ✓ Never leave equipment unattended with the engine running or with the attachment in a raised position. Apply the brakes before exiting the equipment.
- ✓ Do not exceed the lifting capacity of your carrier.
- ✓ Avoid conditions that can lead to tipping. The carrier can tip when operated on hills, ridges, banks and slopes. Avoid operating across a slope which could cause the carrier to overturn.
- ✓ Reduce speed when driving over rough terrain, on a slope, or when turning to avoid overturning the carrier.
- ✓ Never use the attachment as a work platform or personnel carrier.
- ✓ Keep all step plates, grab bars, pedals and controls free of dirt, grease, debris and oil.
- ✓ Never allow anyone to be around the equipment when it is operating.
- ✓ Do not operate poorly maintained or otherwise faulty equipment. Inform the proper authority and DO NOT resume operation until the problem has been fixed.
- ✓ Do not alter or remove any safety features.
- ✓ Know your work site safety rules as well as traffic rules and flow. When in doubt on any safety issue, contact your supervisor or safety coordinator for an explanation.
- ✓ A heavy load can cause equipment instability. Use extreme care during travel. Slow down on turns and watch out for bumps. The equipment may need additional counter-weights to counterbalance the weight of the attachment.



OPERATIONAL SAFETY

Transporting the Attachment

- ✓ Travel only with the attachment in a safe transport position to prevent uncontrolled movement. Drive slowly over rough ground and on slopes.
- ✓ When driving on public roads use safety lights, reflectors, Slow Moving Vehicle signs, etc., to prevent accidents. Check local government regulations that may affect you.
- ✓ Do not drive close to ditches, excavations, etc., as cave-in could result.
- ✓ Do not smoke when refueling the prime mover. Allow room in the fuel tank for expansion. Wipe up any spilled fuel. Secure cap tightly when done.

Equipment Condition

Never operate poorly maintained equipment. When maintenance is required, repair or replace parts immediately.



WARNING

Serious injury or death could result if warnings or instructions regarding working overhead are not followed properly.

Working Overhead

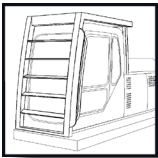

Avoid handling material overhead whenever possible. Safety glass and wire mesh cab guarding must be installed to protect the operator from flying debris that may be created during handling. Falling Object Protection Structures, or FOPS, are necessary for any application where material is to be handled overhead.



DANGER

Serious injury or death will result if warnings or instructions regarding power lines are not followed properly.

Power Lines

Do not operate the machine near energized power lines. All local, state/provincial and federal regulations must be met before approaching power lines, overhead or underground cables, or power sources of any kind with any part of the carrier or attachment. Always contact the appropriate utility when operating near power lines. The lines should be moved, insulated, disconnected or de-energized and grounded before operating in the area.



Current in high voltage lines may arc some distance from the wire to a nearby ground. Keep all parts of the machine at least 50 feet (16m) away from power lines.

OPERATIONAL SAFETY



WARNING

Serious injury or death could result if warnings or instructions regarding hydraulic fluid pressure are not followed properly.

Use Care with Hydraulic Fluid Pressure

Hydraulic fluid under pressure can penetrate the skin and cause serious injury or death. Hydraulic leaks under pressure may not be visible.

- ✓ Keep unprotected body parts, such as face, eyes and arms as far away as possible from a suspected leak. Flesh injected with hydraulic fluid may develop gangrene or other permanent injuries.
- ✓ If injured by injected fluid see a doctor immediately.
- ✓ Wear safety glasses and protective clothing and use a piece of cardboard or wood when searching for hydraulic leaks.

Do Not Use Your Hands!
See illustration below.

- ✓ Hydraulic oil becomes hot during operation. Do not let hydraulic oil or components contact skin, as it could cause severe burns. Allow hydraulic components to cool before working on them. Use appropriate protective clothing and safety equipment. If burned, seek immediate medical attention.

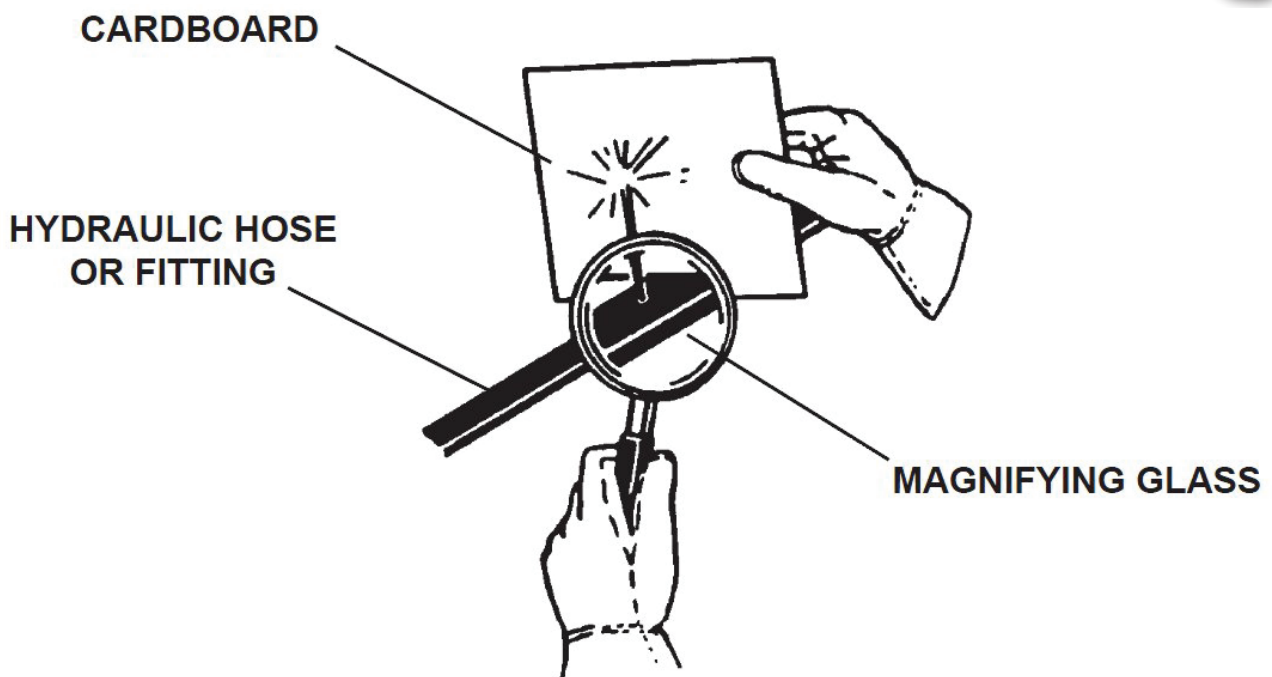

OPERATIONAL SAFETY

Prioritized Oil Flow

Equipment operators must ensure there is prioritized oil flow to the main valves in overhead operations or high reach conditions.

Emergency Situations

Always be prepared for emergencies. Make sure a fire extinguisher is available. Be familiar with its operation. Make sure to inspect and service the fire extinguisher regularly. Make sure a first aid kit is readily available.



Unsafe Conditions

Do not operate if an unsafe condition exists. Stop operation immediately, shut down the machine and report the unsafe condition to the proper authority. Equipment operation and maintenance practices directly affect your safety and the safety of those around you. Always use common sense while operating and be alert to unsafe conditions.

Crystalline Silica Dust

It is recommended to use dust suppression, dust collection and if necessary, personal protective equipment during the operation of any attachment that may cause high levels of dust.

 **DANGER** Exposure to respirable crystalline silica dust along with other hazardous dusts may cause serious or fatal respiratory disease.

IMPORTANT: Concrete and masonry products contain silica sand. Quartz, which is a form of silica and the most common mineral in the Earth's crust, is associated with many types of rock.

Some activities that may have silica dust present in the air include demolition, sweeping, loading, sawing, hammering, drilling or planing of rock, concrete or masonry.

It is recommended to use dust suppression (such as water) or dust collection (such as a vacuum) along with personal protective equipment if necessary during the operation of any attachment that may cause high levels of silica dust.



OPERATIONAL SAFETY



WARNING

Using your Genesis attachment in unauthorized applications may create an unsafe situation and will void the warranty.

Process Material Safely

- Do not process hardened steel material such as tool steel, railroad rail, axles, springs, machined parts or high-strength material. Hardened/high-strength material breaks, rather than shears, which may cause flying debris. It will also cause damaging decompression spikes to your Genesis attachment and base carrier hydraulic systems.
- Do not operate any functions of the carrier while cutting or crushing with your attachment, including boom and drive functions.
- Do not pull down structures with your Genesis attachment. Doing so may cause falling debris or material to break free and exceed the capacities of the carrier, causing a tipping hazard and rotation component failures.
- Do not use rotation to pry or break material. Doing so exerts high back-driving forces and spikes to the rotation circuit components that cannot be cushioned hydraulically. It may also cause motor and gearbox failures. The rotator should only be used for positioning an attachment.
- Do not process pressurized containers unless the main valve has been removed and you are absolutely certain the container is empty.
- Do not process spring loaded brake chambers and automotive struts as the release of compressed springs is extremely dangerous. Nothing made of spring material or containing springs should be processed.

Lift the Load Safely

- The hydraulic system has been preset and tested by your dealer. Do not alter hydraulic settings without consulting an authorized Genesis dealer or the Genesis Service Department. Doing so will void the warranty and may cause structural damage, accidents or tipping.
- Make sure the load is held securely in the jaws. Do not move a loaded attachment if load is loose or dangling. Make sure the load is pinched between the jaws – never cradle a load.
- For greater stability, knuckle the attachment to bring the load closer to the center of rotation (center of gravity) while lifting. Use extra caution during reaching to avoid tipping.

Place the Load Safely

- Do not move the attachment, or anything held in the jaws, over people, equipment or buildings. Place the load gently. Do not throw or drop the contents.
- Operate the controls smoothly and gradually. Jerky controls are hazardous and may cause damage to the carrier.
- Avoid fire hazards. Keep the area clean. Remove all flammable materials from the area during any welding or heating process. Have a fire extinguisher nearby and know how to use it.
- Never substitute pins or bolts. Use factory supplied pins. Replace all bolts with the same size and grade. Failure to do so may cause serious injury or death.
- Use your Genesis attachment only as directed in this manual. Do not use the attachment to lift and move other objects. Doing so may cause instability and tipping.

PROCESSOR MARKINGS

Decals are necessary for safe operation and maintenance. To reorder, contact your Genesis dealer or call 715-395-5252.

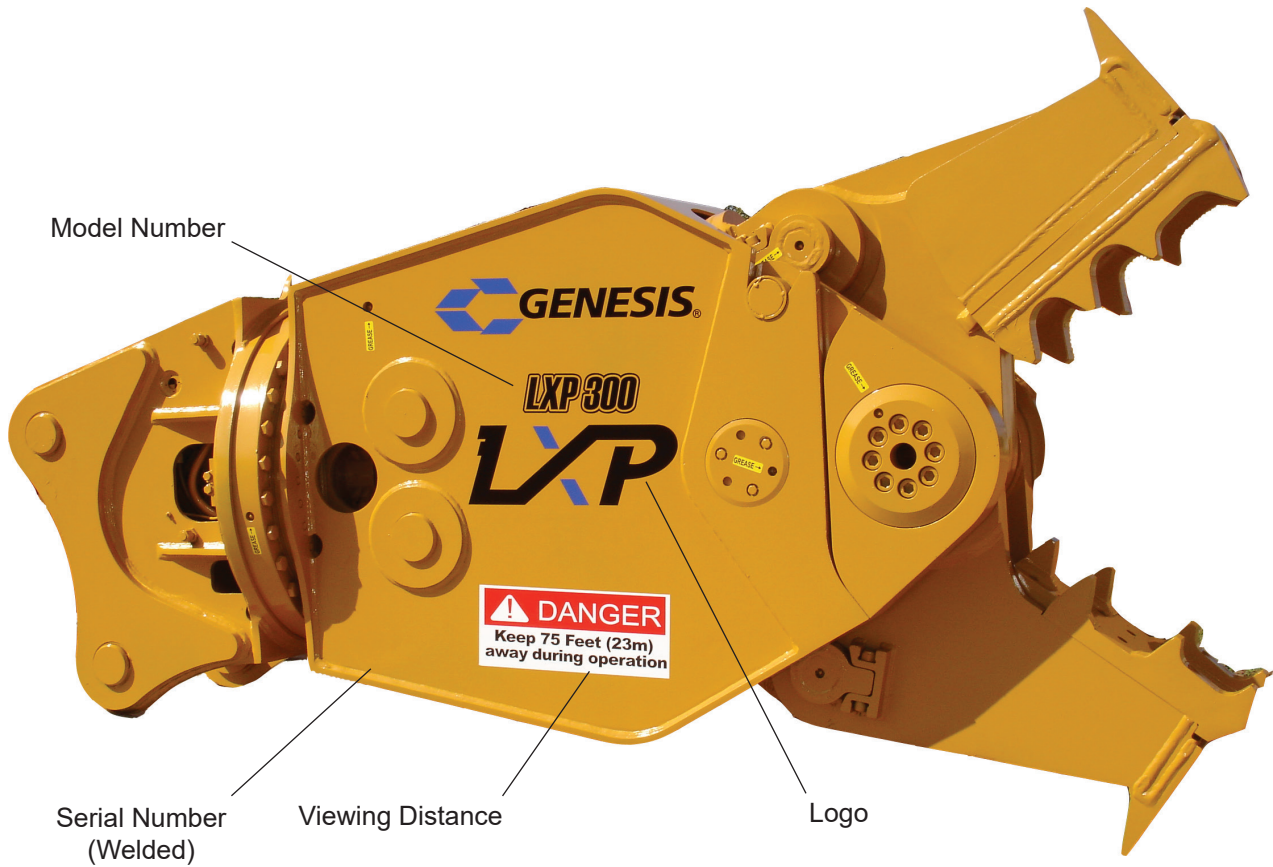

PROCESSOR INSTALLATION

Preparation of the excavator prior to attachment delivery will make installation safer and easier. Contact Genesis or your Genesis dealer for assistance.

Dual-Pump Flow

An excavator typically has two hydraulic pumps that supply oil to its main control valve, which is usually separated into two halves. Combining the flow from both halves of the control valve is called summing, thus achieving dual-pump flow to operate one circuit.

Summing is the preferred method of achieving maximum speed to an attachment. However, interchanging the stick and bucket circuits may also substantially increase speed.

A bucket circuit is usually single-pump flow while a stick circuit is dual-pump flow. At times, adding an auxiliary circuit spool to the stick circuit helps reduce back pressure in the system and speed up jaw open and close.

In certain cases, the bucket and auxiliary circuits can be summed to achieve dual-pump flow, depending on whether the bucket and auxiliary are on separate sides of the main valve and whether the auxiliary circuit can be proportionally controlled by teeing into the bucket pilot control circuit.

The auxiliary circuit must also be capable of proportionally controlling pump initiation on the auxiliary side of the circuit. On many excavators, the auxiliary circuit is controlled by the flow percentage set in the operating system. Because attachments take all the flow the pumps can give them, when this percentage is reached, the pump will instantly turn on or off instead of gradually increasing or decreasing, which can cause sharp, damaging spikes in the hydraulic circuit.

If excavator circuits are electronically controlled, it may be necessary to reduce the spool shift and pump initiation in the excavator software to take spiking out of the circuit when changing attachment cylinder direction from full extend or full retract.

On excavators with full hydraulic spool piloting, install a flow control into the pilot lines between the joystick and spools. The flow control can then be adjusted to slow the pilot oil flow to the spool, which in turn slows how the spool shifts and the pumps stroke up.

PROCESSOR INSTALLATION



WARNING

Be sure hydraulic pressure is relieved before disconnecting hydraulic fittings. Remove necessary fittings SLOWLY.

The attachment is usually shipped in an upright position. Extreme care must be used when inverting the attachment for installation.

Follow the excavator OEM's removal and safety instructions to remove the bucket or other stick attachments.

Position the attachment upside down on flat, solid ground. Blocking may be required to raise the mounting bracket into proper position.

Track the excavator to the attachment with the jaws facing the operator. Lift the excavator stick over the attachment, carefully positioning the stick tip connection with the attachment mounting main pivot bore. Pin the excavator stick to the attachment.

Slowly raise the boom to lift the attachment, allowing the cylinder pivot connection to come within range of the excavator cylinder stroke.

Extend the excavator cylinder until the power link bore lines up with the cylinder pivot connection. Pin the excavator cylinder to the attachment.

Crowd and extend the attachment, checking closely to make sure there is no interference between the bracket and hard lines. Also check for interference between the cylinder and boom/stick.

Install excavator hydraulic hoses, supply and return, from the stick tip to the attachment manifold blocks.

The stick and bucket circuits are oriented as to rod and bore sides of their respective cylinders. Be sure to connect rod-to-rod and bore-to-bore when connecting a circuit to the attachment. When these are reversed, extra pressure is needed to open the jaw, which pulls down the engine, de-strokes the pumps, increases jaw cycle time, creates high oil temperature and burns more fuel.

The attachment must be vertical before putting oil into it or an air lock in the regen valve may prevent the jaw from opening.

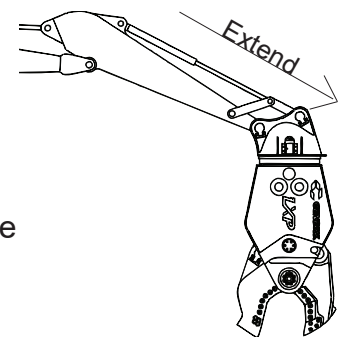
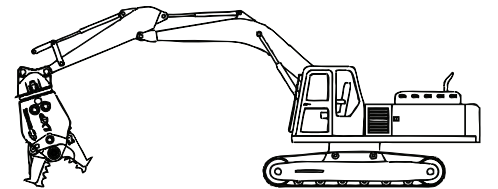
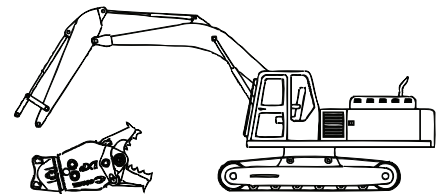
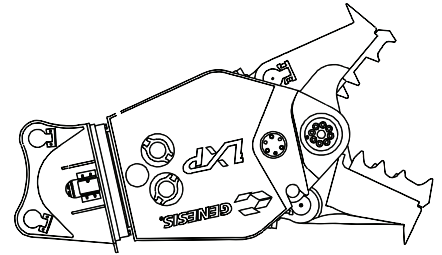

WARNING

Removing any connecting pin may be hazardous. To remove a connecting pin, position the attachment on the ground and properly support. Particles may fly when a pin is struck. Use a drift pin or mallet when striking pins. Keep all personnel at a safe distance.

ROTATOR INSTALLATION

Run the case drain / lock pin return line from the rotation head of the processor to the filter on the excavator hydraulic reservoir. The line must be rated minimum 250 PSI working pressure and must be at least 1/2" for all LXP® models. The maximum case-drain pressure measured at the processor while rotating and cycling the jaws must never exceed 125 PSI.

Use the correct fittings. Secure the line to the excavator stick.

Note: LXP 200 / 300 models require a return line for the lock pin but do not require a case drain.

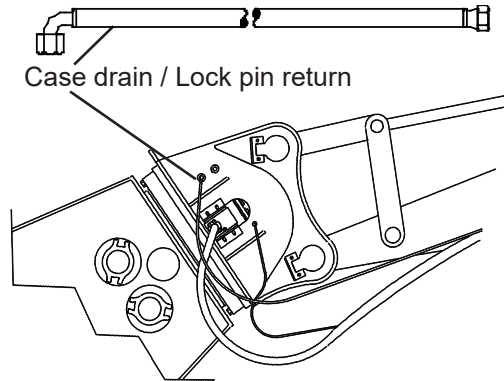

Foot Switch Installation

Install the foot switch in the excavator and connect with electrical harness. Consult excavator dealer when using an alternate to the Genesis supplied foot switch.

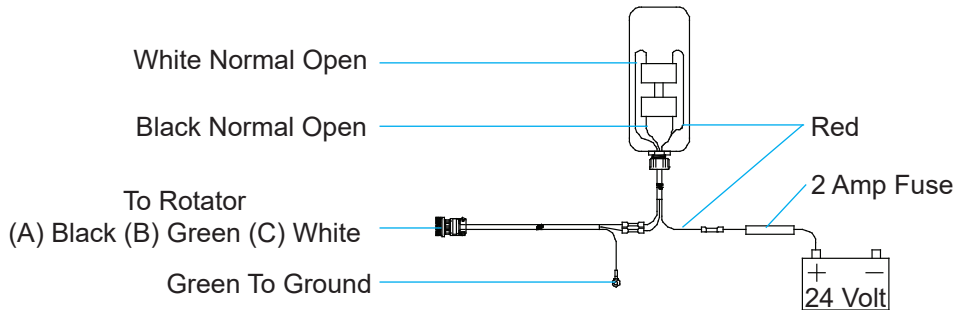

ROTATOR INSTALLATION

Rotation Circuit

The rotator requires an additional hydraulic circuit. This diagram shows the installation of the additional circuit. Refer to the Hydraulic/Rotation Maintenance section of this manual for valve descriptions, functions and settings.

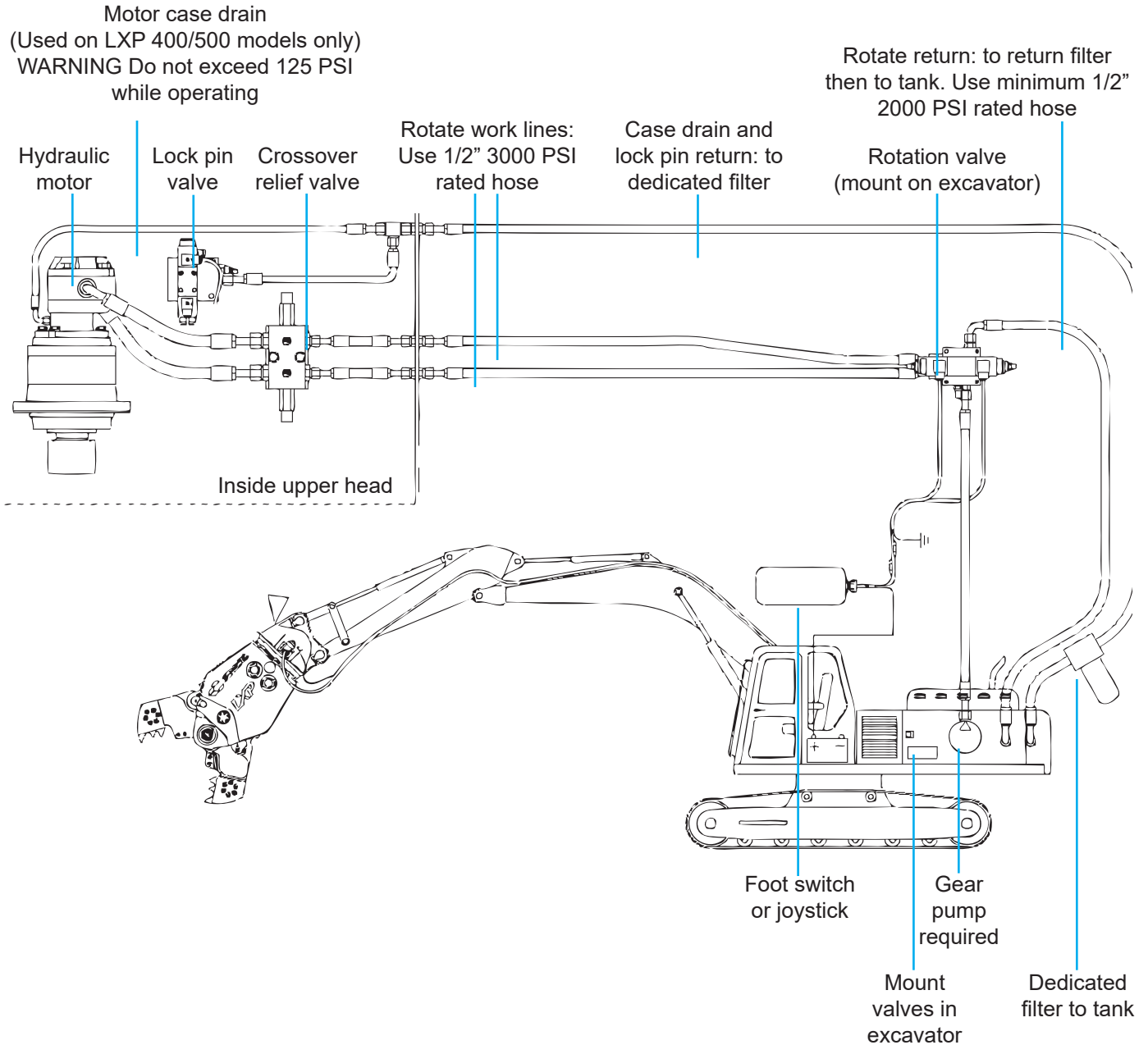

LOCK PIN ELECTRICAL INSTALLATION

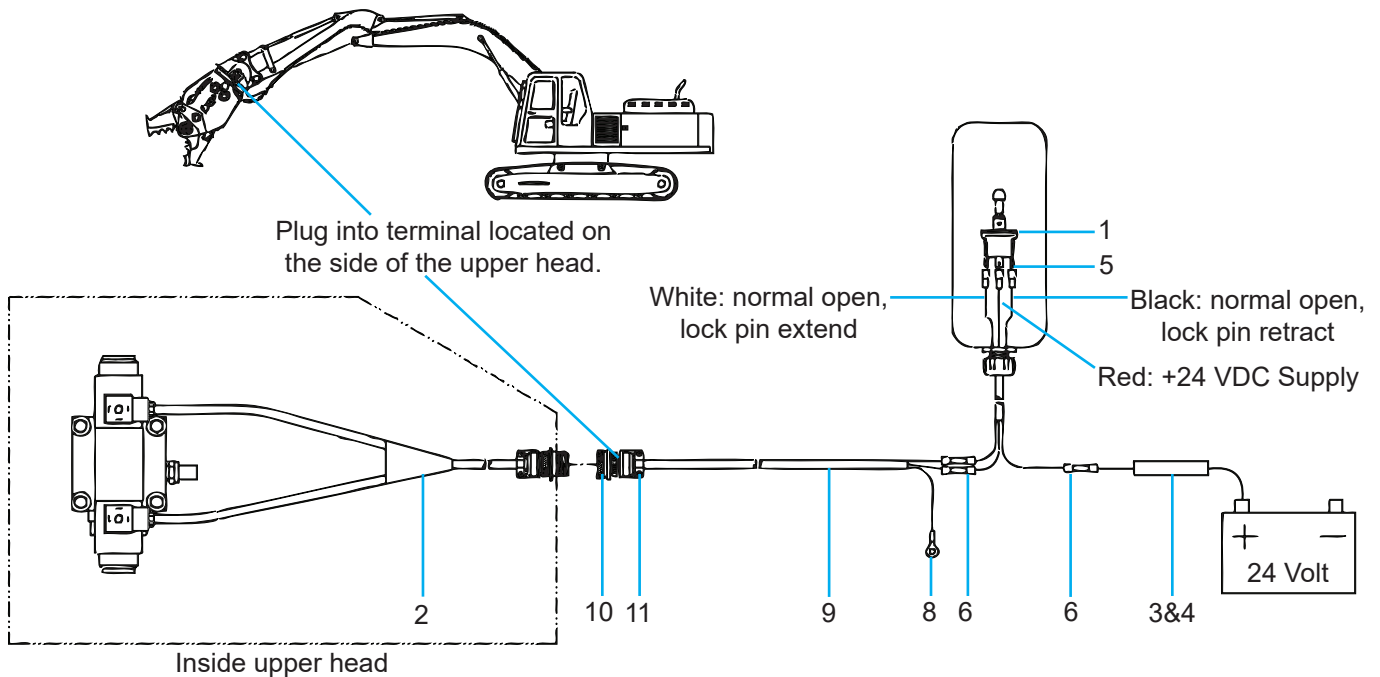

ASSEMBLY 3500211

Item	Description
1	Mount three-way locking toggle switch in excavator cab
2	Lock pin wiring harness sub-assembly 3500209 inside upper head
3	Fuse holder
4	Two-amp fuse
5	Insulated connectors
6	Butt connectors: white to white, black to black, red to fuse/battery
7	Cable ties (not shown)
8	Insulated ring terminal; green to ground
9	Cable; use cable ties to secure along stick/boom
10	Plug connector into terminal located on the side of the upper head
11	Cable clamp

HYDRAULIC START-UP

Genesis processors are designed to operate under full excavator pressure or up to 5500 PSI. Due to these high pressures, it is important that air is bled from the processor cylinders after installation. Failure to follow these procedures could result in cylinder seal damage and/or excavator hydraulic system damage.

Start-up Procedure

- ✓ Check the excavator hydraulic tank for proper fluid level.
- ✓ Excavator oil should be warmed up before hooking up processor lines in cold weather. If oil is cold, air from the cylinder will be pushed into the oil tank, causing the oil to foam. This problem takes hours to correct and may cause pump cavitation.
- ✓ Follow the OEM procedures for starting and warming the excavator hydraulic system. Do not operate the processor circuit during the warm-up period.
- ✓ After the excavator has reached normal operating temperature, set the engine to idle speed.
- ✓ The processor must be vertical. Do not allow the tank to run low - have someone watch the oil gauge.
- ✓ Slowly fill the bore end of the processor cylinders to partially close the jaws.

NOTICE

Do not fully extend or retract processor cylinders with the first cycles.

Slowly fill the rod end of the processor cylinders to open the jaws. Use partial strokes extending and retracting, slowly working to full strokes.

Stop and check the excavator hydraulic fluid level again to be sure there is still sufficient fluid. Service as required.

Cycle the processor jaws five or six strokes before increasing to full operating pressure.

JAW SET CHANGE-OVER

Jaw set change-over requires at least one worker on the ground in addition to the operator. Use basic safety precautions. All personnel on the ground must stand clear during operation.

Change-over Procedure:

- Lower processor into stand. Lightly clamp jaw to middle plate.
- Remove cylinder pins. Grease lock pin. Remove safety plates.
- Retract cylinders.
 - While continuing to hold processor cylinder retract lever (jaw open), hit electric switch to retract lock pin.
 - Ensure both sides of lock pin have retracted. One side may fully retract before the other begins to retract.
- Articulate processor body to disengage jaw set.
- Position processor body at new jaw set.
- Check lock pin bores in new jaw set. Wipe bore clean to ensure there are no contaminants. Clean quick plate trunion pins and mating “U” in processor body.

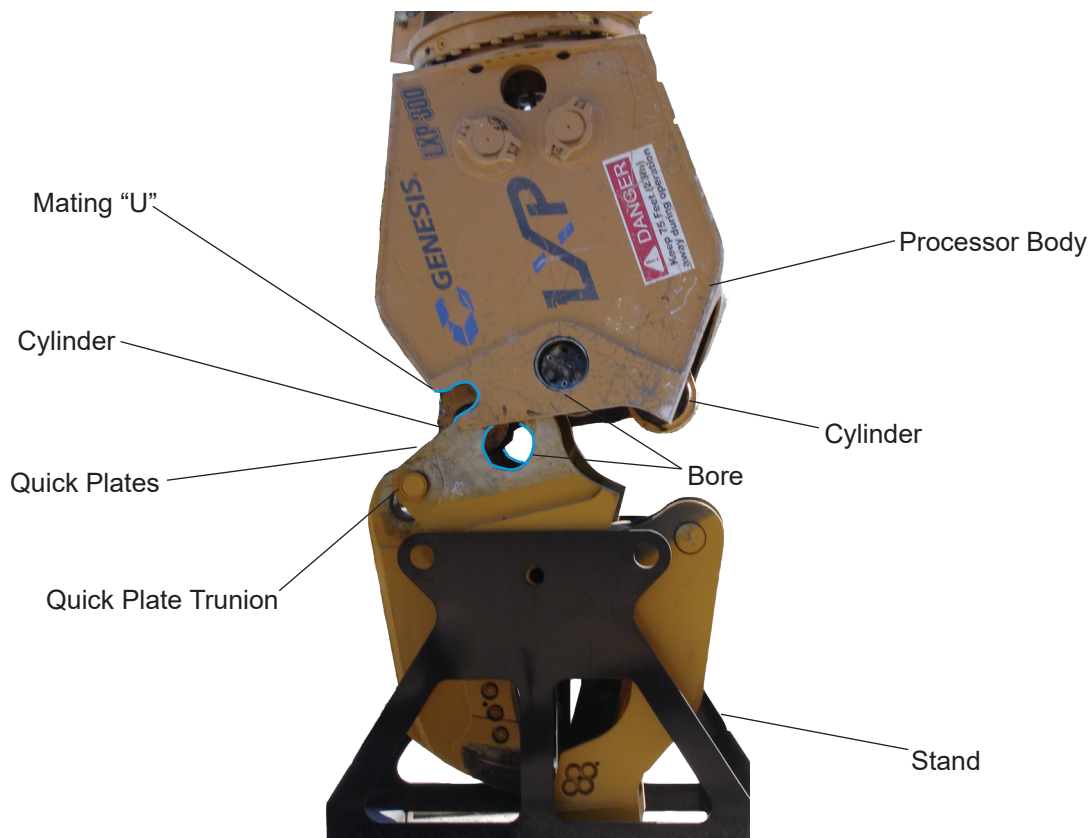

JAW SET CHANGE-OVER

Articulate processor body to engage jaw set.

- Both left and right trunion pins must be seated in processor cradle.
- Lock pin bore must be aligned with quick plate bore.

Once quick plate is aligned, hold processor cylinder retract lever and hit electric switch to extend lock pin. Make sure both sides of lock pin are completely extended. Note: One side may fully extend before other side begins to extend.

Shut off the machine.

Reinstall safety plates after the machine is shut off.

Slightly extend cylinders to ensure clearance at center formed plate in jaw set.

Articulate processor so one cylinder is vertical. Extend or retract cylinder to align with jaw bore.

Ensure bores are free of contaminants; install pin.

Repeat for second cylinder.

Grease cylinder pins, lock pins and pivot group.

Open jaw and remove processor from stand. Cycle jaws several times to ensure change-over is successful.

Note: Keep lock pin bores greased during storage.

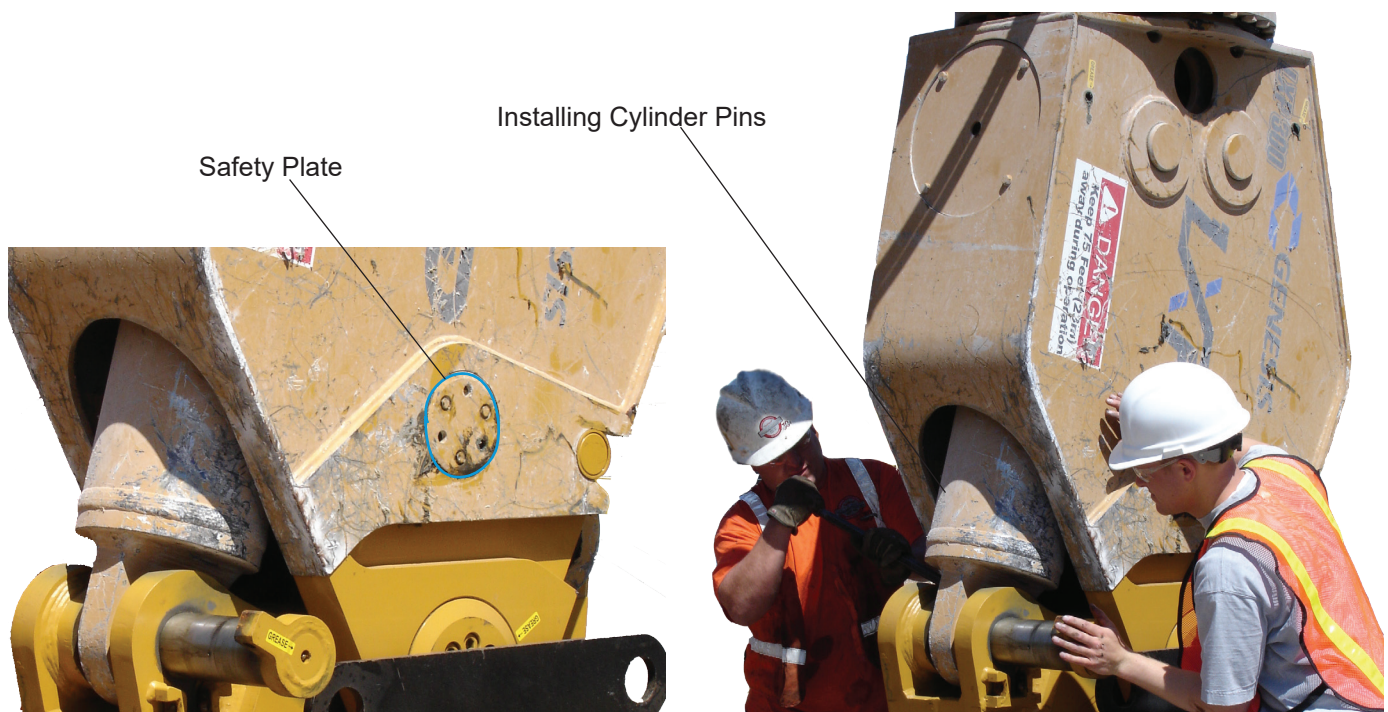

MAINTENANCE SAFETY

Only trained and authorized persons should perform maintenance on the processor. To be qualified, you must understand the instructions in this manual, have training, and know the safety rules and regulations of the job site.

Do not alter the physical, mechanical or hydraulic operation of the processor. Doing so may cause a dangerous situation for yourself and those around you and will void the warranty.

Do not attempt repairs you do not understand. If any questions arise regarding a safety or maintenance procedure, contact Genesis or your Genesis dealer.

Read this entire manual. All personnel must understand the maintenance and safety procedures.

Use factory authorized parts. The use of unauthorized parts may compromise safety, performance and durability of the processor and may void the warranty.

Follow the daily checklist and maintenance schedules in this manual. Extreme conditions may dictate shorter maintenance intervals.

Do not exceed bolt torque specifications. See the Bolt Torque Specifications section of this manual, page 81.

Do not weld on structural components without consulting Genesis. Doing so may cause structural failure and void the warranty.

Do not operate a processor without the case-drain/lock pin return line properly installed. Doing so will cause immediate failure of the rotate motor and gearbox.

Do not work on the processor before ensuring it will not move. Completely lower the boom to the ground or a rest position and relieve hydraulic pressure.

Never operate poorly maintained equipment. When maintenance is required, repair or replace parts immediately.

Do not operate under unsafe conditions. If an unsafe condition arises during operation, immediately shut down the equipment and report the situation to the proper authority.

MAINTENANCE SAFETY

Do not work on any hydraulic lines or components while they are pressurized. Escaping hydraulic fluid can penetrate the skin, causing serious injury or death. Relieve pressure before performing maintenance. Keep hands and body parts away from pin holes and nozzles, which eject fluids under high pressure. Use a piece of cardboard to search for leaks.



If fluid is injected into the skin, seek medical assistance immediately from a doctor familiar with this type of injury.

NOTICE

See “Use Care with Hydraulic Fluid Pressure”, page 14

Hydraulic oil becomes hot during operation. Do not let hydraulic oil or components contact skin, as it could cause severe burns. Allow hydraulic components to cool before working on them. Use protective clothing and safety equipment.



Remove paint before welding or heating. Hazardous fumes/dust can be generated when paint is heated by welding, soldering or using a torch. Do all work outside or in a well ventilated area and dispose of paint and solvent properly.

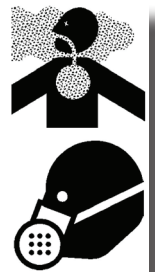

When sanding or grinding paint, avoid breathing the dust. Wear an approved respirator. If you use solvent or paint stripper, remove stripper with soap and water before welding. Remove solvent or paint stripper containers and other flammable materials from area. Allow fumes to disperse at least 15 minutes before welding or heating.

Avoid fire hazards. Keep the area clean. Remove all flammable materials from the area during any welding or heating process. Have a fire extinguisher nearby and know how to use it.



Never substitute pins or bolts. Use factory supplied pins. Replace all bolts with the same size and grade. Failure to do so may cause serious injury or death.

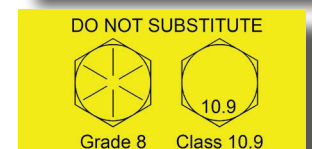

MAINTENANCE SCHEDULE

Performing scheduled maintenance will promote safe, reliable operation of your processor. Use maintenance procedures described in this manual. If you are not able to safely and competently perform these procedures, have a Genesis dealer perform them.

Extreme operating conditions may require shortened maintenance intervals.

Four-Hour Checklist

Inspect:

- Bolts - check for loose bolts, replace if damaged
- Fittings and hoses for damage or leaks
- Bracket pivot for wear and pin retainers
- Cylinder pivot for wear and pin retainers
- Entire processor for cracks (visual check)

Grease:

- Bracket pins (two locations)
- Processor cylinder butt (two locations, ten pumps per fitting)
- Processor cylinder rod (two locations, ten pumps per fitting)
- Main shaft end caps (both sides, five pumps with jaw open, five pumps with jaw closed)
- Main shaft lower (two locations)
- Rotation bearing (four locations)
- Rotation head (two locations)
- Lock pin (both sides)

Eight-Hour Checklist

Perform four-hour checklist plus the following:

Shear jaw set (follow this sequence):

- Check blade tolerance
- Check blade edge radius
- Check for loose or damaged bolts, retorquing loose bolts when cool
- Build-up and hard-surface as required

Concrete pulverizer jaw set:

- Check for loose or damaged bolts, retorquing loose bolts when cool
- Build-up and hard-surface as required

Concrete cracker jaw set:

- Check blade edge radius
- Check for loose or damaged bolts, retorquing loose bolts when cool
- Build-up and hard-surface as required

For all jaw sets:

- Ensure quick plate trunion bushing is intact and not damaged. Damage in this area can cause the lock pin cylinders to back out, preventing the jaw set from releasing.

MAINTENANCE SCHEDULE

Long-term Maintenance

- Grease cylinder pins and lock pins at each jaw set change-over.
- Change gearbox lube after first 50 hours of operation; check every 250 hours; change annually.
- After the first 80 hours of operation, check all bolts, including slewing ring bolts.
- Replace slewing ring bolts every 2000 hours.
- Replace regeneration valve components every 4000 hours.
- Reseal cylinders every 4000 hours.
- Reseal swivel every 4000 hours.

LUBRICATION POINTS



Shut off excavator and disable hydraulics per OEM instructions before greasing.

For normal conditions above 32°F (0°C), use a lithium-based, premium grade 2 extreme-pressure grease. For temperatures below 32°F, use a grade 0 grease.

Do not use grease containing Molybdenum (Moly).

Genesis GLG-2® anti-wear, extreme-pressure lithium grease, PN 6302601, is recommended for all temperature conditions.

The processor jaw must be closed for access to all grease fittings. Grease all fittings every four hours of operation. Grease until extrusion is visible.

After greasing the rotation bearing, rotate the processor through two full rotations.

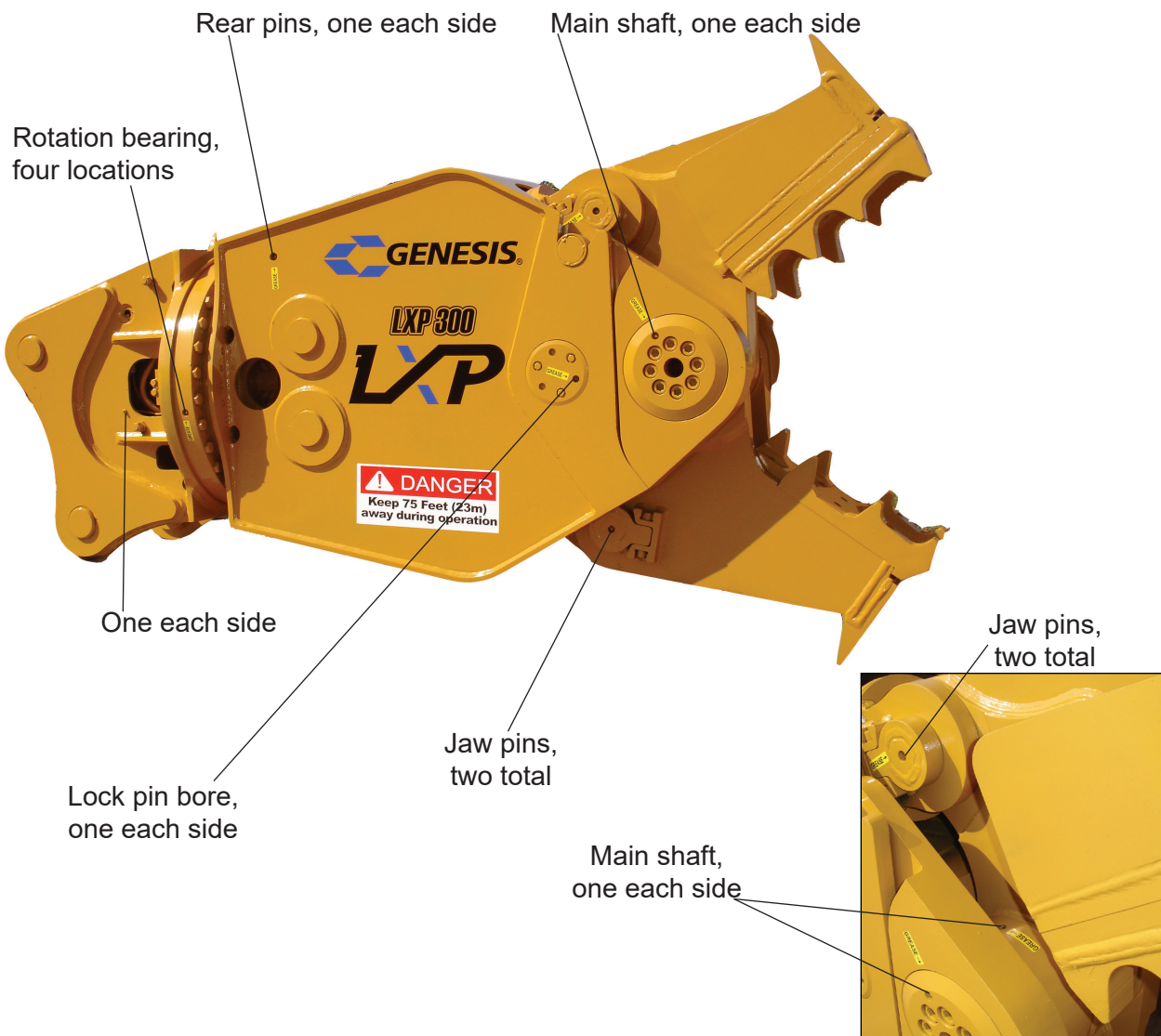

SHEAR JAW SET MAINTENANCE

Blade and jaw maintenance greatly affects performance. To maximize cutting performance and optimize the life of replaceable parts, follow this specific sequence of checks, adjustments and maintenance.

1. Piercing Blades - replace when edges are worn.
2. Guide Blades - rotate, shim to tolerance, and replace when worn. (Note: LXP 200 has only one guide blade.)
3. Primary and Secondary Blades - rotate; replace when all edges are worn. Shim lower blades to tolerance.
4. Razor Blade - rotate and replace when all edges are worn.
5. Welding Maintenance - perform jaw build-up and hard-surface as needed.

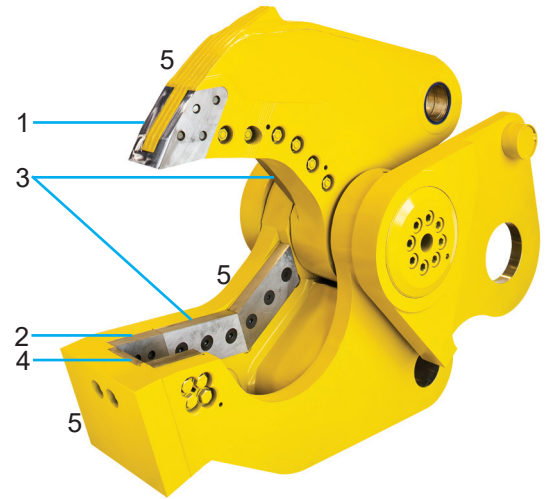

Blade Bolts

Torque blade bolts every eight hours to the specifications listed in the Bolt Torque Specifications section of this manual, see page 81. Check for broken bolts daily and replace them immediately.

PIERCING BLADES

Piercing blade maintenance is crucial to productivity and safe operation. An improper blade gap may cause material jamming and/or blade breakage.

Use the following procedure to check for wear.

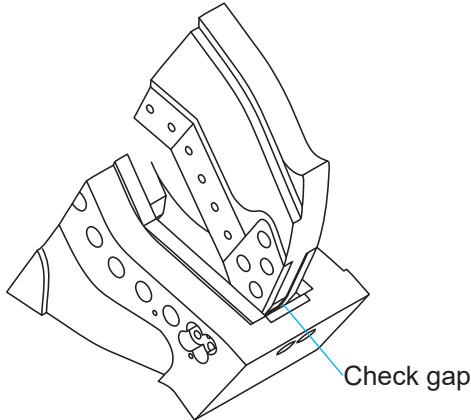

1. Slowly close jaws until the piercing blades are flush with the top edge of the razor blade.
2. Check gap with a tape measure. Acceptable gap is 5/8".
3. Check the condition of the piercing blades with a straight edge or square.
4. Check the profile along the blades.

5. Badly worn blades must be replaced. However, slightly worn blades may be squared up with a grinder and a square. This may be repeated until a maximum of 1/2" of material is removed from the lower piercing edge.

6. Typical use requires blade replacement at approximately 200 hours; heavy piercing requires replacement at approximately 40 hours. These are general guidelines only. Replace blades based on wear not hours of operation.

7. Width of blades, top to bottom, may taper 0.060" (2 mm) total. Bottom edges may be worn to a maximum radius of 3/16".

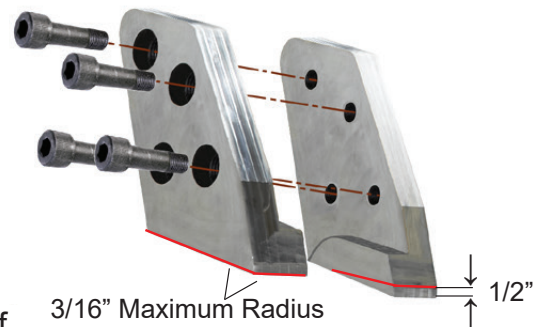

PIERCING BLADES

Piercing blades must fit tightly in some areas while having clearance in others. Piercing blades are made from the same material as the cutting blades to withstand the friction caused by piercing hard materials.

Areas **Highlighted in Blue** require contact fit to the upper jaw and tang to prevent shattering.

Areas **Highlighted in Red** require an air gap, and blades may occasionally need to be ground down to provide clearance.

Piercing blade contact with the clearance areas (**red**) can cause abnormal stress in the blade. This may cause the piercing and/or guide blades to crack, break or shatter.

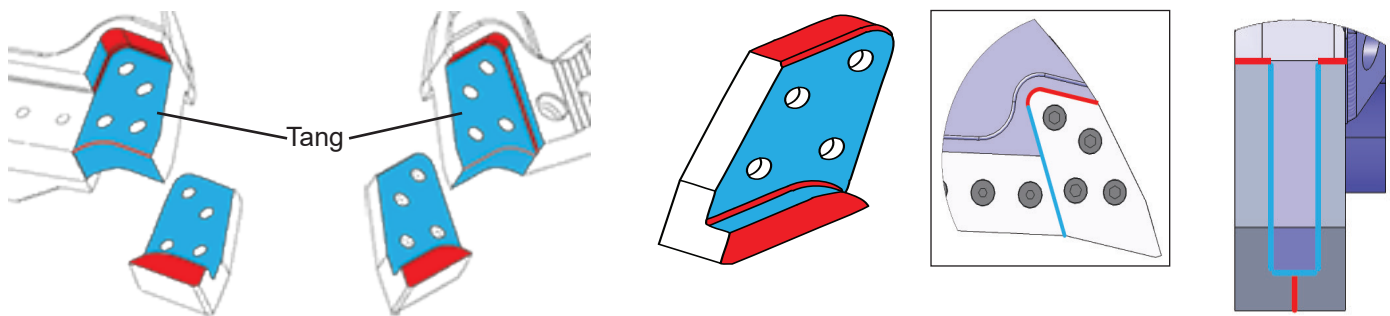

When necessary, build up the front lower edge of the tang and the front vertical surface of the upper (areas **highlighted in yellow**), following the procedures given in this manual. After welding, surfaces should be squared with a grinder and finished with a file and a machinist's straight edge.

It is critical that the piercing blade pocket and tang surfaces are straight and true, without dings, deformations, high or low spots, or areas that are worn away.

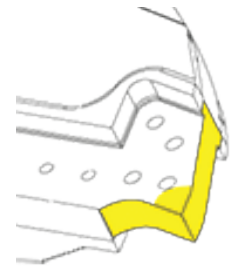

Piercing blade bolts must not make hard contact with the bolt holes in the upper tang. In rare cases it has been noted that improper alignment of piercing blade bolt holes and the bolt holes in the tang can cause the piercing blades to break through the bolt holes.

When installing the piercing blades, the bolts must be freely installed by hand, not with an air impact wrench.

The bolts may start freely, but when the bolt shank, which is larger in diameter than the threads, enters the hole in the tang, the interference can cause side loading to the piercing blades. This can cause the tips to break as they try to force the holes apart, or it may force the tips to seat improperly on the tang which can also cause tip failure. This is not a common issue, but one that should be noted as part of routine tip maintenance to prevent unnecessary costs and downtime. If this situation is encountered, contact the Genesis Parts or Service Departments for further instructions.

PIERCING BLADES

Replacement

1. Remove blades using an air-impact wrench or breaker bar and multiplier.
2. Remove dust and debris from blade seats; wipe down with a rag and solvent.
3. Lightly file deformities from blade seat edges. Do not sand or grind face of blade seats.
4. Install new, clean blades.
5. Snug lubricated blade bolts by hand to hold them in place; push blades up and into the upper and rear surfaces of the seats.
6. Torque bolts to 1/3 of the final torque value.
7. Check for firm contact against blade seats.
8. With a feeler gauge, confirm gap of 0.002" to 0.010" where blades meet at piercing surface. A very narrow gap may be confirmed by shining a flashlight from below the blades and seeing light pass through. If gap exceeds 0.010", call the Genesis Service Department. If no gap exists, remove blades, lightly grind facing surfaces and repeat steps 5-8.
9. Torque bolts to 2/3 final value, and then to final value, using a cross bolt pattern.

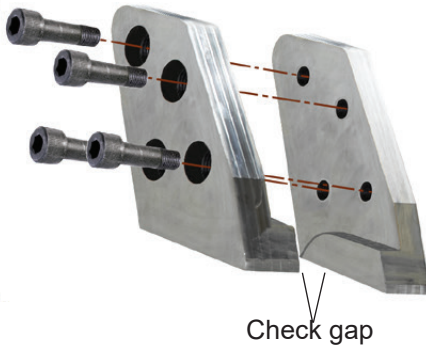

NOTICE

Piercing blade bolts must be lubricated and torqued as specified in the Bolt Torque Specifications section of this manual, see page 81.

Correct clamping force is required to keep tips from moving on their seats. Over-tightening can cause bolt shanks to stretch, losing their clamping force. Loose bolts will cause the seating areas to erode.

GUIDE BLADES

Check guide blade tolerances every eight hours. When necessary, shim the guide blades to keep the gap within the specifications listed in the Blade Gap table below.

Rotate the guide blades when worn to a 1/8" (3 mm) radius. Replace the guide blades when more than 0.075" (2 mm) of shims are required to keep the blade gap within tolerance.

Dual guide blades, one on either side of the lower jaw, allow for a wider tip-to-guide blade gap than is used between the main cutting blades. Friction and heat buildup cause piercing blades to expand, reducing clearance, possibly to the point of blade interference. Therefore, in most applications, it is beneficial to maintain a wider gap at the guide blades.

The LXP 200 features a single guide blade, as this model does not experience problematic blade expansion to the degree described above.

Guide Blade to Piercing Blades Gap		
Model	Minimum	Maximum
200	0.005"	0.020"
300		
400	0.010"	0.025"
500		

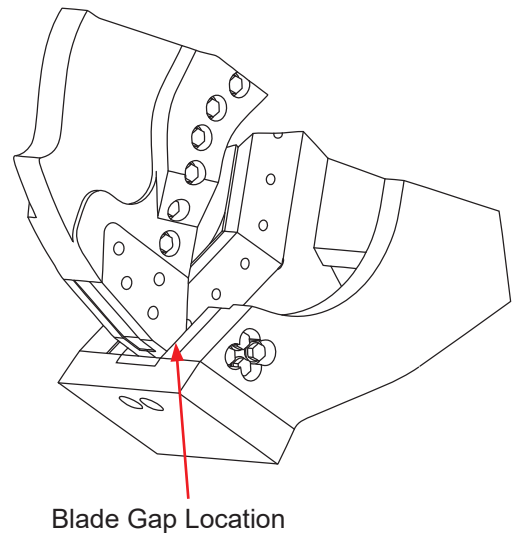

Shimming

Slowly close the jaw so the upper piercing blades begin to bypass the guide blades. Stop the jaw and check the gap between the guide blades and piercing blades. Cycle the jaw slowly, stopping at several points along the piercing blades to check the gap each time.

Shim the guide blades as needed to keep the gap within the tolerances listed in the Blade Gap table.

To install shims, loosen blade bolts and slide shims between the guide blade and guide blade seat. Retorque bolts and recheck the gap.

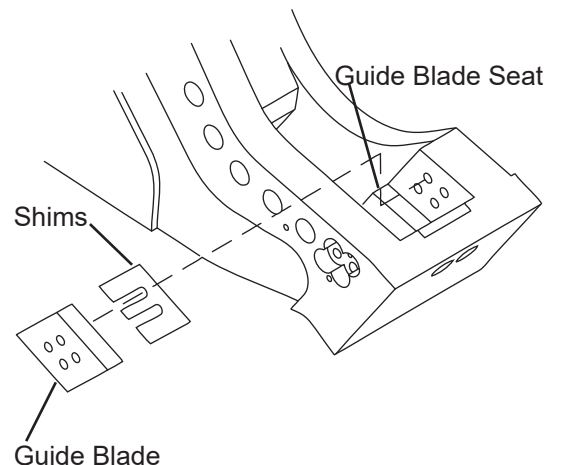

GUIDE BLADES

Rotation

Remove the blade bolts, guide blade and shims. Rotate the blade end-for-end or side-to-side; reinstall and torque bolts. Check gap; shim if required.

If the guide blade faces are excessively worn, the blades cannot be rotated. Excessively worn blades will have uneven surfaces that, when placed upon guide blade seat surfaces, will not be supported and will break, resulting in blade seat damage.

Replacement

Remove guide blade and shims. Install new guide blade with no shims. Check blade gap and shim as needed.

Adjustment Plates

Do not remove the guide blade adjustment plates from the lower jaw during routine blade rotation or replacement. These plates are custom-machined for each jaw set and need only be replaced when lost, damaged or extremely worn.

Inspect the top of the adjustment plate for burrs, nicks or other imperfections that may prevent proper seating of the guide blade and cause errant blade gap readings. Clean the adjustment plate as necessary. Inspect the blade seat for damage or imperfections and clean or repair as necessary.

Replacement plates can be ordered from your Genesis dealer or the Genesis parts department with the serial numbers of your processor and jaw set.

Offset dowel or fastener holes are located in each adjustment plate. When replacing adjustment plates, make sure these are aligned with the corresponding holes in the blade seat.

Do not grind on blade seat areas.

PRIMARY AND SECONDARY BLADES

Proper maintenance of the primary and secondary blades, or cutting blades, is required for optimal performance. Blade rotation extends blade life and improves cutting performance. Shimming to maintain blade tolerances helps prevent jamming. Dull blades make the excavator hydraulic system work harder and may cause structural damage to the processor.

Inspect blades every eight hours of operation. Re-torque loose bolts and replace broken bolts. Grind away dents or mushrooming of blade edges at the end of each day to prevent upper jaw deflection, excessive blade wear and undue stress to upper and lower jaws.

Rotate blades to use all four cutting edges. Always use Genesis-approved blades. Blades that do not meet Genesis specifications can cause major problems, and using them may void the warranty.

Before performing any blade maintenance, read, fully understand and follow these safety rules.

- Wear personal safety equipment including gloves, safety glasses, safety boots and proper clothing.
- Safe blade maintenance requires two people - one to steady the blade while the other loosens the bolts.
- Blades are heavy and may fall out of the blade seat if not adequately supported. Bystanders must stand clear.
- Never strike a blade with a hardened steel tool. The blade may fragment, creating sharp flying debris.

Removal

Loosen the bolts on one blade at a time, enough to loosen the blades.

If blades remain tight, insert a 7/16" drift pin into the through-hole on the lower jaw. Tap the drift pin with a hammer until the blade is loose.

Carefully remove bolts and blades.



PRIMARY AND SECONDARY BLADES

Adjustment Plates

Do not remove the adjustment plates from the lower jaw during routine blade rotation or replacement. These plates are custom-machined for each jaw set and need only be replaced when lost, damaged or extremely worn.

Inspect the top of each adjustment plate and seat for burrs, nicks or other imperfections that may prevent proper seating of the blades and cause errant blade gap readings. Clean the adjustment plates as necessary.

Replacement plates can be ordered from your Genesis dealer or the Genesis parts department with the serial numbers of your processor and jaw set.

Offset dowel or fastener holes are located in each adjustment plate. When replacing adjustment plates, make sure these are aligned with the corresponding holes in the blade seat.

Do not grind on blade seat areas.

Rotation

Rotate blades when the cutting edges are worn to a 1/8" (3 mm) radius.

Recommended rotation intervals are approximately 40-80 hours, depending on the material being processed. Thin materials may require shorter rotation intervals. Blades must be replaced when all four edges are worn to 1/8" (3 mm) radius.

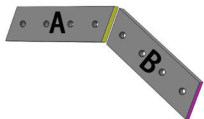
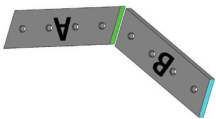
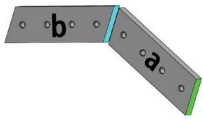
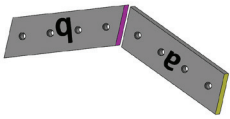
Original Blade Configuration	First Rotation Rotate both blades end-for-end	Second Rotation Rotate both blades front-to-back and exchange seat positions	Third Rotation Rotate both blades end-for-end
			

The following chart may be copied and used to track blade rotation.			
40 - 80 Hours	Date	Hour Meter	Performed By
Installed			
Rotation 1			
Rotation 2			
Rotation 3			

PRIMARY AND SECONDARY BLADES

Blade Gap

After each blade rotation, shim the lower blades to keep the gap within the specifications listed in the table below. Do not shim the upper blades. Use only Genesis shim kits.

Model	Minimum	Maximum
200	0.005"	0.015"
300		
400	0.010"	0.020"
500		

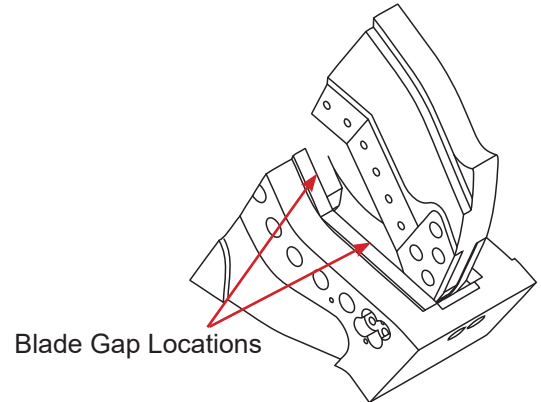

Blade Gap Measuring Procedure

Slowly close jaws until blades begin to bypass. Stop the jaw and check the gap with a feeler gauge.

Cycle the jaws slowly and continue checking the gap at several points along the entire length of the blades.

Note: The gap will be consistent along the entire length of the blades if they have been rotated and shimmed correctly.

If the blade gap exceeds the maximum listed on the table above, shim the lower blades. Blades must be replaced when shims exceed 0.060".

Shimming

Loosen blade bolts.

Install shims between the blades and adjustment plates as needed to bring into tolerance.

Torque bolts to spec and recheck the tolerances.

Do not use more than 0.060" of shims.

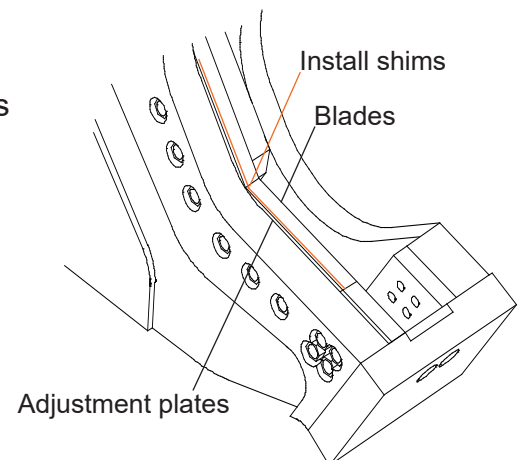

RAZOR BLADE

Check the razor blade for wear every eight hours of operation. Rotate when worn, using the edges in the sequence indicated by the illustration.

After rotation, check the gap between the razor blade and piercing blades. If the gap exceeds the maximum tolerance after new piercing blades have been installed, the razor blade must be replaced. Do not shim the razor blade.

Set-screws should be installed in unused bolt holes to prevent thread and hole damage. Replace set-screws when lost or damaged.

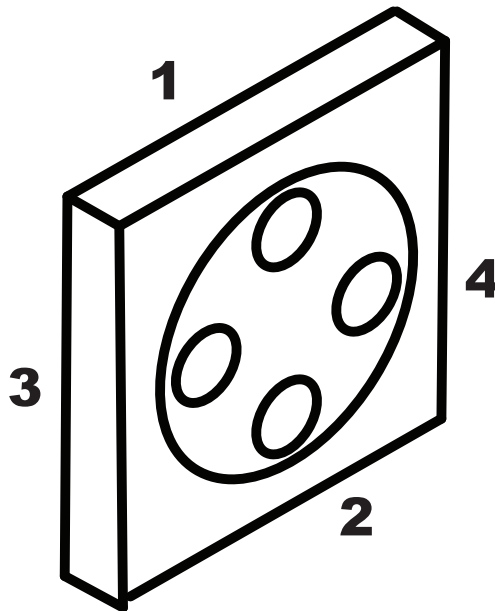

CRACKER JAW SET MAINTENANCE

Blade, tip and jaw maintenance greatly affects performance. To maximize performance and optimize the life of replaceable parts, follow all instructions for checks, adjustments and maintenance described in this section, at the intervals listed in the maintenance schedule in this manual.

Before performing maintenance, read, fully understand and follow these safety rules.

Wear personal safety equipment including gloves, safety glasses, safety boots and proper clothing.

Safe blade maintenance requires two people - one to steady the blade while the other loosens the bolts.

Blades are heavy and may fall out of the blade seat if not adequately supported. Bystanders must stand clear.

Never strike a blade with a hardened steel tool. The blade may fragment, creating sharp flying debris.

Concrete Cracking Tips

As teeth become worn, they need to be rotated, built-up or replaced.

To help customers determine and monitor how far processor teeth have worn from their original shape, Genesis has created tooth build-up templates.

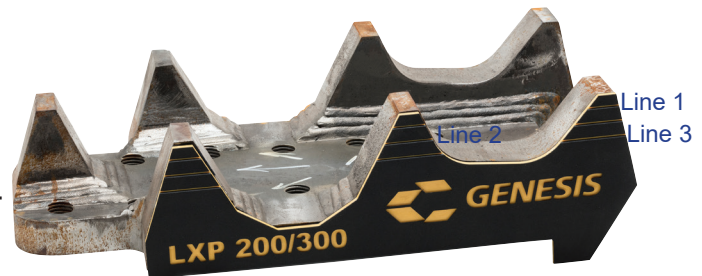

Each template is sized and formed to that tooth's original shape and features three lines that indicate wear level. Simply place the template over the tooth to determine the amount of wear and build-up required or if replacement is needed.

Line 1	½" wear - schedule maintenance to flip or rotate in jaw
Line 2	1" wear - flip, rotate in jaw or build up
Line 3	1½" wear - replace, if all points are worn on flippable teeth

See the following page for part numbers and contact your local Genesis dealer or the Genesis Parts Department to order.

CRACKER JAW SET MAINTENANCE

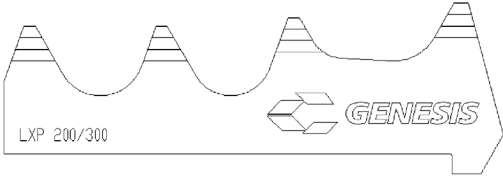
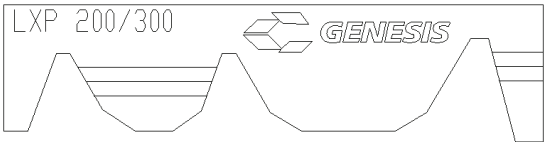
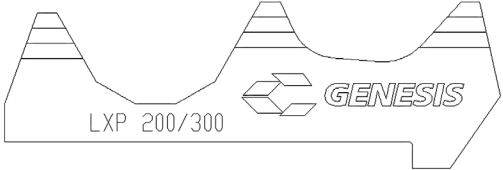
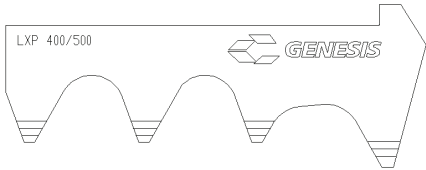
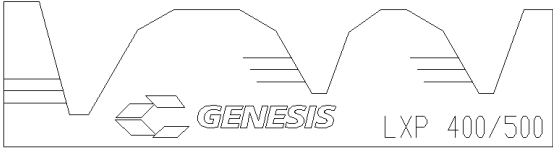
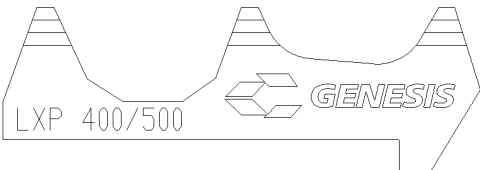
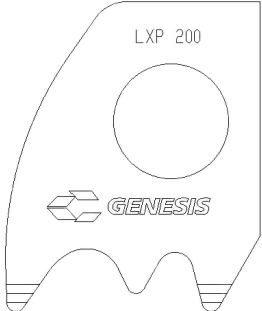
Model	Part Number	Template
200 & 300	9100582	
	9100583	
	9100584	
400 & 500	9100587	
	9100588	
	9100589	
200	9100852	
300 & 400	9100780	
500	9100853	

CRACKER JAW SET MAINTENANCE

At the end of each shift, check the condition of the concrete cracking tips. Replace any broken bolts, and retorquer loose bolts when cool.

Replace tips when teeth become severely rounded or flat. A more pointed tooth will process concrete more efficiently.

Cutting Blades

Proper maintenance of the cutting blades is required for optimal performance. Blade rotation extends blade life and improves cutting performance. Shimming to maintain blade tolerances helps prevent jamming.

Inspect blades every eight hours of operation. Re-torque loose bolts and replace broken bolts. Grind away dents or mushrooming of blade edges at the end of each day to prevent upper jaw deflection, excessive blade wear and undue stress to jaws.

Rotate blades to use all four cutting edges. Always use Genesis-approved blades. Blades that do not meet Genesis specifications can cause major problems, and using them may void the warranty.

Blade Removal

Loosen the bolts on one blade at a time, enough to loosen the blades.

Carefully remove the bolts and blades.

Blade Rotation

Rotate blades when the cutting edges are worn to a 1/8" (3mm) radius.

Recommended rotation intervals are approximately 40-80 hours, depending on the material being processed. Thin materials may require shorter rotation intervals. Blades must be replaced when all four edges are worn to 1/8" (3mm) radius.

The following chart may be copied and used to track blade rotation.

40 - 80 Hours	Date	Hour Meter	Performed By
Installed			
Rotation 1			
Rotation 2			
Rotation 3			

Blade Gap

After each blade rotation, shim lower blades to keep the gap within a range of 0.010" to 0.020". Do not shim the upper blades. Use only Genesis shim kits.

CRACKER JAW SET MAINTENANCE

Blade Gap Measuring Procedure

Slowly close jaws until blades begin to bypass. Stop the jaw and check the gap with a feeler gauge.

Cycle the jaws slowly and continue checking the gap at several points along the entire length of the blades.

Note: The gap will be consistent along the entire length of the blades if they have been rotated and shimmed correctly.

If blade gap exceeds the 0.020", shim lower blades. Blades must be replaced when shims exceed 0.060".

Shimming Procedure

Loosen blade bolts.

Install shims between blade and blade seat as needed to bring into tolerance.

Torque bolts to spec and recheck tolerances.

Do not use more than 0.060" of shims.

PULVERIZER JAW SET MAINTENANCE

Tooth and jaw maintenance greatly affects performance. To maximize performance and optimize the life of replaceable parts, follow all instructions for checks, adjustments and maintenance described in this section, at the intervals listed in the maintenance schedule in this manual.

Before performing maintenance, read, fully understand and follow these safety rules.

Wear personal safety equipment including gloves, safety glasses, safety boots and proper clothing.

Safe removal of pulverizing teeth requires two people - one to steady the tooth bed while the other loosens the bolts.

Tooth beds are heavy and may fall from the jaw if not adequately supported while bolts are being loosened. Bystanders must stand clear.

Never strike pulverizing teeth with a hardened steel tool. The tooth may fragment, creating sharp flying debris.

Pulverizing Teeth

At the end of each shift, check the condition of pulverizing teeth. Replace any broken bolts, and retorque loose bolts when cool.

Replace tooth bed when tips become severely rounded or flat. Dull teeth will process concrete less efficiently.

GENERAL WELDING GUIDELINES

Build-up and hard-surfacing are welding procedures that protect the parent material of the jaws and keep the blades in good adjustment. Build-up is the welding procedure that restores the jaws to their original shape. Building up the jaws helps protect the blades and increases the life of the attachment. Hard-surfacing is the welding material added over the parent material (or build-up material) to create a wear-resistant surface.

Welding should not be performed until the jaws are work-hardened. Work-hardening can take up to 80 hours. However, jaws must not wear lower than the height of a new blade. If either jaw wears down lower than blade height, immediately stop operating the attachment and perform build-up and hard-surfacing as described in the following pages of this manual.

When welding around blade seats or the piercing tip tang area, maintain the factory machined seat radius. If the rounded grooves are welded up, use a die grinder with a carbide tool to recut these areas to their original profile. Leaving a squared edge will eventually cause structural cracking. The radius provides a broader area to absorb structural stress.

Welding Ground Clamp

Disconnect all battery ground cables or shut off master battery switch, if equipped. Failure to do so may cause excavator electrical problems, including permanent damage to on-board computer systems.

Connect ground clamp as close as possible to the area being welded without allowing current to pass through the pivot group, cylinder pin, cylinder, swivel, motor, gearbox or slewing ring.

If you are welding on the lower jaw, connect weld clamp to the lower. If you are welding on the upper jaw, connect to the upper but not to the cylinder clevis. If needed, weld a piece of steel to the area for the grounding clamp and cut the piece off when welding is completed.

Welding Rules

Before you begin:

- Remove adjacent blades, as preheating and welding may cause blade damage.
- Wearing an approved respirator, grind the area to clean it, removing all existing hard-surfacing.
- Preheat area to 350° F (177° C). Maintain this temperature throughout the procedure. Do not exceed 450° F (232° C) interpass temperature.

During welding:

- Always grind and weld with the grain of the material.
- Peen each weld pass to relieve stress and harden the welds.
- Do not undercut the ends of the welds.
- Do not start or stop welds directly above a bolt hole or in the apex of the jaw.

After welding maintenance is complete:

- Cover the area with a heat blanket and allow it to cool slowly, approximately eight hours.
- Do not put the attachment into operation until the welds have been allowed to cool.

HARD-SURFACING

Do not apply hard-surfacing directly to the parent material as this could cause toe cracking, and the hard-surfacing will break away.

Procedure:

Follow the General Welding Guidelines and Rules.

Apply a single pass stringer bead pattern, with the grain, using E7018 electrode. Peen each pass.

Do not apply a stringer directly on the edge. Start the first pass 1/4" from the edge.

Stagger the ends of the stringer welds so they do not end in a straight line.

Cap each stringer bead with one pass of GenWire or GenRod to hard-surface. Do not apply more than two layers of hard-surfacing. Peen each pass.

Grind the ends of all stringer welds, with the grain to taper 1" to 1-1/2" (25 - 38 mm) to the parent material.

See the following pages for hard-surfacing illustrations and instructions specific to each area of the jaws.

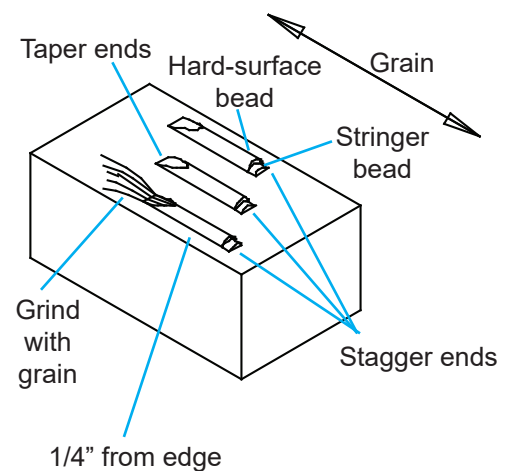

SHEAR JAW BUILD-UP

Procedure:

Follow the General Welding Guidelines and Rules.

Determine the area to build up, using a straight-edge or square. Jaws must not wear lower than the height of a new blade. Use a new blade to help determine build-up height for the jaw.

Build up the jaw to slightly higher than the original parent material profile with E7018. Apply single passes in each line with the grain of the steel, peening after each pass. Illustrations on the following page (for hard-surfacing patterns) indicate the grain of the steel.

Protection strips, or raised areas under or around blade seats, must be built up and maintained during build-up procedure using E7018 or equivalent. Illustrations on the following pages (for hard-surfacing patterns) indicate protection strips in blue.

These areas should be maintained between blade height and 0.010" lower than blade height. These areas protect the bottom unused edges of the blades as well as reduce the chance for material to catch on the bottom of the blade during jaw open functions, which causes blades to move in their seats.

Denting, deformation or build-up higher than blades in these areas may cause upper jaw deflection, excessive blade gaps, wear to blade faces and undue stress to upper and lower jaws.

After build-up is complete, grind material to be flush with a new blade.

Note: Closely monitor areas above guide blade bolt countersinks and below front two upper blade bolt countersinks. These are high-wear areas. If allowed to wear too far, parent material starts to fold into the countersinks, and it becomes time-consuming to clean out this area when access is needed for blade rotation and replacement.

SHEAR JAW HARD-SURFACING PATTERNS

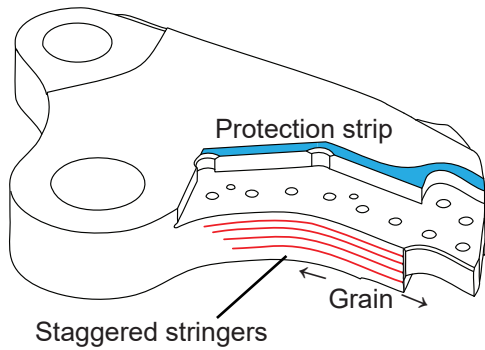

Upper Jaw

Single passes approximately 1" apart. Begin just behind the piercing blade seats and continue toward the throat. Use three to five stringers, depending on the shear model.

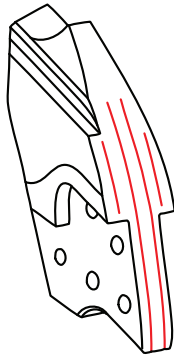

Upper Jaw Face

Single passes approximately 1" apart. Begin at the bottom of the upper face and continue approximately 2/3 up the front face.

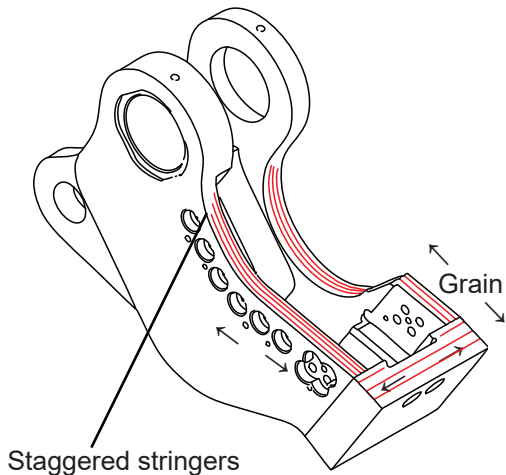

Lower Jaw

Single passes approximately 1" apart. Work across the top of the chin plate and along the lower jaw toward the throat. Use two to three stringers, depending on the shear model.

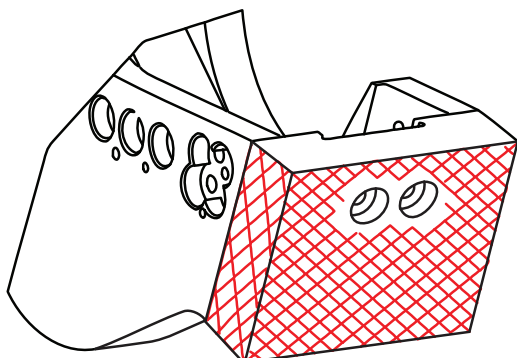

Lower Jaw Chin

Crosshatch the chin plate with stringer beads at 45° angles to form 1" squares.

CRACKER JAW WELDING MAINTENANCE

Build-Up

Procedure:

Follow the General Welding Guidelines and Rules.

Determine the area to build up, using a straight-edge or square. Do not allow jaws to wear to more than a 3/4" radius on edges of tool. Do not allow blade pocket to wear lower than the height of a new blade. Use a new blade to help determine build-up height for the pocket.

Build up the jaw to slightly higher than the original parent material profile with E7018. Apply single passes in each line with the grain of the steel, peening after each pass.

See drawings for grain, as indicated by arrows. Red lines indicate hard-surfacing pattern.

After build-up is complete, grind material flush with the flat surfaces of the tool or, if building up a blade seat, grind material flush with a new blade.

Hard-Surfacing Patterns

Single passes approximately 1" apart. Hard-surfacing patterns are indicated by red lines in the drawings.

Crosshatch may be used in place of straight stringers on flat areas of the jaws. **Do not crosshatch the curved areas of the jaws near the pivot.** Use only straight stringers on these areas.

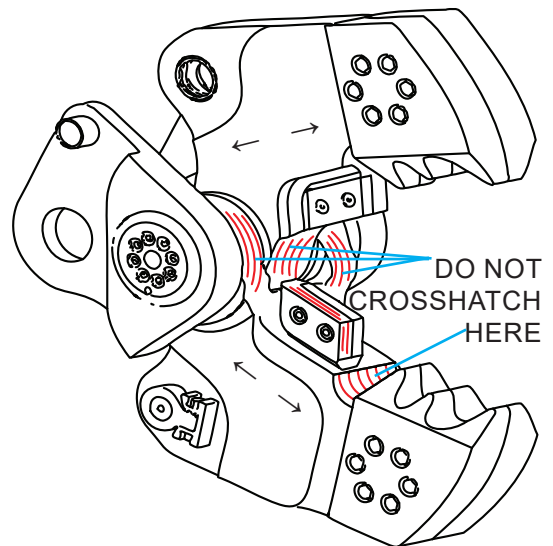

PULVERIZER JAW WELDING MAINTENANCE

Build-Up

Procedure:

Follow the General Welding Guidelines and Rules.

Determine the area to build up, using a straight-edge or square. Do not allow jaws to wear to more than a 3/4" radius on edges of tool.

Build up the jaw to slightly higher than the original parent material profile with E7018. Apply single passes in each line with the grain of the steel, peening after each pass.

See drawings for grain, as indicated by arrows.

After build-up is complete, grind material to be flush with the flat surfaces of the tool.

Hard-Surfacing Patterns

Single passes approximately 1" apart. Cover exposed faces with crosshatch pattern with stringer beads at 45° angles to form 1" squares.

Hard-surfacing patterns are indicated by red lines in the drawings.

Do not crosshatch the curved areas of the jaws near the pivot. Use only straight stringers on these areas.

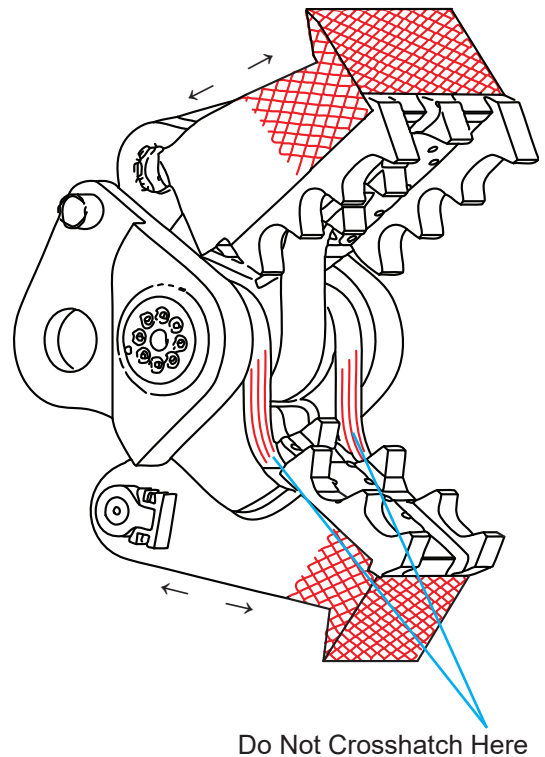

HYDRAULIC/ROTATION MAINTENANCE

Hydraulic Requirements

Operating the attachment below the recommended flow and/or pressure range will adversely affect performance and may damage the rotate motor.

Operating the attachment above the recommended flow and/or pressure range may damage the attachment and its hydraulic components.

Rotation Valve Input

For cooler and more efficient hydraulic system operation, set the input pressure as indicated in the chart. However, a rotation circuit rated for 2000-2500 PSI would be fine.

The maximum case drain measured at the attachment while rotating and cycling the jaws must never exceed 80 PSI or 40 PSI for axial piston motors. Pressure increases during cold-weather operation.

Rotation Valve Settings

When checking the crossover relief valve settings, put pressure gauges on both diagnostic ports. Stall attachment rotation in clockwise direction. Increase supply pressure until pressure at gauge on crossover stops rising. This is the crossover relief setting. Increase supply pressure to achieve approved crossover relief value. Repeat procedure in counter-clockwise direction. Then lower supply pressure back to approved value.

Note: with supply set at 2000 PSI, you should not hear oil bypassing in the crossover when stalling the rotation motor. If bypass is heard, either the crossover is set lower than 2200 PSI or the supply is set higher than 2200 PSI.

Model	Flow	Pressure
200	40-100 GPM	4500-5500 PSI 310-380 Bar
300	151-379 LPM	
400	80-200 GPM	
500	303-757 LPM	

Model	Flow	Pressure
200	3-5 GPM	1500-1700 PSI
300	11-19 LPM	103-117 Bar
400	7-11 GPM	1800-2000 PSI
500	26-42 LPM	125-138 Bar

Model	Flow	Supply Pressure	Crossover Relief
200	3-15 GPM	1700 PSI	2200 PSI 150 Bar
300	11-57 LPM	117 Bar	
400	8-15 GPM	1950 PSI	
500	30-57 LPM	134 Bar	

HYDRAULIC/ROTATION MAINTENANCE

GenFlow Regeneration Valve

Regeneration valves feature GenFlow adjustment cartridges to control the timing of the shift between speed and power modes. When the cartridge is properly set, the processor closes rapidly until it begins to cut. The valve shifts, slowing jaw close and increasing power. You may hear a squeal or hiss as this happens. The valve shifts back into speed mode after the cut is complete.

Cartridges are factory-set, turned out approximately five turns. This setting is appropriate for most applications. However, the cartridges may be custom-set if necessary. Adjust the cartridge on the master regeneration valve only; this will control the adjustment of the slave regeneration valve as well.

Regeneration valve adjustment is a two-person job. The ground crew must be in full view of the operator at all times and must stand clear of the processor jaws when cycling.

Regeneration Valve Adjustment

Check the cycle time when the hydraulic fluid is warmed up, timing from full open to full closed and back to full open.

To shift into power mode sooner, turn adjustment cartridge out (counter-clockwise). To shift into power mode later, turn in (clockwise).

Loosen the lock nut with a 9/16" socket.

Turn cartridge 180° (half-turn, 145 PSI) with a 5/16" allen-head socket.

Tighten lock nut.

Check the cycle time.

Repeat until the preferred balance of speed and power is met. Final adjustment may require less than a half-turn.

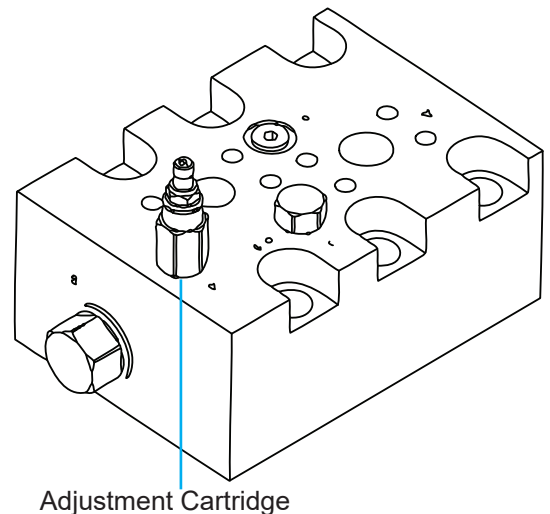

Shut off the excavator and disable the hydraulics per OEM instructions before adjusting the cartridge.

GENFLOW REGENERATION VALVE - HOW IT WORKS

Jaw Close in Regeneration: Oil that would normally leave the rod end of the cylinder and return to the tank is diverted to the bore end of the cylinder, increasing flow by approximately 50 percent and speeding up jaw close. In this mode, oil pressure on both rod and bore sides of the cylinder piston are basically equal and, although this speeds up the cylinder extend speed, it results in pressurized fluid on the rod side. If left in this mode, cylinder power is greatly reduced.

Jaw Close in Power Mode: To provide full power, when the upper jaw hits the material, the pressure rises. Once pressure exceeds the adjustment cartridge settings, it then shifts the rod oil back to the excavator hydraulic tank instead of the bore end of the cylinder. Pressure in the rod also drops, allowing full force from the bore pressure to be applied to the upper jaw for full cutting.

Jaw Open: Oil goes to the rod end of the cylinder, and bore oil goes back to the tank.

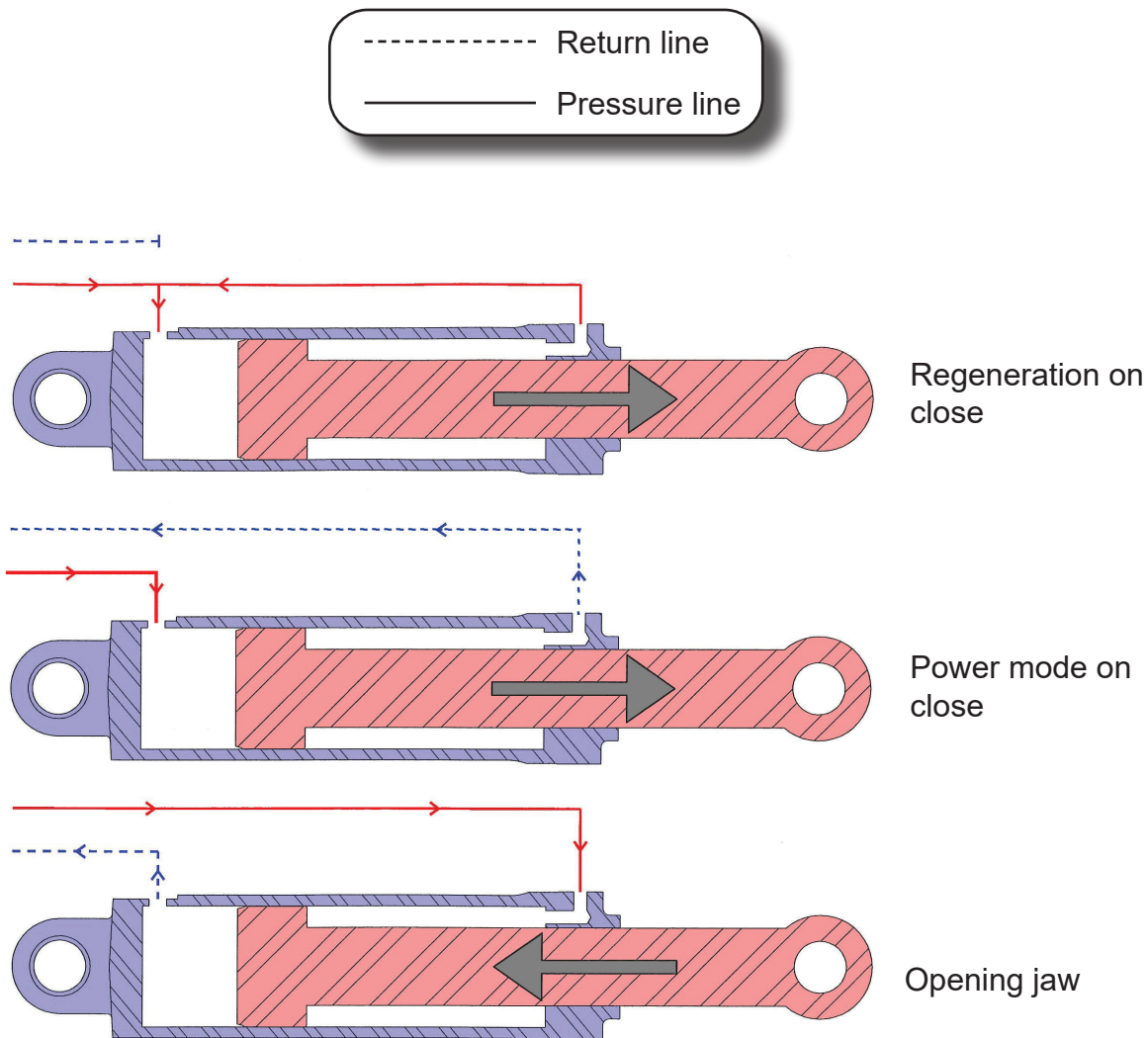

GENFLOW REGENERATION VALVE

6360004

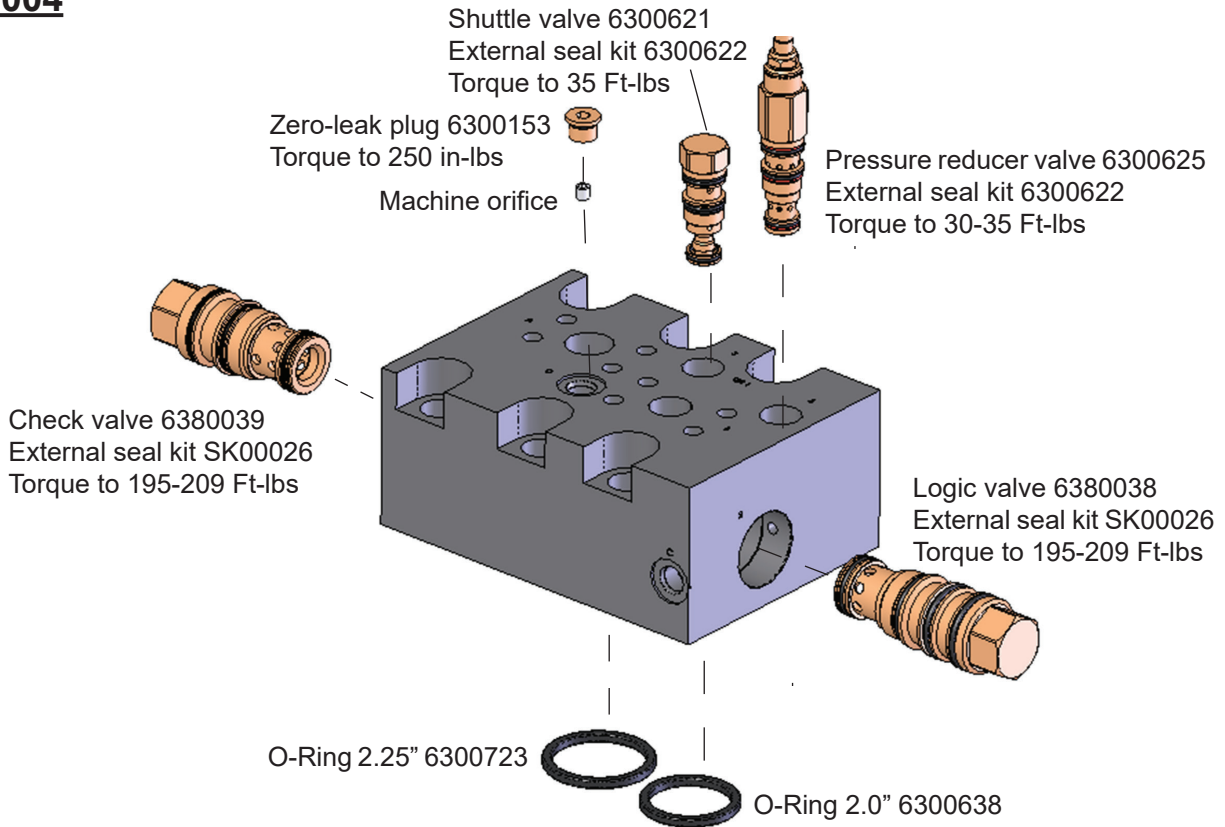

6300763

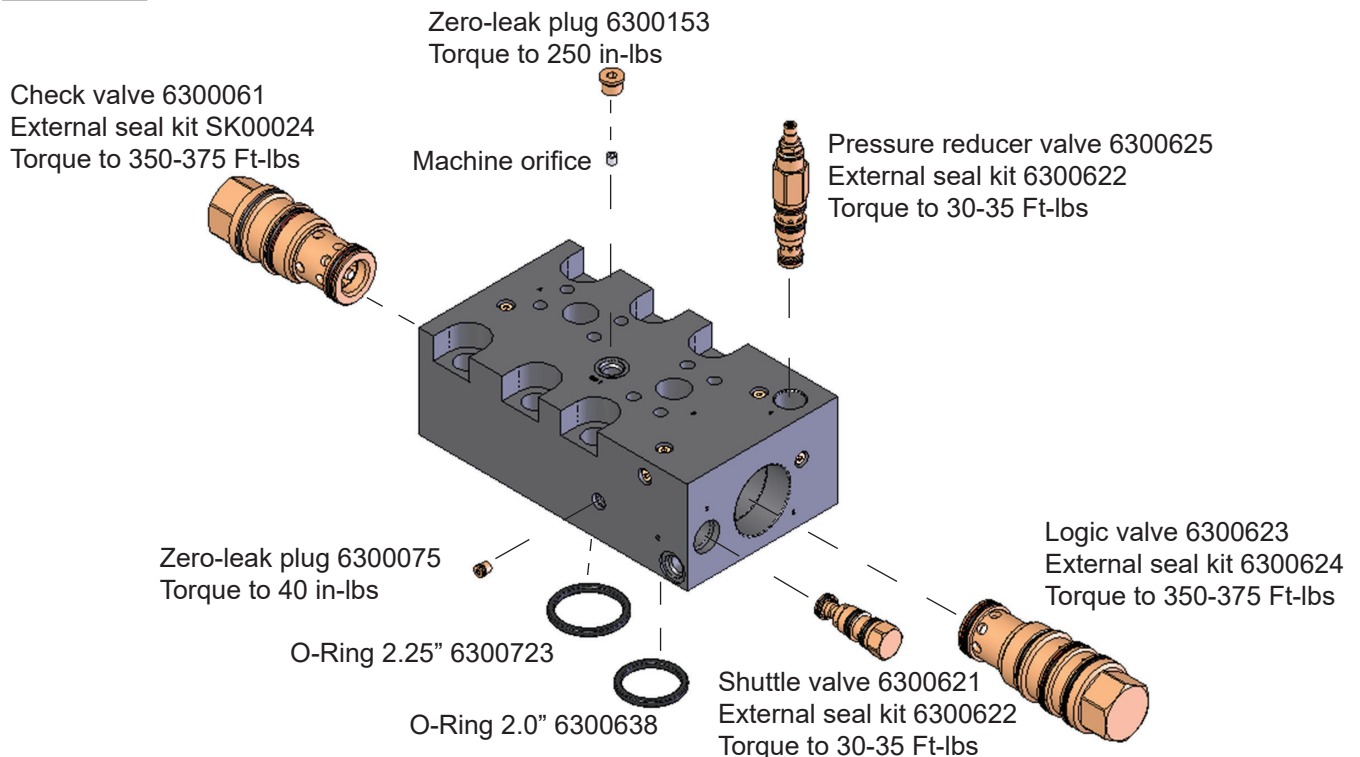

SLEWING RING MAINTENANCE

Visually check slewing ring (rotation bearing) bolts every eight hours of operation. Do not reuse or re-torque these bolts. Loose or broken bolts, along with the bolts on either side, must be immediately replaced.

The bolts that secure the slewing ring are critical for safe attachment operation. Improper torque may cause the bolts to fail and the attachment to break free, which may result in serious personal injury and equipment damage. Improper torque will also cause uneven slewing ring wear.

Rotating components must be greased daily. Grease fittings are located on the outside of the slewing ring and on the inside of the rotating head assembly. Grease locations are marked with decals.

Grease each fitting and then rotate the attachment two full rotations.

For normal conditions above 32°F (0°C), use a lithium-based, premium grade 2 extreme-pressure grease. For temperatures below 32°F, use a grade 0 grease. **Do not use grease containing Molybdenum (Moly).**



Genesis GLG-2[®] anti-wear, extreme-pressure lithium grease, PN 6302601, is recommended for all temperature conditions.



Stand clear when the attachment is being rotated. Always stay in clear view of the operator.

GEARBOX MAINTENANCE

Planetary Gearbox Lubrication

Proper lubrication is critical to ensure performance and long life of the gearbox. Change gearbox lubricant after the initial 50 hours of operation. Check gearbox lubricant every 250 hours. See table for recommended grades and lubricant change-out schedule based on climate.

Low Temp.	Grade	Change
5° F (-15° C)	SAE 80W-90W	500 hours or annually
-50° F (-45° C)	Synthetic ISO 150	1000 hours or two years

Gearbox Lube Change-out Procedure

1. Position the attachment so the gearbox is horizontally level at a convenient working height.
2. Remove the rotator access cover and place an oil drain pan under the gearbox drain plug.
3. Remove the bottom drain plug and top fill plug.
4. Once drained, replace the bottom drain plug.
5. Add 32 ounces (950 ml) of gearbox lubricant through the fill plug. Do not overfill.
6. Replace the fill and inspection plugs. Reinstall the access cover.
7. Properly dispose of the used lubricant.

ROTATION CIRCUIT

To meet diverse customer needs, Genesis offers two rotation valve options. They vary in mounting, function, factory-supplied and customer-supplied parts, and operating advantages.

Valves are factory-set and should not need adjustment. If you believe adjustment is necessary, contact the Genesis Service Department.

All rotation circuits use the same procedure for setting flow:

- Rotate processor, timing one complete revolution.
- Adjust corresponding flow control until revolution time is 14-16 seconds.
- Repeat in opposite direction.

Auxiliary Valve Rotation

Setting the crossover reliefs:

1. Increase supply pressure to the rotation valve to 2500 PSI.
2. Install pressure gauges on relief test ports.
3. Plug hoses at motor or secure the processor from rotating.
4. Pressurize the valve to rotate.
5. Adjust the corresponding relief valve to the pressure specified in the table for rotation valve settings.
6. Repeat for the other direction.
7. Reduce supply pressure to the pressure-reducer valve setting specified on the table for rotation valve settings.

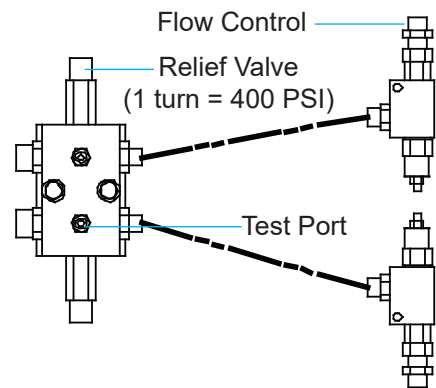

ROTATION CIRCUIT

Gear Pump Rotation

Setting the crossover reliefs:

1. Install a pressure gauge on the unloading valve, unplug the wires to the directional valve, and energize the valve on the unloading valve.
2. Adjust the unloading valve to 2500 PSI.
3. Reconnect the wires to the directional valve.
4. Plug hoses at motor or secure the processor from rotating.
5. Press the switch to rotate left or right.
6. Adjust the corresponding relief valve to the pressure specified in the table.
7. Repeat for the other direction.
8. Set the unloading valve before operating.

Setting the unloading valve:

1. Install a pressure gauge on the unloading valve, unplug the wires to the directional valve and press the switch to rotate left or right.
2. Adjust the unloading valve to the pressure specified in the table.
3. Plug the wires back into the directional valve.

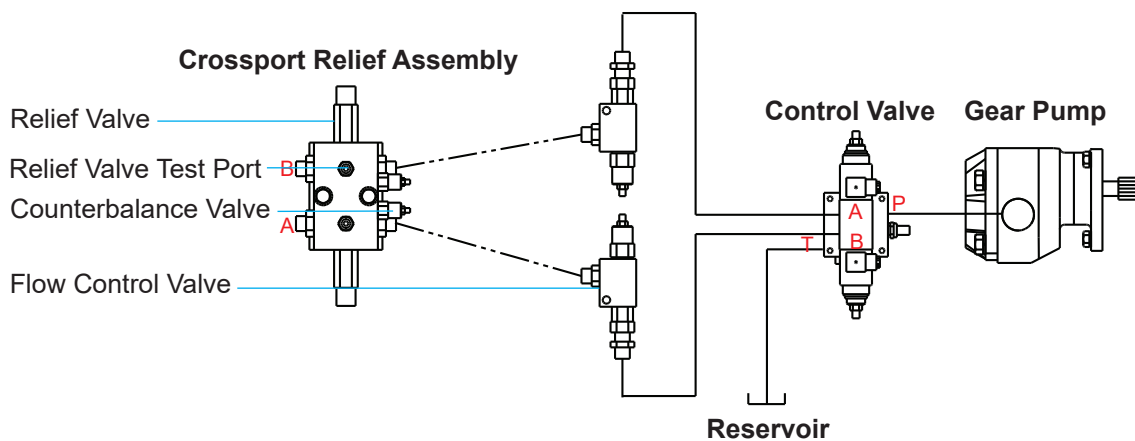

TROUBLE-SHOOTING GUIDE

Processor		
Symptom	Possible Cause	Possible Solution
Lacks power	Circuit not getting full pressure from excavator	Check hydraulic pressure at port block
	GenFlow cartridge needs adjustment	Make adjustments following procedure listed in this manual
	Processor cylinder or swivel bypass	Check for bypass and replace seals if needed
	Pilot check seals leaking	Replace seals
Poor cutting	Material size is beyond processor appetite range	Consult the factory
	Worn blades (shear jaw set)	Refer to Jaw and Blade Maintenance in this manual
	Excess blade gap (shear jaw set)	
	Pilot check seals leaking	Replace seals
Poor piercing (shear jaw set)	Piercing blades or razor blades are worn	Refer to Jaw and Blade Maintenance in this manual
Slow jaw cycle time	Genflow cartridge needs adjustment	Make adjustments following procedure listed in this manual
Material jamming	Excess blade gap	Refer to Jaw and Blade Maintenance in this manual
	Insufficient blade gap between piercing tips and guides	
	Worn blades (shear jaw set)	
	Worn piercing blades (shear jaw set)	
Slow jaw cycle in one direction	Excess back pressure on return side of cylinder	Check excavator main control valve and pilot check seals
Jaws drift closed or can be pushed closed	Excavator control valve	Check excavator main control valve
	Processor cylinder or swivel bypass	Check for bypass and replace seals if needed
	Pilot check seals leaking	Replace seals
	Bleed-down orifice plugged	Clean and replace orifice

TROUBLE-SHOOTING GUIDE

<u>Rotator</u>		
Symptom	Possible Cause	Possible Solution
Does not rotate	Blown fuse	Replace fuse
	Electrical problem	Test for 24V at plugs on directional valve while depressing foot switch
	Incorrect pressure settings	Set pressures
	Faulty components	Contact Genesis to replace valve
Does not rotate in one direction	No electrical power to one side	Test for 24V at plugs on directional valve while depressing foot switch
	Faulty directional control valve	Check if directional control valve shifts both ways while actuating foot switch in both directions
	Faulty cartridge	Contact Genesis to replace valve
Rotator chatters	Electrical short	Test for continuity through circuit
	Low supply flow	Back out flow controls
	Pressure settings too high	Set pressures
	Supply flow too high	Reduce flow from excavator control valve
	Power to both rotation solenoids at the same time	Test for 24V at plugs on directional valve while depressing foot switch
Rotates faster in one direction	One flow control cartridge set higher than the other	Set flow control
Rotates too fast or too slow	Flow control out of adjustment	Set flow control
Rotation speed changed from original setting	Jam nut loosened on rotation flow control valve	Check jam nuts on rotation flow control valve; set pressures
	Faulty cartridge (contamination)	Replace cartridge
	Faulty directional control valve	Replace valve
	Pressure set too low	Set pressures

TROUBLE-SHOOTING GUIDE

Lock-Pin		
Symptom	Possible Cause	Possible Solution
Lock-pin not operating	No electrical power	Test for 24V at plugs on lock-pin valve while depressing toggle switch
	Cover plate not removed	Remove cover plate
	Incorrect pressure setting	Set pressure on lock-pin valve
	Lock-pin control valve not shifting	Replace with Genesis replacement valve
	Tool misalignment	Move tool to correct alignment
	Processor cylinder not dead-headed open	Dead-head processor cylinder open and hold while depressing toggle switch
Lock-pin won't retract	Hoses between lock-pin cylinder and valve connected incorrectly	Verify that hoses are routed to factory-specified ports on cylinder, swivel and control valve
	Swivel leaking internally	Test passes on swivel for bypass and repair if faulty

WARRANTY

Claim Procedure

Notify the Genesis Service Department of the potential warranty claim prior to making the repair. Digital pictures are very helpful for diagnosing problems and recommending repairs.

Contact the Genesis Service Department before making alterations, changes or repairs to any component that is going to be considered for warranty. Not doing so will void all Genesis warranty consideration.

The Genesis Service Department will issue an authorization number to track the repair costs, outgoing parts, and/or defective parts returning to the factory.

Replacement parts must be ordered using a purchase order number. Shipping is standard ground. Overnight shipping is available by request, and Genesis will not cover the shipping charge.

When the repair is complete, submit an invoice to the Genesis Service Department within 30 days. Include itemized internal labor reporting, parts lists and invoices for outside contractors. Reference the authorization number on all invoices.

When returning parts for warranty consideration, include a copy of any related Genesis paperwork along with any other necessary documentation to ensure proper processing and credit. The Genesis Service Department will provide the necessary forms.

Your account will be credited when the warranty claim is accepted.

Blade Warranty

Standard warranty on blades will only be considered on the first edge, and wear on the edge must be 1/8" radius or less. Genesis does not warranty cutting blades that are cracked or broken from top to bottom (perpendicular to the long edge of the blade). Genesis also does not cover fasteners, the labor to replace wear components or collateral damage, such as blade seats, from broken blades, the piercing blade tang or adjustment plates.

Please direct any questions to the Genesis Service Department: 715-395-5252

PARTS ORDER POLICY AND PROCEDURE

Parts Orders Should Include

- Purchase order number
- Model and serial number of attachment
- Part number and quantity needed
- Shipping and billing address
- Method of shipment or required delivery date

Placing Orders

Orders may be placed by phone or e-mail. To e-mail an order, use the form on the following page or your purchase order form. Contact information is located at the front of this manual.

Part Numbers

Part numbers are listed in a separate Parts Manual or, if included, the Parts section of this manual. Contact the Genesis Parts Department with questions regarding part numbers, availability and pricing.

Shipping

All orders will be shipped best way surface unless an alternate shipping method is requested. Shipping charges are not included in the purchase price of parts.

Invoices

All invoices are due upon receipt. Any accounts with invoices open beyond 60 days are subject to review and may be placed on C.O.D. status without further notice.

Returns

Many unused Genesis parts may be returned with proper documentation. Return shipping is the responsibility of the purchaser. Credit will be issued upon return, less a 25% restocking fee. Documentation is required for credit of returned parts. Contact the Genesis Service Department at 715-395-5252 for an RGA (Return Goods Authorization) number and form. An RGA must accompany every return. Items shipped without an RGA may be returned to sender.

Warranty Returns

All parts returned to Genesis for warranty consideration must be returned with a completed RGA (Return Goods Authorization) provided by the Genesis Service Department. The form needs to be completed in its entirety, including any additional information requested by the Service Department. Return shipping is the responsibility of the sender and will be credited upon claim approval. A determination to accept or deny the claim will be made based upon the information available to Genesis. Warranty on purchased parts other than wear components is 6 months. Genesis does not cover labor costs to replace purchased parts replaced under warranty. There is no warranty period on wear parts or components.

PARTS

The following pages contain illustrations and parts lists for all LXP models. These photos and generalized drawings identify major components and may not be identical in fine detail to a particular processor.

The parts lists included here are intended to aid in operation and maintenance. If further information is required, contact the Genesis Parts Department for a breakdown and parts list specific to your processor model and serial number.

Part numbers listed are those currently used. These may differ from the part numbers of the components originally installed in your processor. To ensure use of the correct internal components, always indicate your processor's serial number when ordering parts.

PARTS

Third-Member Mount Upper Head

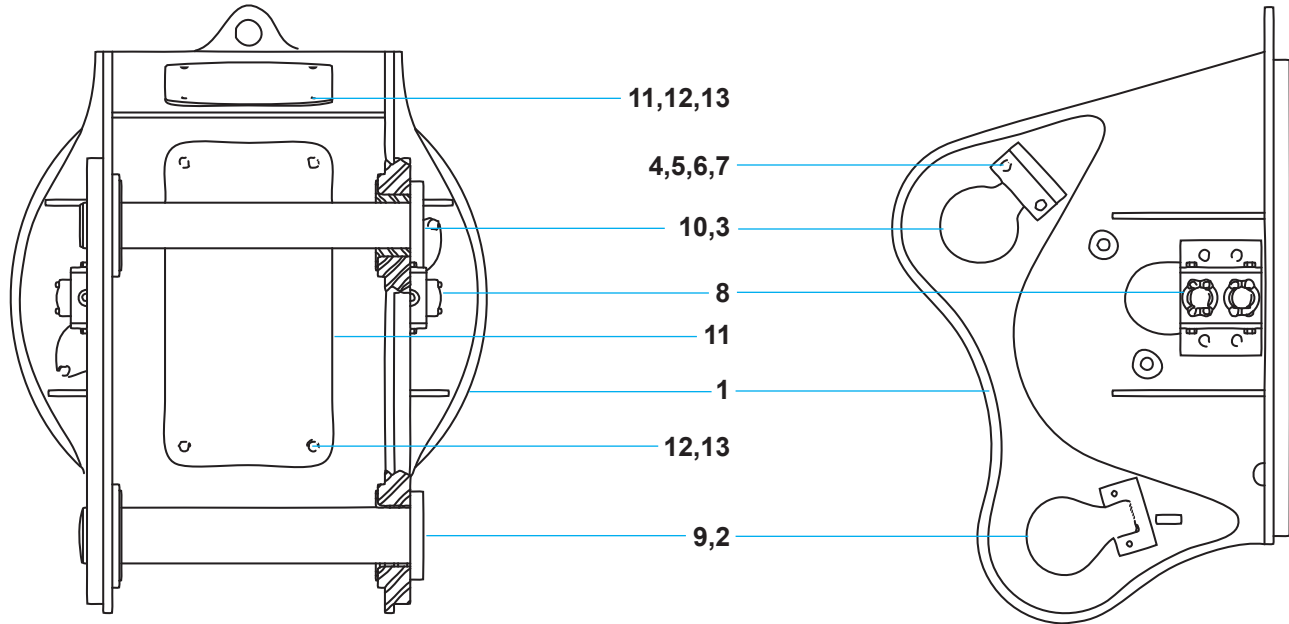

Item	Description
1	Upper Head
2	Stick Pin
3	Spacer Sleeves, where used
4	Pin Keeper
5	Strap
6	Bolt (Hex Head Capscrew)
7	Lock Washer
8	Port Block Assembly
9	Bearings and/or Spacer Sleeves, where used
10	Cylinder Link Pin
11	Inspection/Access Cover
12	Bolt (Hex Head Capscrew)
13	Flat Washer

Custom parts - call the Genesis Parts Department for part numbers specific to your serial number.

PARTS

Second-Member Mount Upper Head

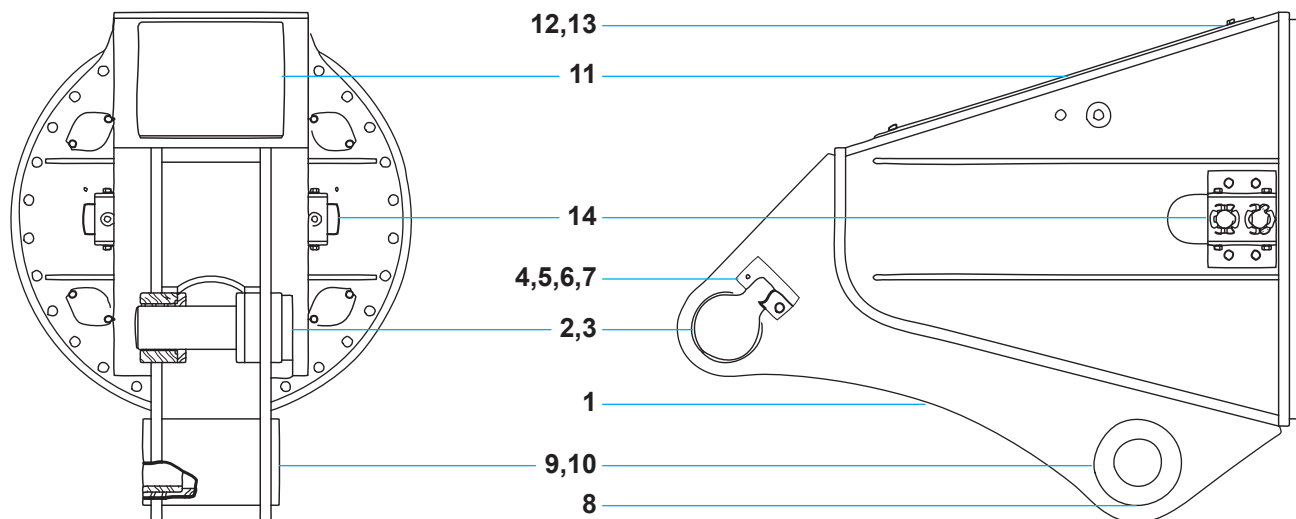

(Boom Pin provided by excavator OEM)

Item	Description
1	Upper Head
2	Cylinder Pin
3	Spacer Sleeves
4	Pin Keeper
5	Strap
6	Bolt (hex head capscrew)
7	Lock Washer
8	Grease Fitting
9	Boom Bearings
10	Machine Bearings, where used
11	Inspection/Access Cover
12	Bolt (hex head capscrew)
13	Flat Washer
14	Port Block Assembly

Custom parts - call the Genesis Parts Department for part numbers specific to your serial number.

PARTS

Multi-Processor Body

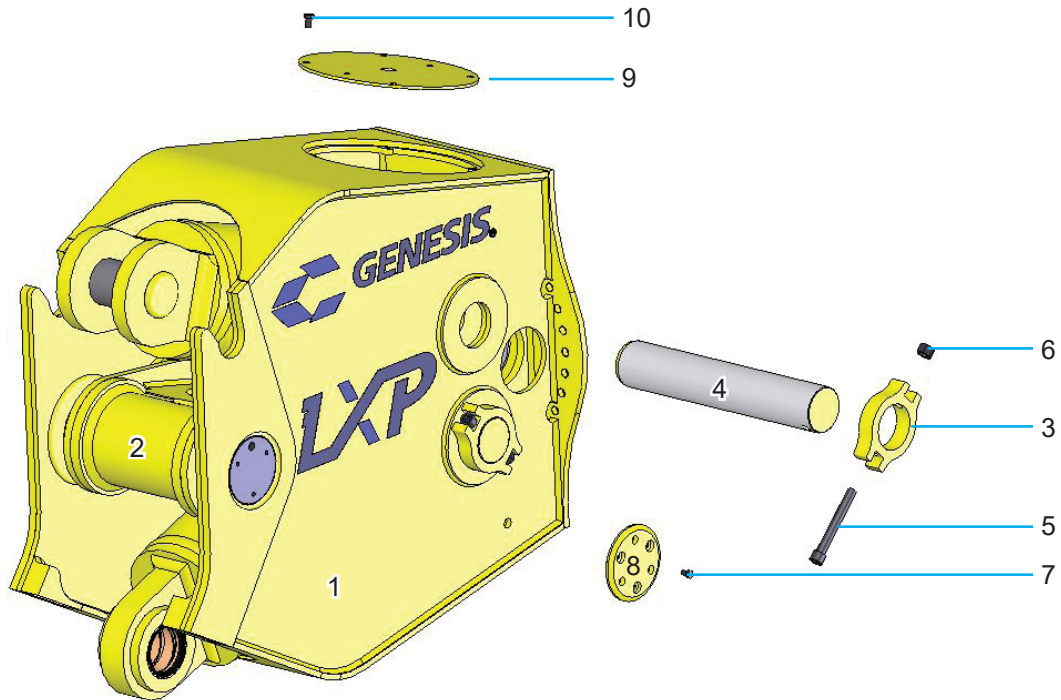

Item	Description	Qty	200	300	400	500
1	Body	1	3500842	3500288	3500608	3500591
2	Lock Pin Assembly	1	6300841	6300841	1200191	1200191
3	Rear Pin Keeper	2	3500831	3500309	3500634	3500022
4	Rear Cylinder Pin	2	3500837	3500342	3500636	3500607
5	Keeper Bolt**	2	F0616150	F0620150	F0620180	F0620180
6	Keeper Nut	2	F1016200	F1020250	F1020250	F1020250
7	Lock Pin Bolt***	*	F0110016 *6	F0110016 *6	F0112030 *8	F0112030 *8
8	Safety Plate	2	3500321	3500321	3500113	3500113
9	Cover	2	3500015	3500015	3500015	3500015
10	Cover Bolt	8	F0112020	F0112020	F0112020	F0112020

** LXP 200 M16 x 2 x 150, LXP 300 M20 x 2.5 x 150, LXP 400 & 500 M20 x 2.5 x 180

*** LXP 200 & 300 M10 x 1.5 x 16, LXP 400 & 500 M12 x 1.75 x 30

PARTS

Shear Jaw Set Pivot Group

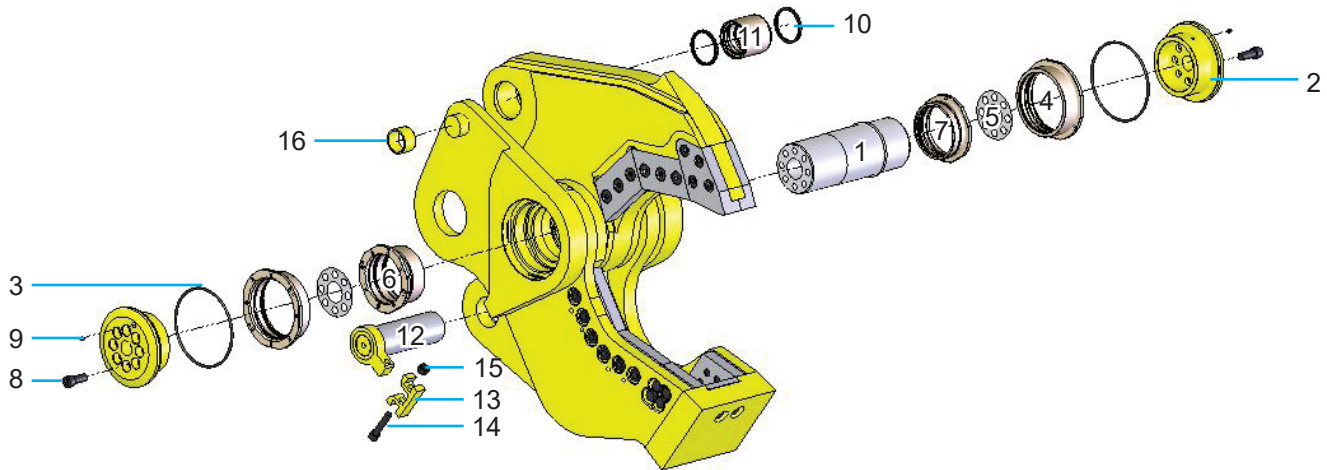

Item	Description	Qty	200	300	400	500
1	Main Shaft	1	3500811	3500198	3500034	3500034
2	End Cap	2	3500810	3500269	3500026	3500026
3	O-Ring	2	S0190369	S0190449	S0190454	S0190454
4	Quick Plate Bushing	2	3500813	3500267	3500029	3500029
5	Main Shaft Shim Set	2	3500846	3500360	3500032	3500032
6	RH Bushing	1	3500814	3500270	3500027	3500027
7	LH Bushing	1	3500817	3500268	3500028	3500028
8	End Cap Bolt**	*	F0627050 *12	F0624060 *16	F0630060 *16	F0630060 *16
9	Grease Fitting	6	6200002	6200002	6200002	6200002
10	Wiper Seal	2	S0800002	6300880	S0800001	6300805
11	Bushing	1	6100349	6300877	6100343	6300804
12	Lower Jaw/Cylinder Pin	1	3500227	3500366	3500632	3500035
13	Pin Keeper	1	3500829	3500350	3500350	3500266
14	PK Bolt***	1	F0616090	F0620100	F0620100	F0620130
15	PK Nut	1	F1016200	F1020250	F1020250	F1020250
16	Quick Plate Trunion Bushing	2	3500886	3500359	3500190	3500190

** LXP 200 M27 x 3 x 50, LXP 300 M24 x 3 x 60, LXP 400 & 500 M30 x 3.5 x 60

*** LXP 200 M16 x 2 x 90, LXP 300 & 400 M20 x 2.5 x 100, LXP 500 M20 x 2.5 x 130

PARTS

Concrete Cracker Jaw Set Pivot Group

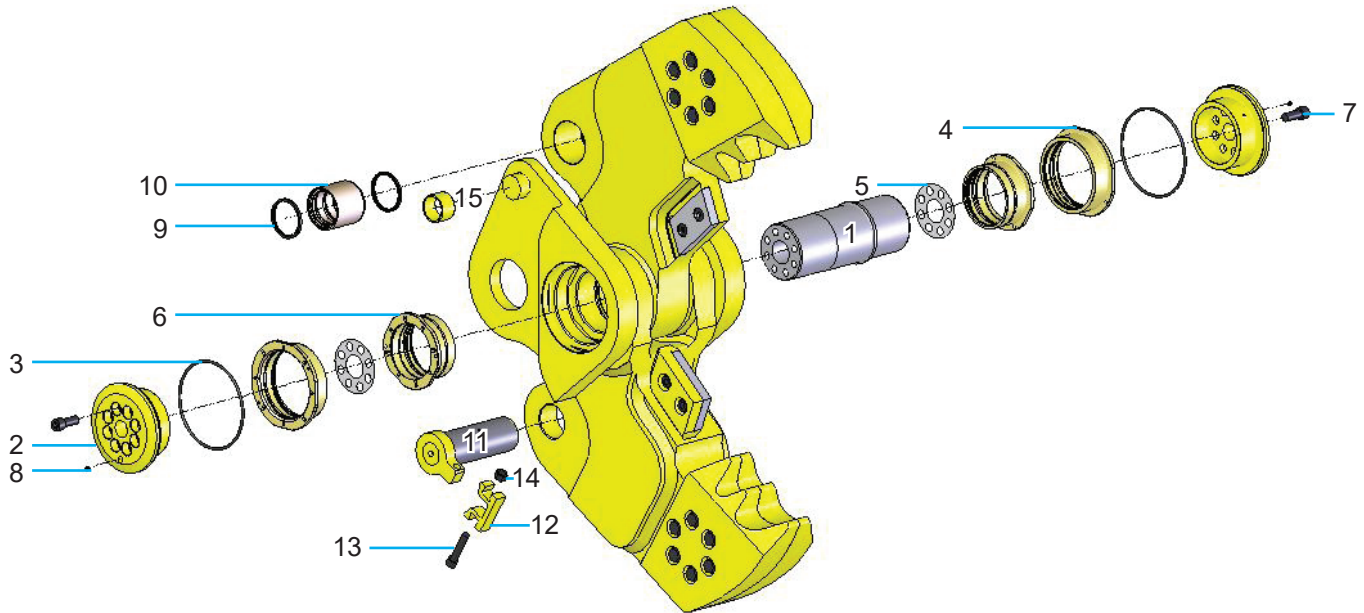

Item	Description	Qty	200	300	400	500
1	Main Shaft	1	3500840	3500376	3500115	3500115
2	End Cap	2	3500810	3500269	3500026	3500026
3	O-Ring	2	S0190369	S0190449	S0190454	S0190454
4	Quick Plate Bushing	2	3500813	3500267	3500029	3500029
5	Main Shaft Shim Set	2	3500846	3500360	3500032	3500032
6	Main Shaft Bushings	2	3500817	3500399	3500118	3500118
7	End Cap Bolt**	*	F0627050 *12	F0624060 *16	F0630060 *16	F0630060 *16
8	Grease Fitting	4	6200002	6200002	6200002	6200002
9	Wiper Seal	2	S0800002	6300880	S0800001	6300805
10	Bushing	1	6100349	6300877	6100343	6300804
11	Lower Jaw/Cylinder Pin	1	3501043	3500434	3500696	3500538
12	Pin Keeper	1	3500829	3500350	3500350	1102487
13	PK Bolt***	1	F0616090	F0620100	F0620100	F0620130
14	PK Nut	1	F1016200	F1020250	F1020250	F1020250
15	Quick Plate Trunion Bushing	2	3500886	3500359	3500190	3500190

** LXP 200 M27 x 3 x 50, LXP 300 M24 x 3 x 60, LXP 400 & 500 M30 x 3.5 x 60

*** LXP 200 M16 x 2 x 90, LXP 300 & 400 M20 x 2.5 x 100, LXP 500 M20 x 2.5 x 130

PARTS

Concrete Pulverizer Jaw Set Pivot Group

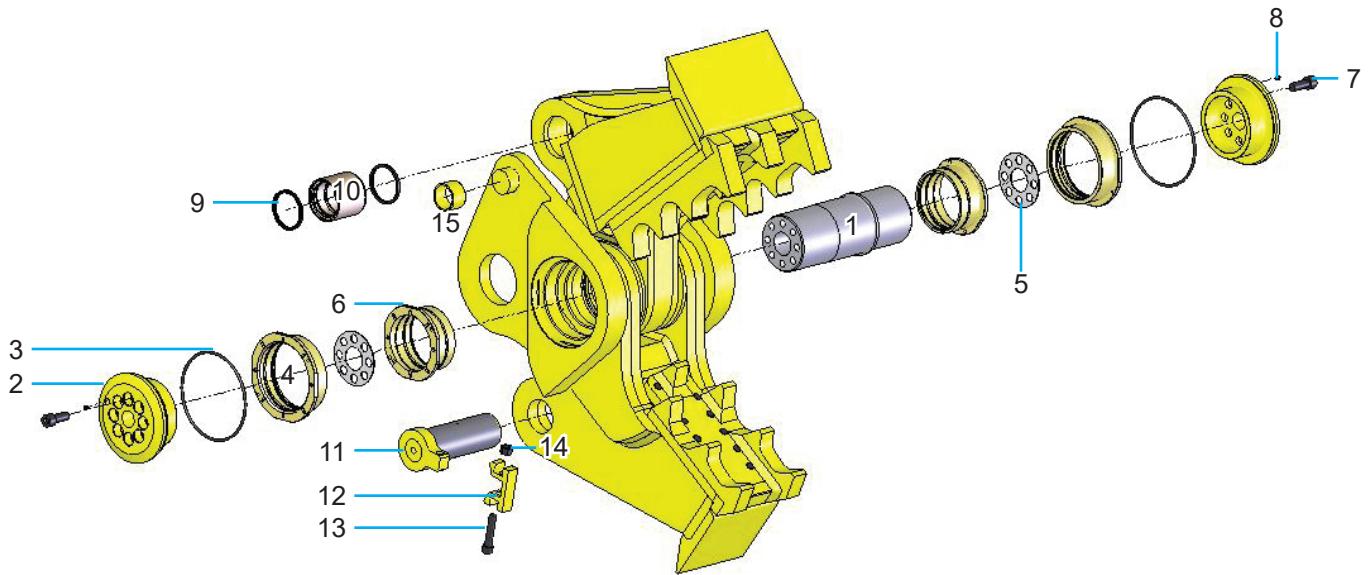

Item	Description	Qty	200	300	400	500
1	Main Shaft	1	3500840	3500376	3500115	3500115
2	End Cap	2	3500810	3500269	3500026	3500026
3	O-Ring	2	S0190369	S0190449	S0190454	S0190454
4	Quick Plate Bushing	2	3500813	3500267	3500029	3500029
5	Main Shaft Shim Set	2	3500846	3500360	3500032	3500032
6	Main Shaft Bushings	2	3500817	3500399	3500118	3500118
7	End Cap Bolt**	*	F0627050 *12	F0624060 *16	F0630060 *16	F0630060 *16
8	Grease Fitting	4	6200002	6200002	6200002	6200002
9	Wiper Seal	2	S0800002	6300880	S0800001	6300805
10	Bushing	1	6100349	6300877	6100343	6300804
11	Lower Jaw/Cylinder Pin	1	3500920	3500434	3500665	3500182
12	Pin Keeper	1	3500829	3500350	3500350	1102487
13	PK Bolt***	1	F0616090	F0620100	F0620100	F0620130
14	PK Nut	1	F1016200	F1020250	F1020250	F1020250
15	Quick Plate Trunion Bushing	2	3500886	3500359	3500190	3500190

** LXP 200 M27 x 3 x 50, LXP 300 M24 x 3 x 60, LXP 400 & 500 M30 x 3.5 x 60

*** LXP 200 M16 x 2 x 90, LXP 300 & 400 M20 x 2.5 x 100, LXP 500 M20 x 2.5 x 130

PARTS

Hydraulics

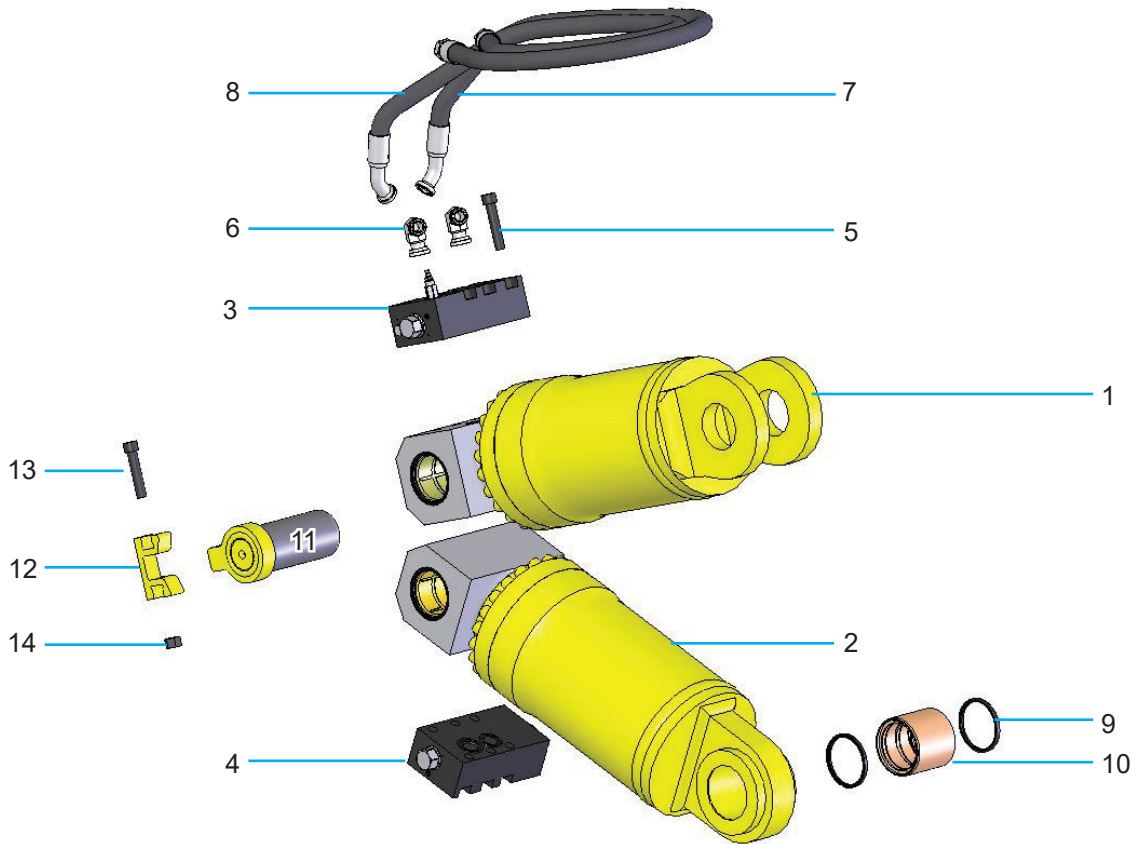

Item	Description	Qty	200	300	400	500
1	Cylinder	1	6350013	6300839	6350007	6300755
2	Cylinder	1	6350012	6300840	6350006	6300772
3	Regeneration Valve, Master	1	6360004	6360004	6300763	6300763
4	Regeneration Valve, Slave	1	6360005	6360005	6300773	6300773
5	Regen Bolts M20 x 2.5 x 100	12	F0620100	F0620100	F0620100	F0620100
6	Adapter	4	6310004	6310004	6310004	6310004
7	Hose	2	5300263	5300025	5300173	5300019
8	Hose	2	5300262	5300026	5300174	5300021
9	Wiper Seal	2	S0800002	6300880	S0800001	6300805
10	Mach Bearing	1	6100349	6300877	6100343	6300804
11	Pin	2	3500836	3500345	3500637	3500020
12	Pin Keeper	2	3500829	3500350	3500350	1102487
13	PK Bolt*	2	F0616150	F0620100	F0620100	F0620130
14	PK Nut	2	F1016200	F1020250	F1020250	F1020250

* LXP 200 M16 x 2 x 150, LXP 300 & 400 M20 x 2.5 x 100, LXP 500 M20 x 2.5 x 130

PARTS

Shear Jaw Set

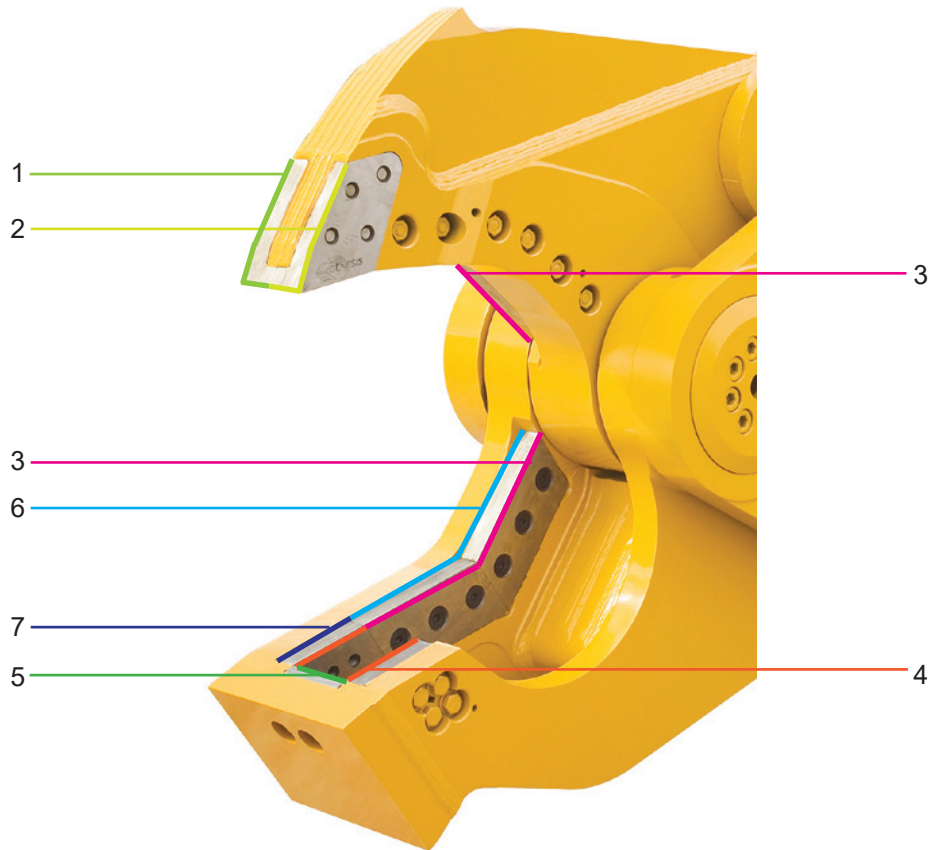

Item	Description	Qty	200	300	400	500
1	RH Tip Blade	1	4500394	1103538	1103538	1103538
2	LH Tip Blade	1	4500395	1103539	1103539	1103539
3	Cutting Blades	4	4500397 (upper) 4500396 (lower)	1103534	1103536	1103536
4	Guide Blades	2	4500398 (qty 1)	1103540	1103540	1103540
5	Razor Blade	1	4500399	1101955	1101955	1101955
6	Blade Shim Set	2	4500464	3500415	1104652	1104652
7	Guide Shim Set	1	4500470	1103660	1103660	1103660

PARTS

Concrete Cracker Jaw Set

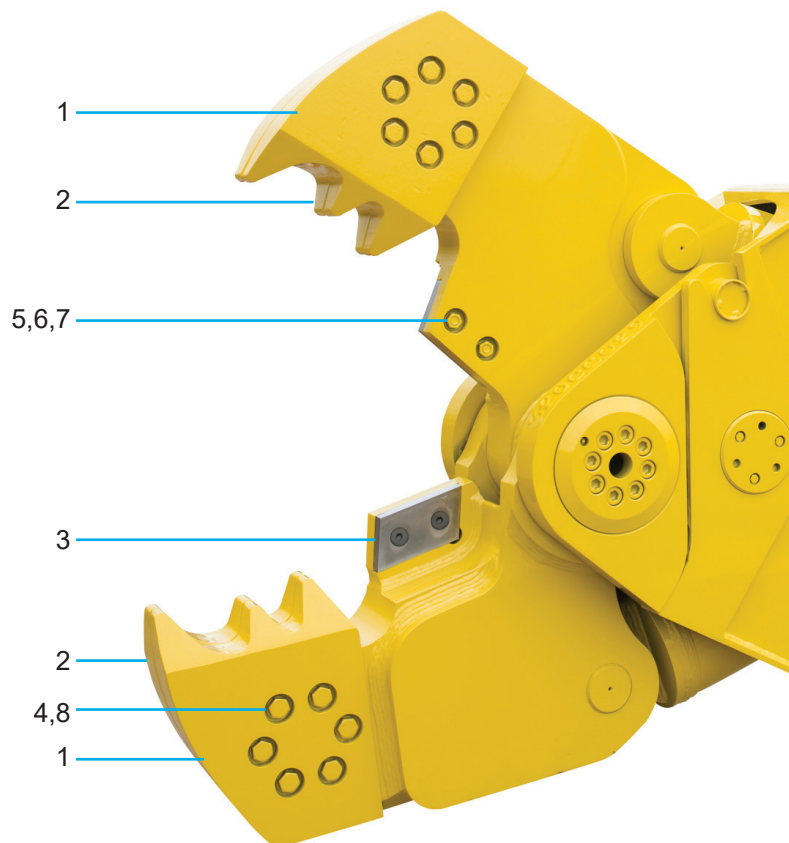

Item	Description	Qty	200	300	400	500
1	LH Tip	2	3501041	3500574	3500574	3500560
2	RH Tip	2	3501040	3500573	3500573	3500559
3	Cutting Blade	2	4500397	4500397	4500396	4500396
4	Tip Bolt	24	F0120045*	F0124065*	F0124060*	F0124065*
5	Blade Bolt	4	F0575250**	F0575250**	F0575275**	F0575250**
6	Hex Nut	4	F0907510	F0907510	F0907510	F0907510
7	Flat Washer	4	F1300075	F1300075	F1300075	F1300075
8	Flat Washer	24	n/a	F1202444	F1202444	F1202444

* LXP 200 M20 x 2.5 x 45, LXP 300 M24 x 3 x 65, LXP 400 M24 x 3 x 60, LXP 500 M24 x 3 x 65

** LXP 200 & 300 ¾ - 10 x 2½, LXP 400 & 500 ¾ - 10 x 2¾

PARTS

Concrete Pulverizer Jaw Set

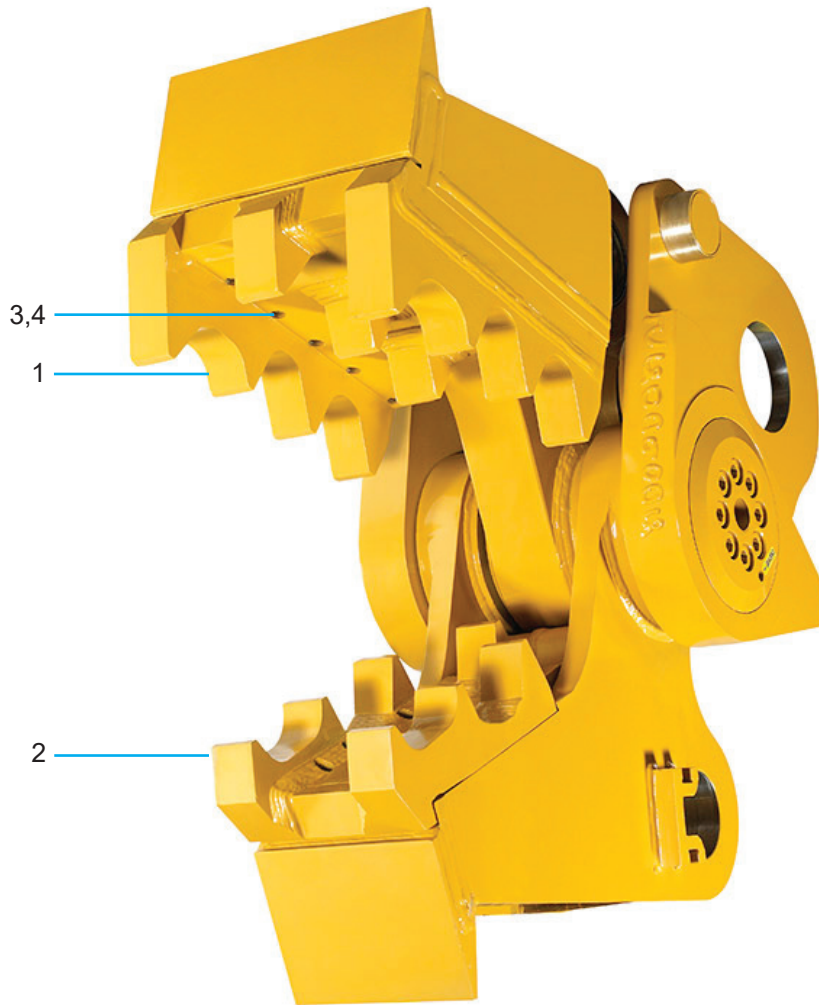

Item	Description	Qty	200 & 300	400 & 500
1	Upper Tooth Bed	1	3500815	3500780
2	Lower Tooth Bed	1	3500816	3500781
3	Bolt*	24	F0124050	F0130070
4	Flat Washer	24	F1202444	F1203056

* LXP 200 & 300 M24 x 3 x 50, LXP 400 & 500 M30 x 3.5 x 70

PARTS

Rotation Drive System LXP 200/300

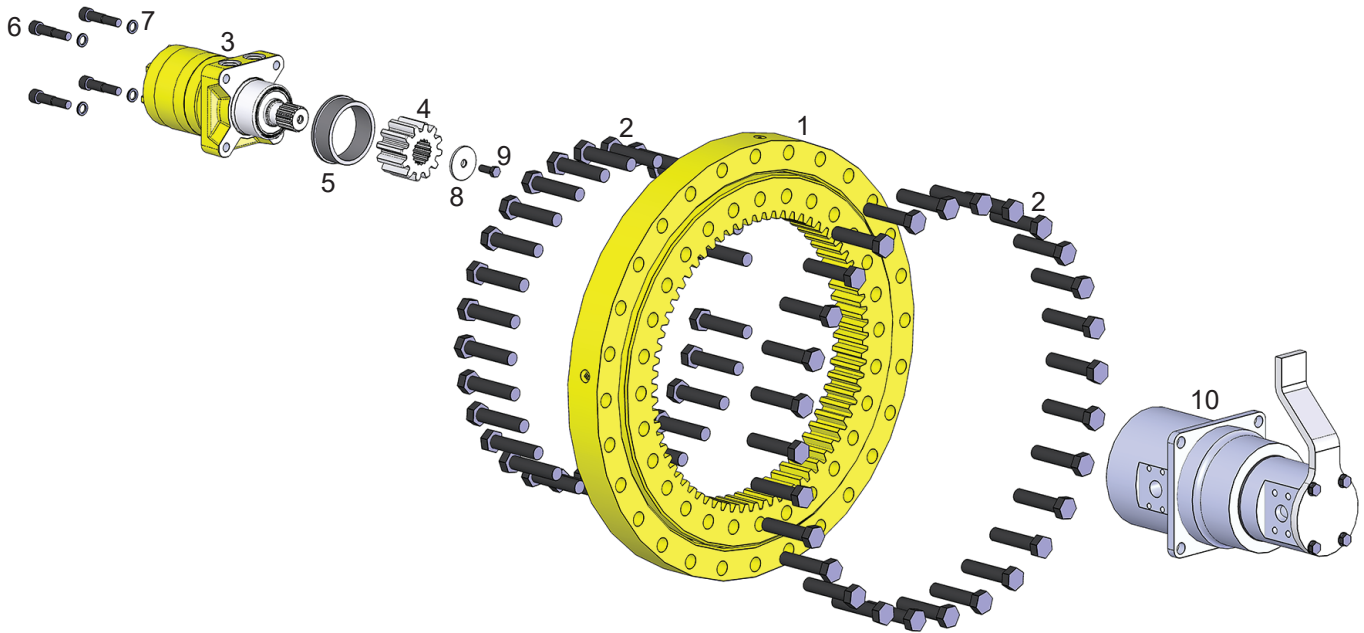

Item	Qty	Part Number	
		LXP 200 & 300	Description
1	1	6100092	Bearing Slewing
2	66	F0120100	Hex Head Capscrew M20 x 2.50 x 100
3	1	6380084	Motor
4	1	3101225	Pinion
5	1	1107014	Mach Spacer
6	4	1108183	Mach Bolt Socket Head Capscrew
7	4	F1900050	Washer Nord Lock
8	1	3101226	Mach Washer Motor Pinion
9	1	F0238100	Hex Head Capscrew $\frac{3}{8}$ - 16 x 1
10	1	6350027	Assy Swivel Manifold

PARTS

Rotation Drive System LXP 400/500

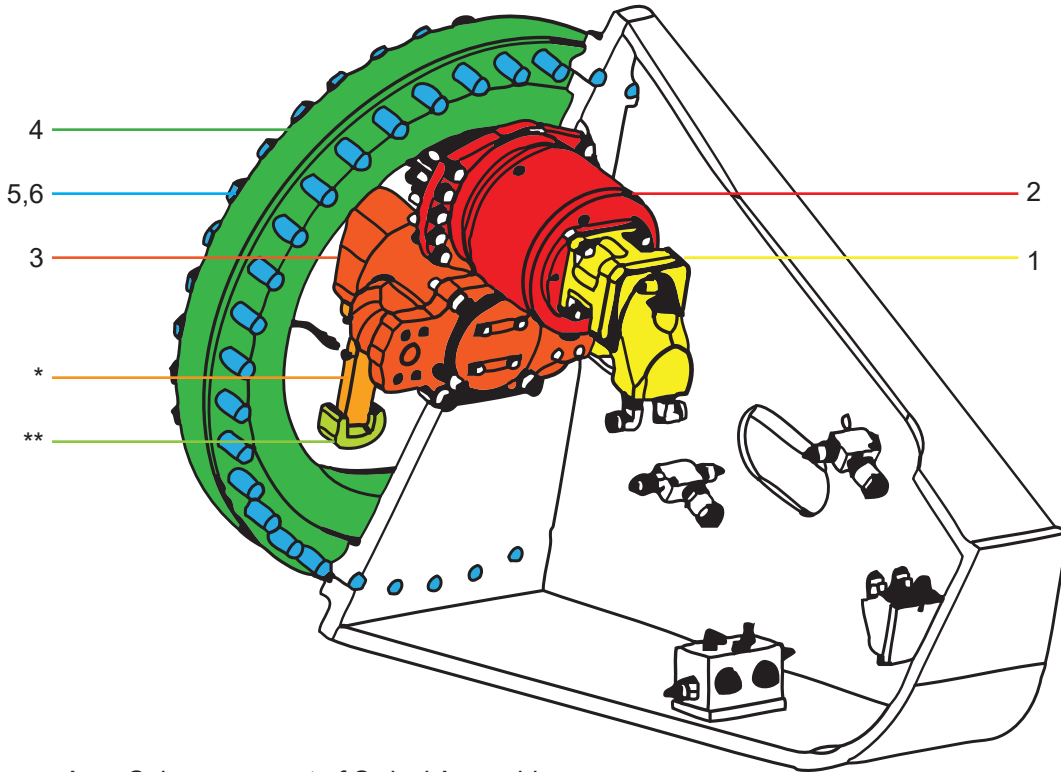

* Torque Arm, Sub-component of Swivel Assembly

** Torque Arm Stop, Sub-component of Swivel Assembly

Item	Part Number	Description
1	6300420	Motor
2	6300445	Gearbox
3	5410012	Swivel Assembly
4	6300429	Rotation Bearing
5	F0127130	Bolts M27 x 3 x 130 - 3 (qty 60)
6	F1202750	Washers

PARTS

Electrical

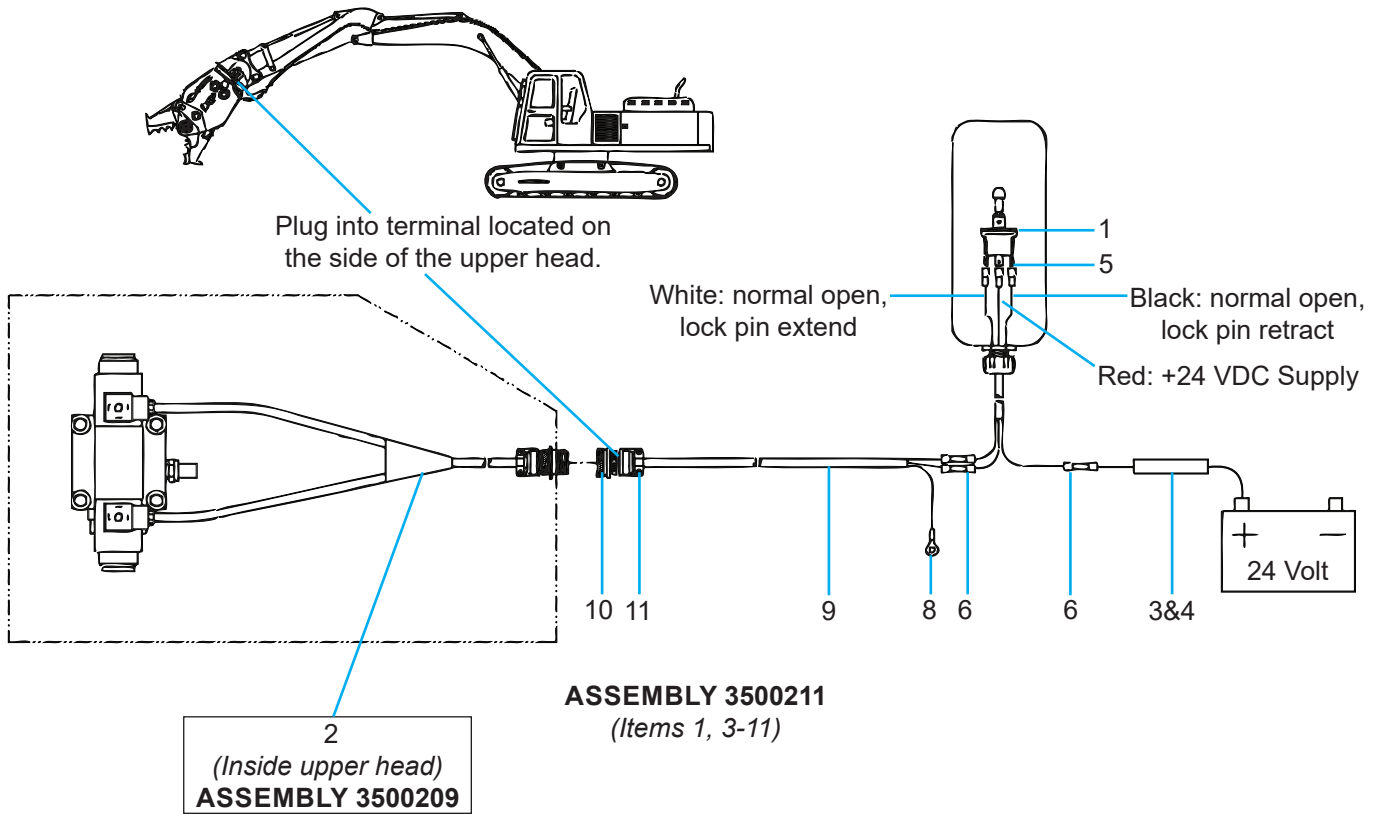

Item	Description	Part Number
1	Mount three-way locking toggle switch in excavator cab	3500211
2	Lock pin wiring harness sub-assembly	3500209
3	Fuse holder	Included in 3500211
4	Two-amp fuse	
5	Insulated connectors	
6	Butt connectors: white to white, black to black, red to fuse/battery	
7	Cable ties (not shown)	
8	Insulated ring terminal; green to ground	
9	Cable; use cable ties to secure along stick/boom	
10	Plug connector into terminal located on the side of the upper head	
11	Cable clamp	

TOOL LIST

The following is a list of tools available for purchase from Genesis. This list may not include every tool used for this attachment, such as those that would also commonly be used for maintaining an excavator.

Part Number	Description
6900001	Service tool kit - includes part numbers 6900002 through 6900020
6900002	1-1/2" 12-point socket, 1" drive
6900003	1-5/16" 12-point socket, 1" drive
6900004	5/8" impact hex bit socket, 3/4" drive
6900005	3/4" impact hex bit socket, 3/4" drive
6900006	3/4" drive female to 1" drive male adapter
6900007	1-1/4" combo wrench
6900008	Jet needle scaler
6900009	17mm socket, 3/4" drive, metric impact
6900010	Torque multiplier, 2000 ft/lb
6900011	3/4" drive torque wrench, 600 ft/lb
6900012	26" male/female ratchet, 1" drive
6900013	30" ratchet, 1" drive
6900014	5/16" LA hex key
6900015	1-5/16" combo wrench
6900016	7/8" combo wrench
6900017	1-1/8" combo wrench
6900018	40mm 6-point impact socket, 3/4" drive
6900019	46mm 6-point impact socket, 3/4" drive
6900020	Tool box
6900021	7/8" impact hex bit socket, 3/4" drive
6900022	1-1/2" 6-point socket, 1" drive
6900023	7/8" impact hex bit socket, 1" drive
6900024	36mm 6-point impact socket, 1" drive

BOLT TORQUE SPECIFICATIONS

Reference the product Thread Treatment Diagrams beginning on page 82 to determine whether to use wet or dry torque values for specific bolts.

Reference Procedures on page 84 for threadlocker or anti-seize application and bolt and bolt hole cleaning.

Prior to torquing, clean all bolt holes, bolts and nuts to remove dirt, grease and oil, and identify bolt type.

Never re-torque bolts that use Loctite. If a bolt becomes loose or damaged after the initial use when Loctite was applied and the bolt was torqued, the bolt must be replaced.

Never break tightened bolts loose with a torque wrench. Doing so may break the torque wrench or take it out of calibration.

Torque wrenches should be calibrated on an annual basis.

When using a torque multiplier with a torque wrench, incorrect settings will be multiplied by the ratio of the torque wrench.

Never use an impact driver on a torque multiplier.

THREAD TREATMENT DIAGRAM

Mobile Shears

Use this diagram to determine what thread treatment, if any, is required for each fastener.

For thread treatment application procedures, see page 84. For prescribed torque values, see page 86.

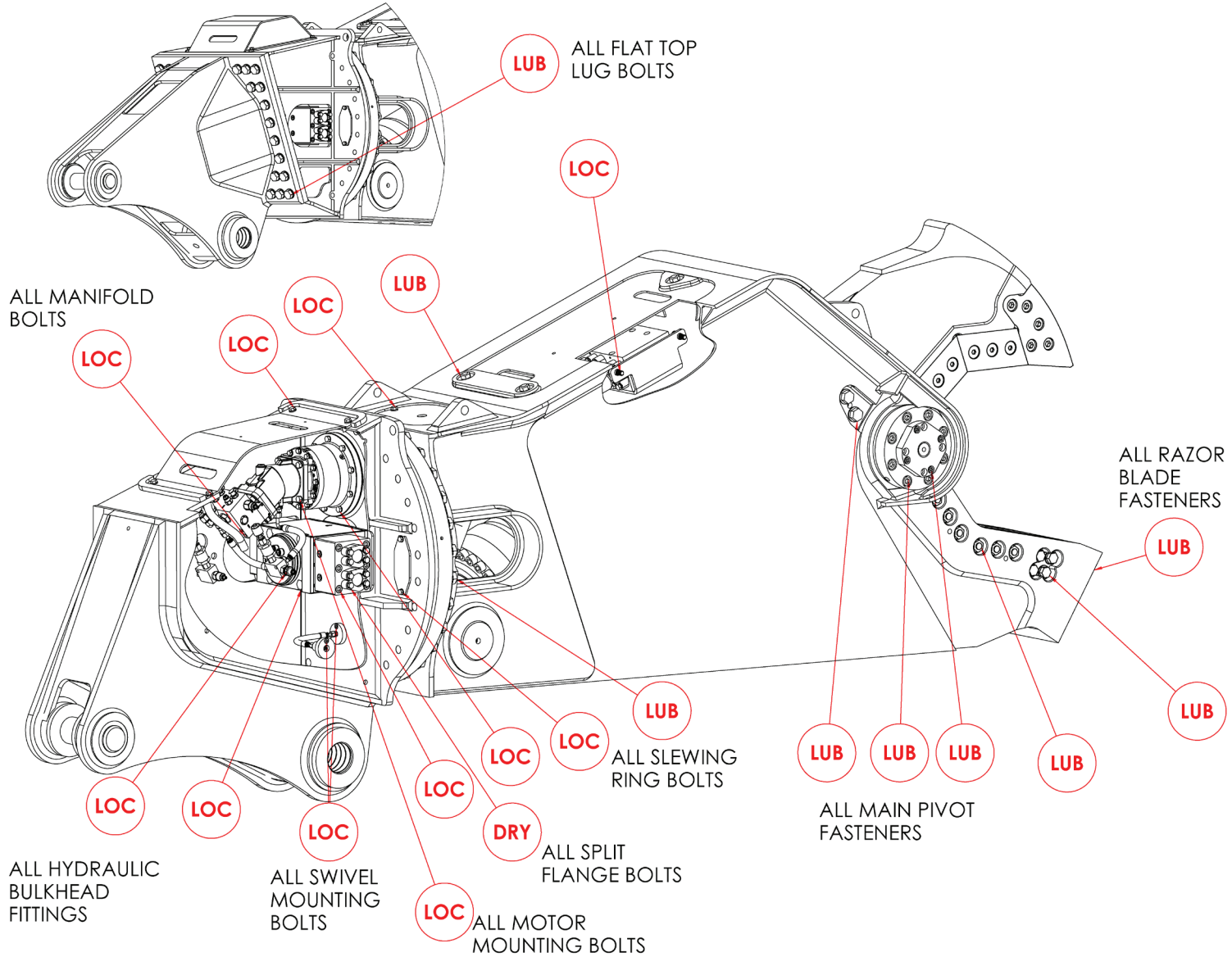

THREAD TREATMENT DIAGRAM

Processors

Use this diagram to determine what thread treatment, if any, is required for each fastener.

For thread treatment application procedures, see page 84. For prescribed torque values, see page 86.

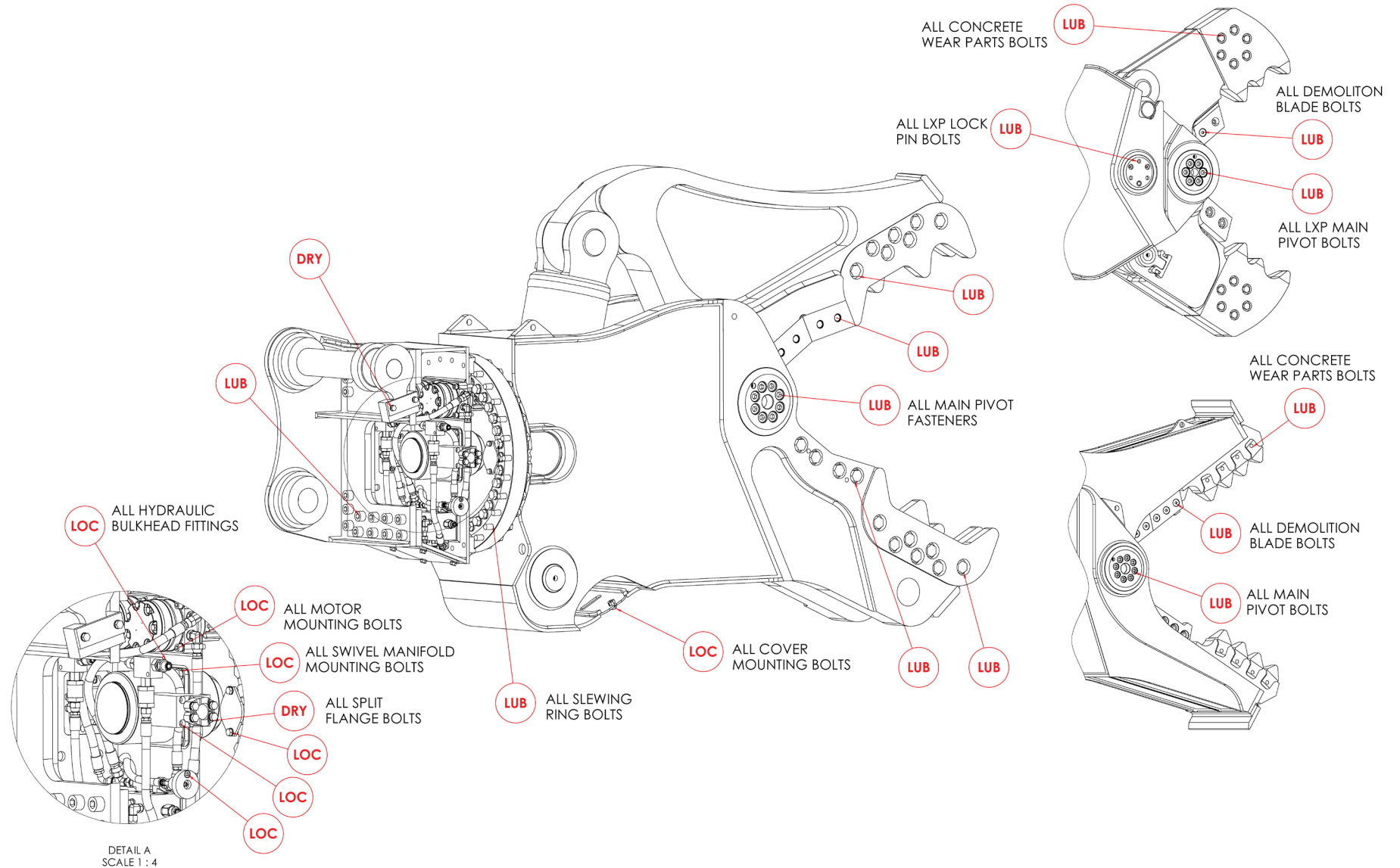

PROCEDURES

Reference the product Thread Treatment Diagrams beginning on page 82 to determine which of the following procedures is required.

Cleaning

To ensure proper performance of thread treatment and accurate torque values, clean and degrease **all internal and external threads** prior to application of threadlocker, anti-seize or primer and before installation of hardware.

- Ensure both internal and external threads are free of dirt or debris.
- Use brake cleaner or similar cleaning solvent on all threads to remove any grease or oil.
- Allow threads to dry.

NOTICE

Failure to properly clean threads will cause threadlocker, primer, and/or anti-seize to not properly cure!

LOC

Threadlocker

For bolted connections requiring threadlocker, use **Loctite 263** or equivalent applied using the following procedure:

- Clean and degrease all threads.
- For thru holes or nuts, apply threadlocker to bolt threads.
- For blind holes, apply stripe of threadlocker along the length of the hole (applying to the bolt can cause escaping air to remove threadlocker as the bolt is inserted).
- Torque bolt to specified **Wet Torque Value**, see page 86.

For threaded hydraulic fitting connections, use **Loctite 5452** or equivalent thread sealant in conjunction with **Loctite 7471** primer using the following procedure:

- Clean and degrease all threads.
- Apply Loctite 7471 primer to both external and internal threads and allow to dry.
- Apply threadlocker to 360 degrees of the threads on the male fitting, ensuring adequate coverage.
- Assemble fitting per directions in operator's manual.
- For O-ring boss and flat face O-ring connections, torque fittings to values specified on page 87.

Threadlocker

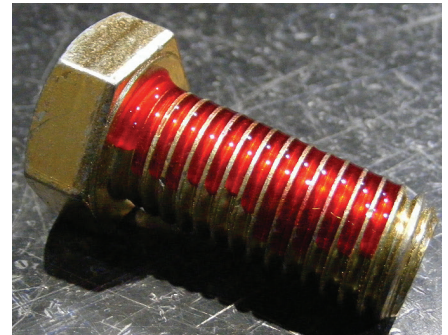

Blind Hole

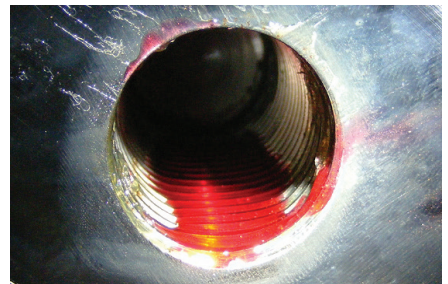

Hydraulic Fitting



PROCEDURES

LUB

Anti-Seize

For bolted connections requiring anti-seize lubrication, use **Loctite LB8008** or equivalent using the following procedure:

- Clean and degrease all threads.
- Apply thin coat of anti-seize to internal and external threads and under bolt head and/or nut, ensuring complete coverage.
- Torque bolt to specified **Wet Torque Value**, see page 86.

Anti-Seize









DRY

No Thread Treatment

- Clean and degrease all threads.
- Torque bolt to specified **Dry Torque Value**, see page 86.

BOLT TORQUE SPECIFICATIONS

Dry Torque Values					
		Hex/Socket Head		Flat Head	
		 			
Fastener Grade	Size x Pitch	Nm	Ft-lb	Nm	Ft-lb
CL 10.9	M8 x 1.25	35	26	27	20
	M10 x 1.50	71	53	58	42
	M12 x 1.75	124	92	101	73
	M14 x 1.50	200	148	163	118
	M14 x 2.00	200	148	163	118
	M16 x 2.00	311	230	254	184
	M20 x 1.50	610	450	498	360
	M20 x 2.50	608	449	497	359
	M24 x 3.00	1054	778	861	622
	M27 x 3.00	1543	1138	1260	910
	M30 x 3.50	2095	1545	1712	1236
	M36 x 4.00	3659	2699	2991	2159
8	1/4-20	14	11	11	8
	5/16-18	32	24	26	19
	3/8-16	59	44	48	35
	7/16-14	94	70	77	56
	1/2-13	143	106	116	84
	1/2-20	162	120	133	96
	5/8-11	287	212	234	169
	3/4-10	509	376	415	300
	7/8-9	821	606	670	484
	1.00-8	1232	909	1007	727
	1.00-14	1383	1020	1130	816
	1.25-7	2463	1817	2013	1453
L9	1.50-6	4287	3162	3504	2529

Wet Torque Values					
		Hex/Socket Head		Flat Head	
		 			
Fastener Grade	Size x Pitch	Nm	Ft-lb	Nm	Ft-lb
CL 10.9	M8 x 1.25	29	22	23	17
	M10 x 1.50	61	45	49	36
	M12 x 1.75	105	78	85	62
	M14 x 1.50	150	111	121	88
	M14 x 2.00	170	126	138	100
	M16 x 2.00	265	196	216	156
	M20 x 1.50	456	337	372	269
	M20 x 2.50	517	382	422	305
	M24 x 3.00	894	660	731	528
	M27 x 3.00	1312	968	1072	774
	M30 x 3.50	1779	1312	1453	1049
	M36 x 4.00	3110	2294	2542	1835
8	1/4-20	13	10	11	8
	5/16-18	27	20	22	16
	3/8-16	50	37	40	29
	7/16-14	80	59	65	47
	1/2-13	122	90	99	72
	1/2-20	138	102	112	81
	5/8-11	244	180	199	144
	3/4-10	433	320	354	256
	7/8-9	698	515	570	412
	1.00-8	1046	772	854	617
	1.00-14	1175	867	960	693
	1.25-7	2095	1545	1712	1236
L9	1.50-6	3644	2688	2979	2150

O-RING BOSS & FLAT FACE O-RING TORQUE SPECIFICATIONS

O-Ring Boss Torque Values		
Size Dash	Nm	Ft-lb
-4	22	16
-5	27	20
-6	36	26
-8	83	60
-10	110	80
-12	187	135
-14	249	180
-16	304	220
-20	387	280
-24	498	360

Flat Face O-Ring Torque Values		
Size Dash	Nm	Ft-lb
-4	18	13
-6	30	22
-8	60	44
-10	85	62
-12	121	88
-14	121	88
-16	160	116
-20	213	154
-24	274	198

BOLT DRIVE SPECIFICATIONS

Thread Size x Pitch	Hex Head	Socket Head	Flat Head
			
Wrench/Drive Size			
M8 x 1.25	13mm	6mm	5mm
M10 x 1.50	17mm	8mm	6mm
M12 x 1.75	19mm	10mm	8mm
M14 x 1.50	22mm	12mm	10mm
M14 x 2.00	22mm	12mm	10mm
M16 x 2.00	24mm	14mm	10mm
M20 x 1.50	30mm	17mm	12mm
M20 x 2.50	30mm	17mm	12mm
M24 x 3.00	36mm	19mm	14mm
M27 x 3.00	41mm	19mm	-
M30 x 3.50	46mm	22mm	-
M36 x 4.00	55mm	27mm	-
1/4-20	7/16"	3/16"	5/32"
5/16-18	1/2"	1/4"	3/16"
3/8-16	9/16"	5/16"	7/32"
7/16-14	5/8"	3/8"	1/4"
1/2-13	3/4"	3/8"	5/16"
1/2-20	3/4"	3/8"	5/16"
5/8-11	15/16"	1/2"	3/8"
3/4-10	1-1/8"	5/8"	1/2"
7/8-9	1-5/16"	3/4"	9/16"
1.00-8	1-1/2"	3/4"	5/8"
1.00-14	1-1/2"	3/4"	5/8"
1.25-7	1-7/8"	7/8"	7/8"
1.50-6	2-1/4"	1"	1"

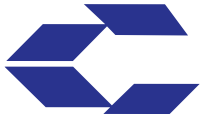

GENESIS®

The Promise of Performance.

CONTACT INFORMATION

Genesis Attachments

1000 Genesis Drive
Superior, WI 54880 USA

Toll Free: 888-SHEAR-IT
(888-743-2748)

Phone: 715.395.5252

E-mail:
info@genesisattachments.com

Europe/Africa/Middle East Genesis GmbH

Teramostrasse 23
87700 Memmingen, Germany

Phone: +49 83 31 9 25 98 0

Fax: +49 83 31 9 25 98 80
genesis-europe.com

E-mail:
info@genesis-europe.com

Asia Pacific Representative Office

24 Upper Serangoon View #12-28
Singapore 534205

Phone: +65 9673 9730

E-mail:
tchoo@genesisattachments.com

Central America & Colombia

Cra 13A #89-38 / Ofi 613
Bogota, Colombia

Phone: +57 1 610 8160 / 795 8747

E-mail:
contact@themsagroup.com

View and download all manuals: genesisattachments.com/manuals
Patents: genesisattachments.com/products/patents

Rev. Y - 5-3-24